



導電性高分子ハイブリッドアルミ電解コンデンサ
CONDUCTIVE POLYMER HYBRID ALUMINUM ELECTROLYTIC CAPACITORS

PEV/PZE

PEV / PZE シリーズ
SERIES

105°C 10,000時間品
105°C 10,000 hours

AEC-Q200

RoHS
Compliance



◆規格表 / SPECIFICATIONS

項目 Items	特性 Characteristics													
カテゴリ温度範囲 Category Temperature Range	-55 ~ +105°C													
定格電圧範囲 Rated Voltage Range	25 ~ 80Vdc													
静電容量許容差 Capacitance Tolerance	±20% (20°C, 120Hz)													
漏れ電流 Leakage Current (MAX)	I=0.01CV又は3μAのいずれか大なる値以下 (定格電圧印加2分後) I=0.01CV or 3μA whichever is greater. (After 2 minute) I=漏れ電流(μA) C=静電容量(μF) V=定格電圧(Vdc) I = Leakage Current C = Capacitance V = Rated Voltage													
損失角の正接 (tan δ) Dissipation Factor (MAX)	<table border="1"> <tr> <td>定格電圧(Vdc) Rated Voltage</td> <td>25</td> <td>35</td> <td>50</td> <td>63</td> <td>80</td> <td rowspan="2">(20°C, 120Hz)</td> </tr> <tr> <td>tan δ</td> <td>0.14</td> <td>0.12</td> <td>0.10</td> <td>0.09</td> <td>0.08</td> </tr> </table>	定格電圧(Vdc) Rated Voltage	25	35	50	63	80	(20°C, 120Hz)	tan δ	0.14	0.12	0.10	0.09	0.08
定格電圧(Vdc) Rated Voltage	25	35	50	63	80	(20°C, 120Hz)								
tan δ	0.14	0.12	0.10	0.09	0.08									
耐久 Endurance	105°C中で10000時間定格電圧(定格リップル重畳)印加後、下記の規格を満足すること。 After applying rated voltage with rated ripple current for 10000 hours at 105°C, the capacitors shall meet the following Criteria.													
高温高湿負荷 Biased Humidity	85°C、85% RH中で2000時間定格電圧印加後、下記の規格を満足すること。 After applying rated voltage for 2000 hours at 85°C and humidity of 85%, the capacitors shall meet the following Criteria.													
規格 Criteria	<table border="1"> <tr> <td>静電容量変化率 Capacitance Change</td> <td>初期値の ±30%以内 Within ±30% of the initial value.</td> </tr> <tr> <td>損失角の正接 Dissipation Factor</td> <td>規定値の 200%以下 Not more than 200% of the specified value.</td> </tr> <tr> <td>等価直列抵抗 ESR</td> <td>規格値の 200% 以下 Not more than 200% of the specified value.</td> </tr> <tr> <td>漏れ電流 Leakage Current</td> <td>規格値以下 Not more than the specified value.</td> </tr> </table>	静電容量変化率 Capacitance Change	初期値の ±30%以内 Within ±30% of the initial value.	損失角の正接 Dissipation Factor	規定値の 200%以下 Not more than 200% of the specified value.	等価直列抵抗 ESR	規格値の 200% 以下 Not more than 200% of the specified value.	漏れ電流 Leakage Current	規格値以下 Not more than the specified value.					
静電容量変化率 Capacitance Change	初期値の ±30%以内 Within ±30% of the initial value.													
損失角の正接 Dissipation Factor	規定値の 200%以下 Not more than 200% of the specified value.													
等価直列抵抗 ESR	規格値の 200% 以下 Not more than 200% of the specified value.													
漏れ電流 Leakage Current	規格値以下 Not more than the specified value.													
低温特性 Low Temperature Stability (インピーダンス比) Impedance Ratio (MAX)	$Z(-25^{\circ}\text{C}) / Z(+20^{\circ}\text{C}) \leq 1.5$ (100kHz) $Z(-55^{\circ}\text{C}) / Z(+20^{\circ}\text{C}) \leq 2.0$													

◆呼称方法 / PART NUMBER

$\square\square\square$ PEV/PZE $\square\square\square\square$ M $\square\square\square$ $\square\square$ $\phi D \times L$
 定格電圧 シリーズ名 静電容量 静電容量許容差 副記号 リード加工記号 ケースサイズ
 Rated Voltage Series Capacitance Capacitance Tolerance Option Lead Forming Case Size

◆リップル電流補正係数 /
MULTIPLIER FOR RIPPLE CURRENT

周波数 (Hz) Frequency	f	100 ≤ f < 1k	1k ≤ f < 10k	10k ≤ f < 20k
係数 Coefficient		0.05	0.30	0.70
周波数 (Hz) Frequency	f	20k ≤ f < 50k	50k ≤ f < 100k	100k ≤ f
係数 Coefficient		0.80	0.90	1.00

◆表示 / MARKING

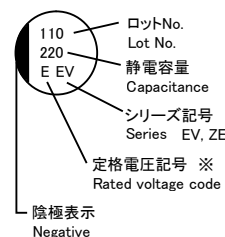

※電圧記号 Voltage Code

定格電圧 Rated Voltage (Vdc)	25	35	50	63	80
電圧記号 Voltage Code	E	V	H	J	K



導電性高分子ハイブリッドアルミ電解コンデンサ CONDUCTIVE POLYMER HYBRID ALUMINUM ELECTROLYTIC CAPACITORS

PEV/PZE

◆寸法図／DIMENSIONS

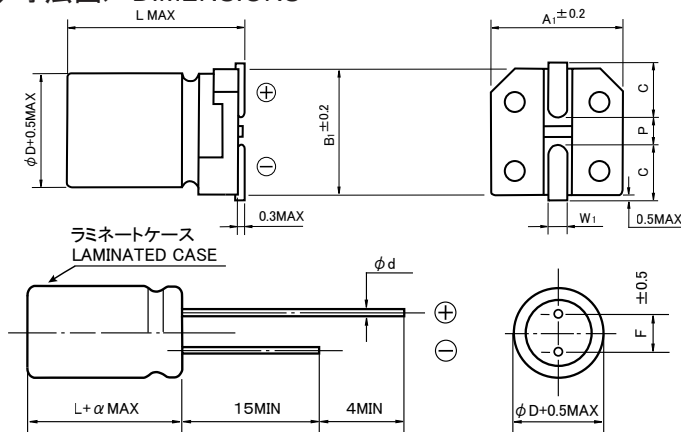

(mm)						
φD	L	A1	B1	C	W1	P
6.3	6.1	6.6	6.6	2.7	0.5~0.8	1.8
6.3	8	6.6	6.6	2.7	0.5~0.8	1.8
8	10.5	8.3	8.3	2.9	0.8~1.1	3.1
10	10.5	10.3	10.3	3.2	0.8~1.1	4.5

(mm)				
φD	L	F	φd	α
8	9	3.5	0.6	1.5
10	9	5.0	0.6	1.5

◆標準品一覧表／STANDARD SIZE

定格電圧 Rated Voltage (Vdc)	静電容量 Capacitance (μF)	外形寸法 Size φD X L (mm)		等価直列抵抗 ESR (mΩ MAX, 100kHz)		定格リップル電流 Rated Ripple Current (mA rms / 105°C, 100kHz)	許容リップル電流 Permissible Ripple Current (mA rms)	
		PEV series (SMD)	PZE series (Radial Lead type)	20°C	-40°C		105°C, 100kHz	100°C, 100kHz
25	56	6.3×6.1	—	50	—	1430	2240	2360
	100	6.3×8	—	30	—	2200	3460	3640
	220	8×10.5	8×9	27	—	2520	3970	4180
	330	10×10.5	10×9	20	—	2740	4320	4550
35	47	6.3×6.1	—	60	—	1430	2240	2360
	68	6.3×8	—	35	—	2200	3460	3640
	150	8×10.5	8×9	27	—	2520	3970	4180
	270	10×10.5	10×9	20	—	2740	4320	4550
50	22	6.3×6.1	—	80	—	1210	1900	2000
	33	6.3×8	—	40	—	1760	2760	2910
	68	8×10.5	8×9	30	—	1980	3110	3270
	100	10×10.5	10×9	28	—	2200	3460	3640
63	10	6.3×6.1	—	120	—	1100	1730	1820
	22	6.3×8	—	80	—	1650	2590	2730
	33	8×10.5	8×9	40	—	1870	2940	3090
	56	10×10.5	10×9	30	—	1980	3110	3270
80	22	8×10.5	8×9	45	—	1760	2760	2910
	27	8×10.5	8×9	45	—	1760	2760	2910
	39	10×10.5	10×9	35	—	1870	2940	3090
	47	10×10.5	10×9	35	—	1870	2940	3090

◆温度係数／TEMPERATURE COEFFICIENT FOR RIPPLE CURRENT

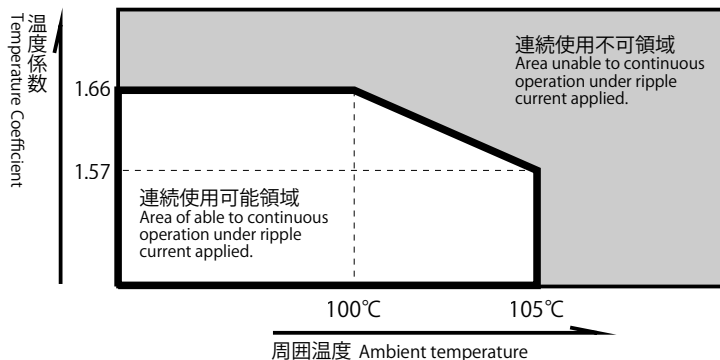

温度 Temperature T (°C)	T ≤ 100	105
係数 Coefficient (I _{MAX} /I ₀)	1.66	1.57

温度係数 I_{MAX}/I₀ : 定格リップル電流 (I₀) を超えて連続印加可能なリップル電流最大値 (I_{MAX}) を示す係数。寿命推定時間は寿命計算式に従う。

Temperature Coefficient I_{MAX}/I₀ : Coefficient indicating the maximum permissible ripple current (I_{MAX}) that can be continuously applied beyond the rated current (I₀). Estimated lifetime complies with our lifetime calculation formula.