

Capacitors Catalog

CHIP ALUMINUM ELECTROLYTIC CAPACITORS
RADIAL LEAD ALUMINUM ELECTROLYTIC CAPACITORS
SNAP-IN ALUMINUM ELECTROLYTIC CAPACITORS



◆品質マネジメントシステム認証取得 Quality Management System Certificates
アルミニウム電解コンデンサ/Aluminum Electrolytic Capacitors

対象工場 Factories	取得日 Date of Registration	認定名 Standard	認定番号 Certificate Number
ルビコン株式会社 本社工場,秋田事業所,福島事業所,ますみヶ丘事業所 Rubycon Corporation Main Factory,Akita Factory, Fukushima Factory,Masumi-ga-Oka Factory	2018/09/13	IATF16949:2016	JQA-AUO139-1
	2018/11/14	ISO9001:2015	JMI-0273
ルビコンインドネシア株式会社 P.T. Rubycon Indonesia	2018/06/25	ISO9001:2015	98-2-0799
	2018/07/13	IATF16949:2016	12 111 50347 TMS

◆環境マネジメントシステム認証取得 Environmental Management System Certificates
アルミニウム電解コンデンサ/Aluminum Electrolytic Capacitors

対象工場 Factories	取得日 Date of Registration	認定名 Standard	認定番号 Certificate Number
ルビコン株式会社 本社工場,秋田事業所,福島事業所,ますみヶ丘事業所 Rubycon Corporation Main Factory,Akita Factory, Fukushima Factory,Masumi-ga-Oka Factory	2017/10/08	ISO 14001 :2015	JQA-EM0540
ルビコンインドネシア株式会社 P.T. Rubycon Indonesia	2018/04/02	ISO 14001 :2015	99-0055

◆RoHS規制物質への対応/Conforming to RoHS Directive

品種 TYPE	アルミニウム電解コンデンサ Aluminum Electrolytic Capacitors		
	チップタイプ SMD	リード線タイプ Lead Wire	スナップイン Snap-in
RoHS 指令 RoHS Compliance	対応済/Complied		
鉛 Lead	含有せず/ Not contain		
端子材質 Terminal material	(~φ10) Fe/Cu/Sn-0.5Bi (φ12.5~) Fe/Cu/Sn	Fe/Cu/Sn	
はんだ耐熱性 Resistance to Soldering heat	「リフロー許容条件」を参照ください。 Please find "Reflow Soldering Condition"		フローはんだ付け260°C 260°C Flow Soldering
カドミウム Cadmium	含有せず / Not contain		
水銀 Mercury	含有せず / Not contain		
六価クロム Chrome(VI)	含有せず / Not contain		
PBB PBDE	含有せず / Not contain		
DEHP, BBP DBP, DIBP	含有せず / Not contain		
RoHS 対応品識別 Identification for RoHS Compliance Parts	内装・外装ラベルに RoHS Compliance を表記 Add "RoHS Compliance" marking on inner and outer carton lable		

欧州REACH規則への適合について/Regarding compliance to European REACH Regulation

RIP3.8TGD(Technical Guidance Document: 2008/5/26 公開)の内容に基づき、弊社製電子部品は「意図的放出のない成形物」であり、欧州REACH規則第7条1項「登録」の適用外です。

According to the content of RIP3.8TGD(Technical Guidance Document) which is published on 26 May 2008, our electronic components are "articles without any intended release." Therefore the are not applicable for "Registration"for European REACH Regulation Article 7(1).

◆チップ形アルミニウム電解コンデンサ/CHIP ALUMINUM ELECTROLYTIC CAPACITORS

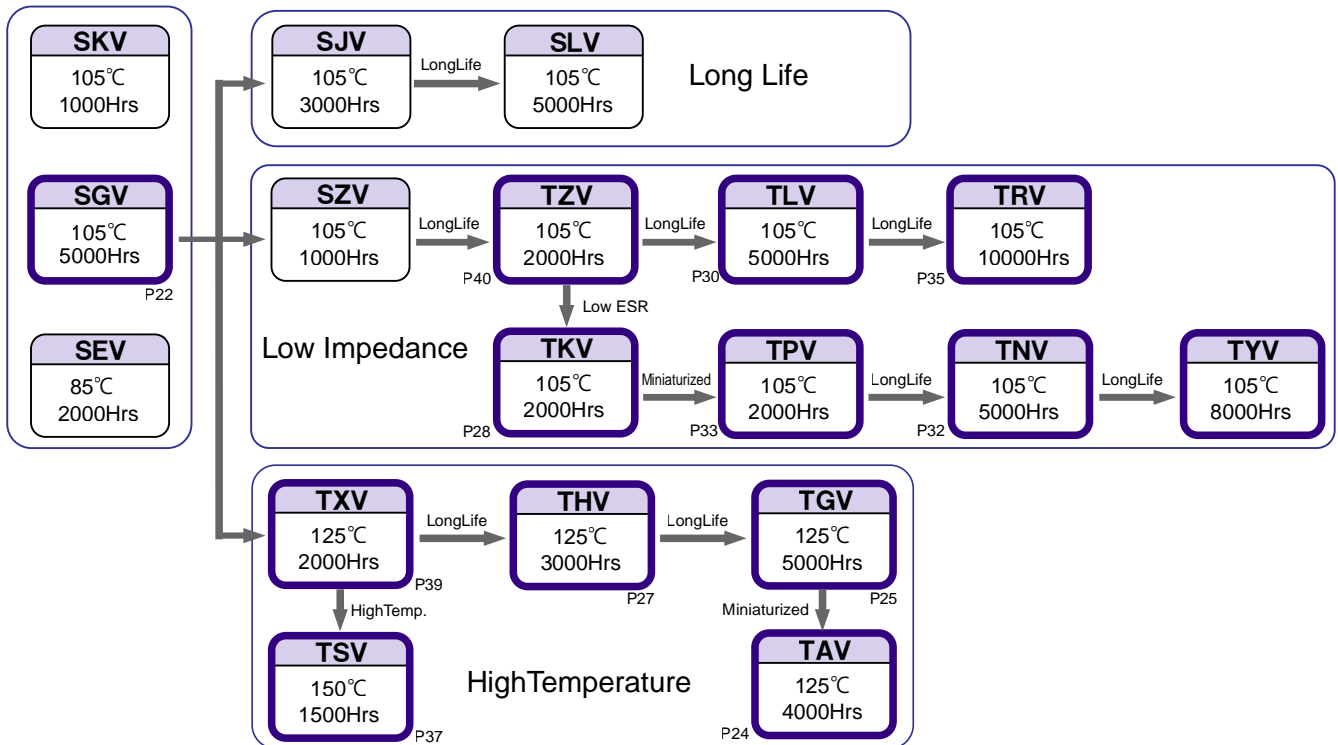

◆リード線形アルミニウム電解コンデンサ/RADIAL LEAD ALUMINUM ELECTROLYTIC CAPACITORS

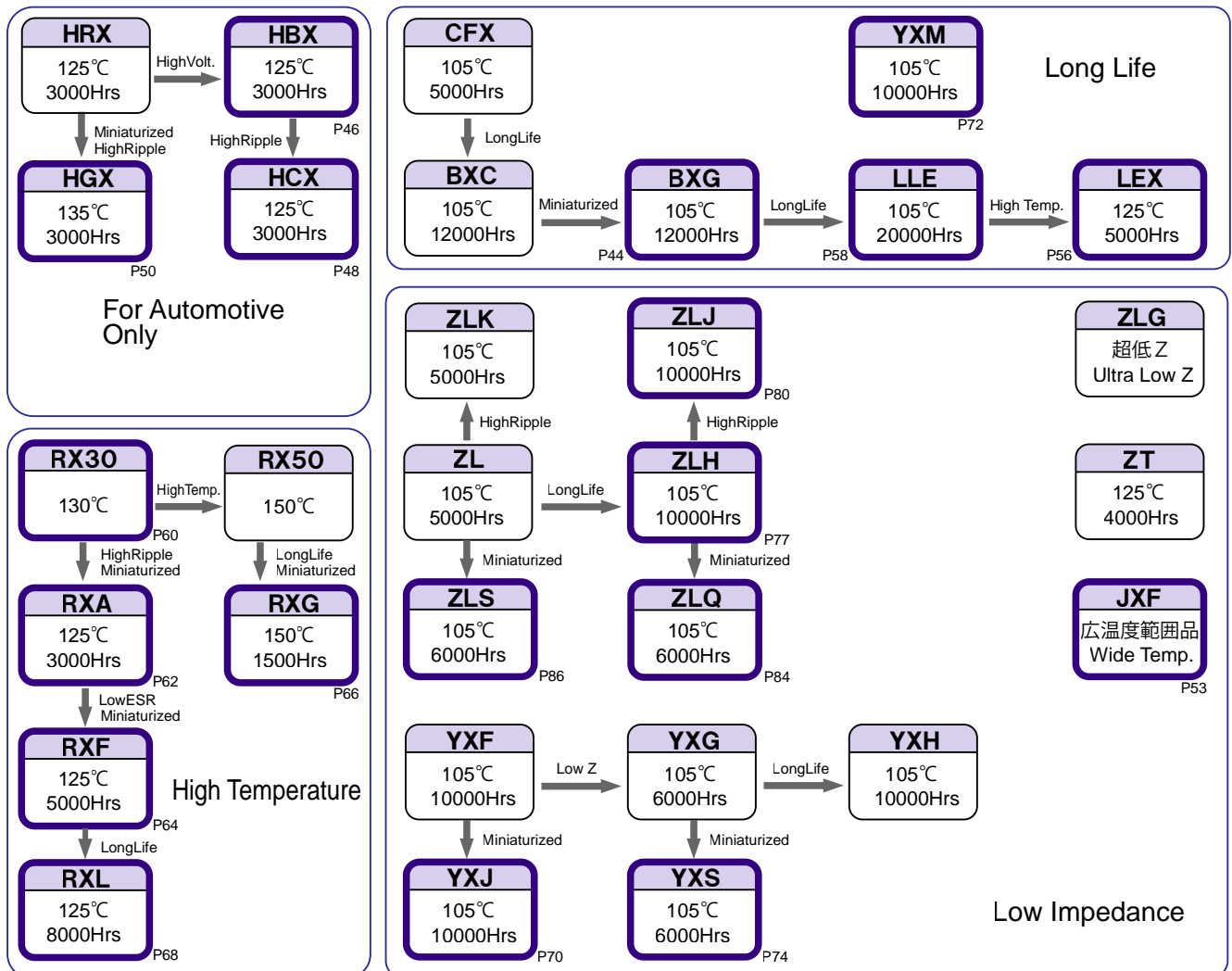

◆リード線形アルミニウム電解コンデンサ/RADIAL LEAD ALUMINUM ELECTROLYTIC CAPACITORS

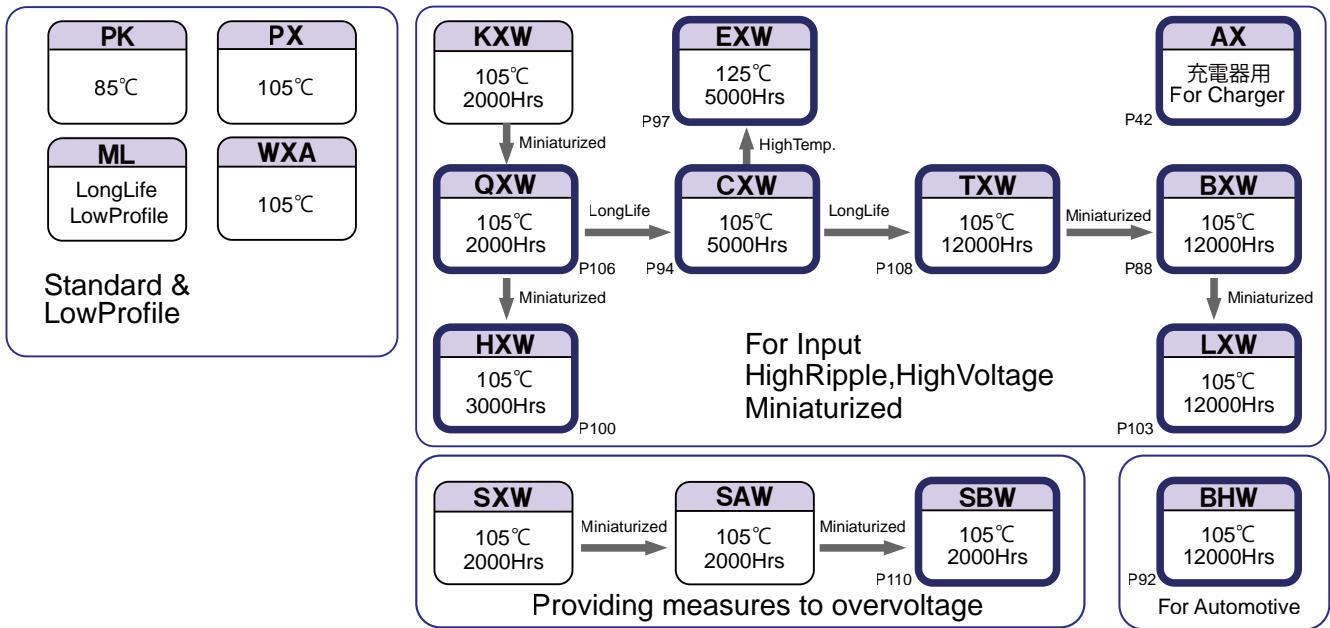

◆基板自立形アルミニウム電解コンデンサ/SNAP-IN ALUMINUM ELECTROLYTIC CAPACITORS

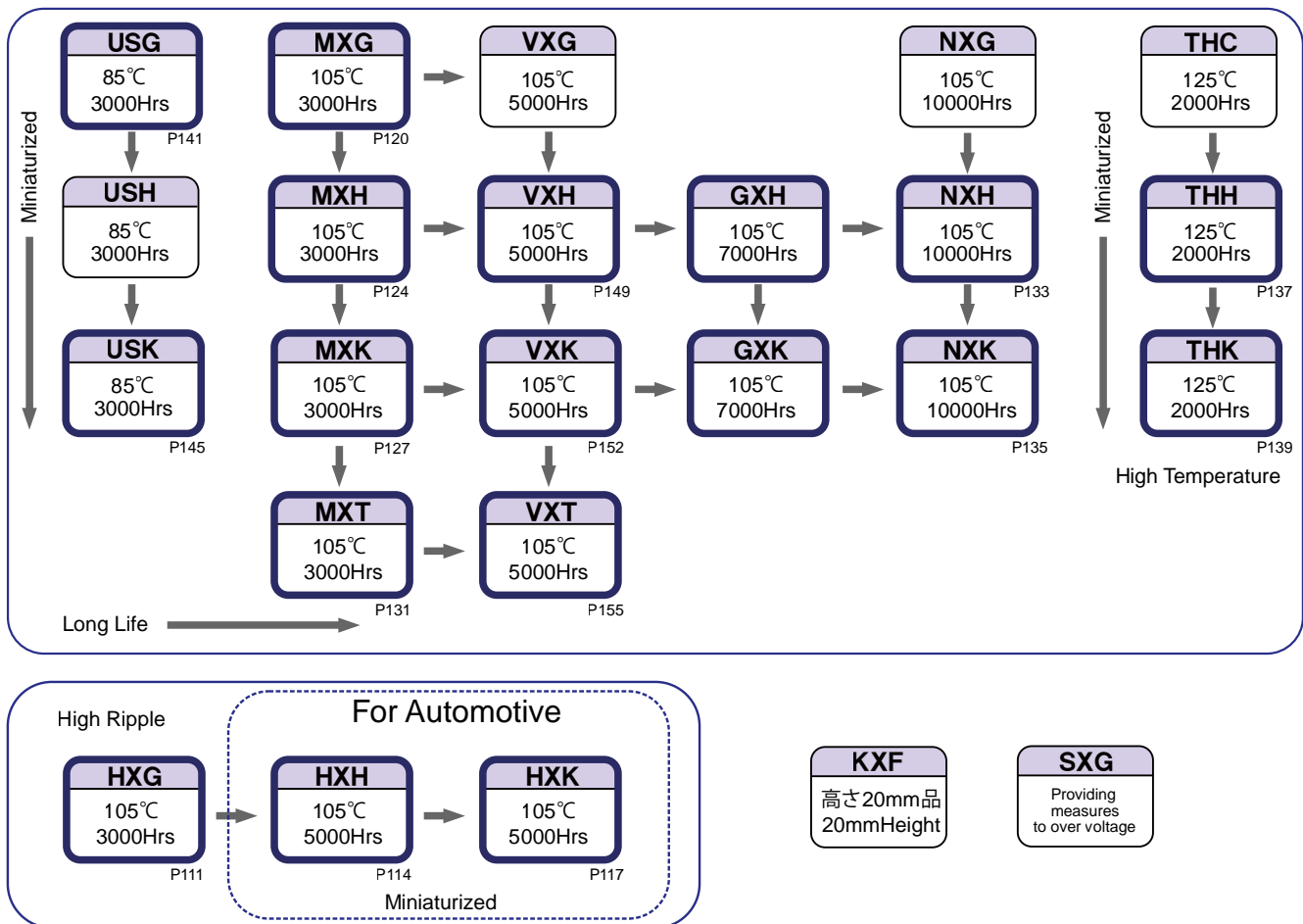

◆ストロボフラッシュ用アルミニウム電解コンデンサ/PHOTO FLASH ALUMINUM ELECTROLYTIC CAPACITORS

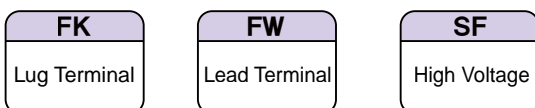

アルミニウム電解コンデンサの使用上の注意事項

アルミニウム電解コンデンサのご使用に際しては下記の点にご留意頂くようお願い致します。

アルミニウム電解コンデンサに次に示すような負荷を印加すると、急激な特性劣化が起こります。

- ・逆電圧
- ・定格電圧を超える過電圧
- ・定格リップル電流を超える過電流
- ・急激な充放電

この時、急激な発熱やガス発生が起こり、コンデンサ封口部からの電解液漏れや内圧の上昇による圧力弁の作動に至ります。

条件によっては、コンデンサの破壊とともに可燃物(アルミニウム電解コンデンサに使用している電解液、電解紙は可燃物です)が外部へ飛散したり、発火する場合があります。

1. 回路設計での注意事項

- 1) 使用環境、取付け環境及び定格性能の確認
 - ・使用環境及び取付け環境が、コンデンサのカタログ又は納入仕様書に規定した定格性能の範囲内である事を確認し、使用してください。
- 2) 使用温度・リップル電流及び寿命
 - ・使用温度及び印加リップル電流は、カタログ又は納入仕様書に規定の範囲内としてください。
 - ① 高温度(カテゴリ上限温度を超える温度)で使用しないでください。
 - ② 過電流(定格リップル電流を超える電流)を流さないでください。
直流電圧とリップル電圧尖頭値の和が定格電圧を越えないように、かつ逆電圧とならないようにしてください。
 - ・コンデンサを2ヶ以上並列に接続する場合は、電流バランスを考慮してください。
 - ・アルミ電解コンデンサ端子間のリップル電圧の変動幅が大きい場合は、急激な充放電と同様な使用となります。リップル電圧の変動幅が70V_{p-p}を越える場合はご相談ください。
 - ・コンデンサの寿命は加速試験結果を基にした寿命推定式により求める事ができますが、この推定式による寿命時間には誤差が含まれており、保証値ではありません。この式により求められた結果が機器の寿命に対して十分に余裕を持ったコンデンサを選定してください。寿命推定式については弊社ホームページをご参照頂くか、弊社までお問い合わせください。

CAUTIONS FOR PROPER USE OF ALUMINUM ELECTROLYTIC CAPACITOR

To use Aluminum Electrolytic Capacitors properly, please pay attention to the points listed below.

When the following types of electrical loads indicated below are applied to Aluminum Electrolytic Capacitors, rapid deterioration of electrical property occurs :

- reverse voltage
- voltage beyond rated voltage
- ripple current beyond rated value
- severe charging/discharging

At such times, capacitors are heated very much together with gas evolution, so as to allow electrolyte leakage from sealing or to increase internal pressure enough to operate safety vent.

In some condition, capacitors may catch fire or explode to release combustibles (e.g. electrolyte, separator paper).

1. Cautions on Circuit Design

- 1) Operational Environment, Mounting Environment
 - Ensure that operational and mounting conditions are satisfied with the specified conditions detailed in the catalog and specification sheets.
- 2) Operating Temperature, Ripple Current and Load Life
 - Operating temperature and applied ripple current should be within the values specified in the catalog or specification sheets.
 - ① Do not use Aluminum Electrolytic Capacitors at a temperature exceeding the specified maximum category temperature.
 - ② Do not apply excessive current exceeding the specified rated ripple current.
 - The combined value of DC voltage and the peak of AC voltage must not exceed the rated voltage. Voltage application in the reverse direction is unallowable.
 - Consider current balance to connect 2 or more Aluminum Electrolytic Capacitors in parallel.
 - Application of ripple voltage with wide amplitude is equivalent to quick charge-discharge operation.
If ripple voltage with the amplitude over 70V_{p-p} is expected, please contact us.
 - Expected life of capacitor calculated with "life estimation equation" based on acceleration test results aren't guaranteed, since errors and variations are included.
We recommend to select a capacitor considering appropriate safety factor to the expected life. Please refer to our web-site or consult us for the detail of "life estimation equation".

3) 極性

- ・コンデンサは、有極性です。逆電圧又は交流電圧は、印加しないでください。極性が反転する回路には、両極性コンデンサをお選びください。ただし、両極性コンデンサも交流回路には使用できません。
- ・極性は下記(1)~(5)の通り表示してあります。
 - (1)本体側面に、帯又は矢印で陰極(マイナス)側端子を示しています。
 - (2)リード線端子同一方向形アルミニウム電解コンデンサは、リード線加工していない場合、リード線端子の短い方が陰極(マイナス)です。
 - (3)ケース天面に捺印表示しているアルミニウム電解コンデンサは、[◐]状または[◑]状の捺印のある方が陰極(マイナス)です。
 - (4)基板自立形(スナップインタイプ)あるいはラグ端子形アルミニウム電解コンデンサは、リベットに[⊗]の刻印がある方が陰極(マイナス)です。
 - (5)ネジ端子形アルミニウム電解コンデンサは、封口板に極性(+,-)が表示されています。

4) 充放電

- ・コンデンサは、急激な充放電が繰り返される回路に使用しないでください。急激な充放電が繰り返される回路に使用されるコンデンサについては、ご相談ください。

5) 印加電圧

- ・コンデンサに過電圧(定格電圧を超えた電圧)を印加しないでください。
- ・コンデンサを2ヶ以上直列に接続する場合は、電圧バランスを考慮してコンデンサと並列に分圧抵抗器を挿入してください。

6) コンデンサの絶縁

- ・コンデンサは、次の間で回路的に完全に隔離してください。
 - ①ケースと陰極端子及び陽極端子並びに回路パターン間
 - ②自立形の無接続(強度補強用)端子と他の陽極端子及び陰極端子並びに回路パターン間
- ・コンデンサの外装スリーブは、絶縁が保証されていません。絶縁機能が必要な箇所には、使用しないでください。スリーブに絶縁機能が必要な場合は、ご相談ください。

7) 使用環境の制限

- ・コンデンサは次の環境では、使用しないでください。
 - ①直接水、塩水及び油がかかったり、又は結露状態になる環境
 - ②有害ガス(硫化水素、亜硫酸、亜硝酸、塩素、アンモニア、臭素、臭化メチルなど)が充満する環境
 - ③直射日光、オゾン、紫外線及び放射線が照射される環境
 - ④酸性及びアルカリ性溶剤がかかる環境
 - ⑤振動又は衝撃条件がカタログ又は納入仕様書の規定範囲を超える過激な環境

3) Polarity

- ・Do not apply reverse voltage or AC voltage to Aluminum Electrolytic Capacitors, since they are normally polarized. Please use non-polar type capacitors to a circuit with polarity alteration. Note that such non-polar type cannot be used for AC circuit.
- ・Polarity is indicated as follows:
 - (1)Negative terminal is indicated with color band or arrows on capacitor body.
 - (2)On radial leaded Aluminum Electrolytic Capacitors with straight radial leads, the shorter radial lead is the negative terminal.
 - (3)On capacitors with mark on top of aluminum can, the terminal with the mark[◐] or[◑] is negative.
 - (4)On Snap-In and Lug Terminal type capacitors, the knurled rivet[⊗] indicates the negative terminal.
 - (5)On Screw Terminal type capacitors, polarity mark (+,-) indicates on terminal plate.

4) Charging and Discharging

- ・Do not use Standard Aluminum Electrolytic Capacitors to applications with rapid charge and discharge cycles. Consult us about capacitors specially designed for rapid charge-discharge cycles.

5) Applied Voltage

- ・Do not apply voltage beyond the rated voltage to capacitors.
- ・Use bleeder resistors to a circuit using 2 or more Aluminum Electrolytic Capacitors in series. In this case, the resistors should be connected parallel to the capacitors.

6) Insulation

- ・Electrically isolate Aluminum Electrolytic Capacitors as follows:
 - ①Among aluminum can, negative terminal, positive terminal and circuit pattern.
 - ②Among auxiliary terminals on snap-in type, positive terminal,negative terminal and circuit pattern.
- ・The sleeve of Aluminum Electrolytic Capacitor is not recognized as an insulator, so that standard capacitors should not be used to a circuit requiring electric insulation. Please consult us for capacitors with insulating sleeve.

7) Use Conditions

- ・Be sure to keep Aluminum Electrolytic Capacitors from the following environments:
 - ①Damp atmosphere where spray of water, saltwater or oil is expected, or where condensation may occur.
 - ②Atmosphere including hazardous gas/fumes such as hydrogen sulfide, sulfurous acid, nitrous acid, chlorine, ammonia or bromine.
 - ③Exposure to direct sunshine, ozone, ultraviolet rays or radiation.
 - ④Exposure to acid or alkaline solution.
 - ⑤Severe vibration or shock beyond the condition specified in the catalog or specification sheets.

8) プリント配線板の設計

・コンデンサをプリント配線板に配置する/位置決めするとき、次の内容を確認の上、設計してください。

- ①コンデンサの端子間隔にプリント配線板の穴間隔を合わせてください。
- ②コンデンサの圧力弁部の上に配線や回路パターンが来ないように設計してください。
圧力弁付きアルミニウム電解コンデンサは、逆電圧や過電圧が印加された時、又カタログ等で規定する許容値を越えたりブル電流が流れた時等の異常時に、圧力弁が作動して電解液を含む高温のガスを逃すように設計されています。
- (1)ケース圧力弁は、作動時に弁部分が膨らみます。基板取付け時はセットの上蓋等と接触しないように下表に示すような空隙を設けてください。空隙がないと圧力弁が作動しなくなります。

ケース外径	空隙
φ 6.3~16mm	2mm MIN.
φ 18~35mm	3mm MIN.
φ 40mm~	5mm MIN.

- (2)プリント配線板側にコンデンサの圧力弁が付く場合は、圧力弁の位置に合わせて圧力弁作動時のガス抜き穴を開けてください。
- (3)ネジ端子形コンデンサの封口部は、下向きにしないでください。また、横に寝かせる場合には、陽極端子を上にしてください。
- ③コンデンサの封口部の下には、回路パターンを配線しないでください。
電解液は導電性を有しており、万一漏れ出た電解液がプリント基板上に付着すると、パターンを腐食させたりパターン間のトラッキングやショートにより発煙、発火に至る場合があります。
- ④コンデンサの周辺及びプリント配線板の裏側(コンデンサの下)への発熱部品の配置は避けてください。
- ⑤チップコンデンサ用プリント配線板のランドパターンは、カタログ又は納入仕様書の規定によって回路設計してください。

9) コンデンサの短時間漏れ電流

・コンデンサに直流電圧を印加すると漏れ電流が流れますが、アルミ電解コンデンサは他のコンデンサに比べて漏れ電流が大きく、温度、印加電圧、印加時間によって漏れ電流が変化します。特に、2分値等の規定時間に達しない短時間の漏れ電流値は変動が大きくなります。従って機器の制御や判定などの時定数回路を含む用途に使用される場合、理論的に得られる値と大きく異なる為、注意が必要です。
このような回路で使用される場合には、機器の要求精度に対して十分余裕を持ったコンデンサを選定してください。

10) その他

- ・温度及び周波数の変動によって、コンデンサの電気的な特性は変化します。この変化分を考慮の上、回路設計してください。
- ・両面のプリント配線板にコンデンサを取り付けるとき、コンデンサの下に余分なプリント配線板穴及び表裏接続用貫通穴がないように回路設計してください。
- ・安全性が求められる電子機器へのご使用に際しては、電解コンデンサの故障モードを考慮し、設計面からの安全性確保を行ってください。
 - ①保護回路、保護装置によるシステムの安全化
 - ②冗長回路などによるシステムの安全化
- ・ストロボフラッシュ用アルミニウム電解コンデンサは、写真撮影用ストロボフラッシュ(エレクトロニックフラッシュ)のメインコンデンサ以外の用途には使用できません。

8) Consideration for Circuit Design

・In designing a printed circuit board (PCB) with Aluminum Electrolytic Capacitors, the following matters should be ensured:

- ①Alignment of through-hole pitch on the circuit with radial lead pitch of each capacitor.
- ②Avoid wiring or circuit pattern around the capacitor's pressure relief vent.
The vent is designed to operate to release excessive hot gas including electrolyte, in case of reverse voltage or excessive voltage, or if ripple current exceeding the permissible value is applied.

- (1)The pressure relief vent bulges right before operation. Ensure enough space shown below above the vent of each capacitor, so as to prevent the capacitor from touching the cover of the set. The pressure relief vent will not open without appropriate space.

Body Dia.	Space
φ 6.3—16mm	2mm MIN.
φ 18—35mm	3mm MIN.
φ 40mm—	5mm MIN.

- (2)In case capacitor's vent is facing the surface of PCB, make a gas release hole on the board.
- (3)Screw terminal capacitor should not be mounted sealing end down on PCB. To mount the capacitor sideways, positive terminal must be on the upper side.
- ③Do not lay copper lines or circuit patterns under capacitors. Electrolyte is electrically conductive. In case of deposition of electrolyte on the surface of PCB, corrosion of circuit pattern, or tracking or short circuit between patterns may occur to generate smoke or fire at worst.
- ④Avoid heating parts mounting around Aluminum Electrolytic Capacitors or backside of PCB.
- ⑤Land patterns for chip capacitor should comply with the catalog or specification sheets.

9) Short time leakage current

・The leakage current of aluminum electrolytic capacitor is rather larger than other types of capacitor. This value will be influenced by temperature, applied voltage and applying time of voltage.
Particularly, brief leakage current level which does not reach to specified time such as 2 minutes after applied voltage is unstable. Therefore, please pay attentions when aluminum capacitors are used for application such as timing circuit which include time constant circuit because actual leakage current level is different with simple calculation of "CR circuit". If it is used in such a circuit, please select a capacitor with a margin for the required accuracy of the instrument.

10) Others

- ・Consider this variation of electric characteristics of Aluminum Electrolytic Capacitor to design circuits. The characteristics vary with operating temperature and frequency.
- ・Extra through-holes should be avoided around or under Aluminum Electrolytic Capacitors on double sided or multilayer PCB.
- ・On use of Aluminum Electrolytic Capacitors to electronic equipment requiring higher safety, consider failure mode of the capacitor to ensure safety at design stage.
 - ①System safety with circuit protection and protective devices.
 - ②System safety with redundant circuits, etc.
- ・Rubycon Photo Flash Capacitors are designed, manufactured and intended solely for use in photo flash and other photographic equipment.

2. 取り付け時の注意事項

1) 取り付け前の予備知識

- ・セットに組み込んで通電したコンデンサは、再使用しないでください。定期点検時の電気的性能を測定するために取り外したコンデンサを除いて、再使用はできません。
- ・コンデンサには、再起電圧が発生する場合があります。このとき、約1kΩの抵抗器を通して放電してください。
- ・長期保管のコンデンサは、漏れ電流が増大している場合があります。このとき、長時間放置された製品には、以下に示す方法で電圧処理を実施してください。

電圧処理

コンデンサに約1kΩの保護抵抗器を直列に接続し、定格電圧に等しい直流電圧を1時間印加し、次に約1Ω/Vの抵抗器を通して放電する。

2) 取り付け時

- ・コンデンサの定格(静電容量及び電圧)を確認してから、取り付けてください。
- ・コンデンサの極性を確認してから取り付けてください。
- ・コンデンサは床などに落下させないでください。このとき、落下したコンデンサは、使用しないでください。
- ・コンデンサを変形させて取り付けしないでください。
- ・コンデンサの端子間隔とプリント配線板穴間隔とが合っていることを確認してから取り付けてください。
- ・基板自立形(スナップイン形)コンデンサは、その基板に密着する(浮いた状態にない)まで押し込んで取り付けてください。
- ・自動挿入機によってコンデンサのリード線をクリンチ固定する強さは、強すぎないようにしてください。
- ・自動挿入機及び装着機の吸着具、製品チェッカー及びセンタリング操作による衝撃力に注意してください。
- ・セットにおける振動・衝撃等が懸念される場合はコンデンサをプリント基板に取付ける際、補助具・接着剤で補強してください。
- ・ネジ端子の締めつけトルクは、カタログ又は納入仕様書で規定された範囲内としてください。

3-1) はんだごてによるはんだ付け

- ・はんだ付け条件(温度、時間)は、納入仕様書に規定の範囲内としてください。
- ・端子間隔とプリント配線板穴間隔が不整合のため、リード線端子を加工する必要がある場合には、はんだ付けする前に、コンデンサ本体にストレスがかからないように加工してください。
- ・はんだごてによる手直しをするとき、一度はんだ付けしたコンデンサを取り外す必要がある場合には、コンデンサの端子にストレスがかからないように、はんだが十分溶融してから行ってください。
- ・はんだごての先がコンデンサの本体に触れないようにしてください。

3-2) フローはんだ付け

- ・コンデンサの本体を溶融はんだの中に浸せきしてはんだ付けしないでください。プリント配線板を介在させて、コンデンサのある反対側の裏面のみにはんだ付けしてください。
- ・はんだ付け条件(予備加熱、はんだ付け温度、端子浸せき時間)は、納入仕様書に規定の範囲内としてください。
- ・端子部以外にフラックスが付着しないようにしてください。
- ・はんだ付けのとき、他の部品が倒れてコンデンサに接触しないようにしてください。

2. Cautions for Assembly

1) Precautions for assembly

- ・Do not reuse Aluminum Electrolytic Capacitors once mounted and electrified in a unit. Reuse of the capacitors is unallowable unless they are detached from PCB for the purpose of electric measurement.
- ・Aluminum Electrolytic Capacitors may have recurring voltage even after discharging. Please discharge capacitors through a 1kΩ resistor before use.
- ・Leakage current of Aluminum Electrolytic Capacitors may be increased after storage for a long time. Conduct electrification treatment for such capacitors before use.

Electrification Treatment

Connect a 1kΩ resistor in series with the subject capacitor, and apply the DC voltage as high as the Rated Voltage for 1 hour. Discharge the capacitor through a resistor of about 1Ω/Volt after the electrification.

2) Assembly Process

- ・Ensure polarity of each capacitor before mounting.
- ・Keep capacitors from falling onto the floor. Do not use capacitors if they are fallen onto a hard surface.
- ・Do not deform capacitors.
- ・Ensure that terminal pitch of each capacitor is aligned with through-hole pitch on PCB.
- ・For snap-in capacitors, press them to stick firmly with PCB. Lift of capacitors is unacceptable.
- ・Avoid excessive force to clinch lead wires in auto-insertion process.
- ・Avoid excessive shock to capacitors on automatic insertion machine, during mounting, parts inspection or centering operations.
- ・Please use supporting materials such as fixture or adhesive to mount capacitors to PCB, in case vibration or shock is expected.
- ・Use the value of torque within the range described in the catalog or specification sheets to tighten screw terminals.

3-1) Soldering

- ・Soldering should be performed with the conditions (temperatures, times) specified in the specification sheets.
- ・In case of requirement of lead wire reforming due to terminal pitch unaligned with through-hole pitch on PCB, capacitors should be kept from stress on body.
- ・In case that capacitor is required to detach from PCB due to hand rework, the detachment should be made after solder is fully melted, so as to keep the capacitor from stress on radial leads.
- ・Do not touch soldering iron with capacitor body.

3-2) Flow Soldering

- ・Do not dip capacitor body into solder bath. Dip only the opposite side of PCB.
- ・Soldering conditions (preheat, soldering temperature, dipping time) should conform to the specification sheets.
- ・Be sure to apply soldering flux only to capacitor terminals.
- ・Be careful that another part doesn't fall in soldering to touch capacitors.

3-3) リフローはんだ付け

- ・はんだ付け条件(予備加熱、はんだ温度、時間、リフロー回数)は、カタログ又は納入仕様書に規定の範囲内としてください。
※)規定の範囲を越えるリフローを必要とする場合は、必ずご連絡ください。
- ・赤外線ヒータを使用するとき、コンデンサの色や材質によって赤外線吸収率が異なる為、加熱の度合いに注意してください。

4) はんだ付け後の扱い

- ・プリント配線板にコンデンサをはんだ付けした後、コンデンサ本体を傾けたり又はひねったりしないでください。
- ・プリント配線板にコンデンサをはんだ付けした後、コンデンサを把手がわりにつかんでプリント配線板を移動しないでください。
- ・プリント配線板にコンデンサをはんだ付けした後、コンデンサに物をぶつけないでください。
また、プリント配線板を重ねるときコンデンサにプリント配線板、又は他の部品などが当たらないようにしてください。

5) プリント配線板の洗浄

(1)コンデンサは、以下の洗浄剤などでは洗浄できません。

- ・ハロゲン系溶剤:コンデンサ内部の腐食
洗浄剤がコンデンサ内部に侵入(拡散)し、洗浄剤が分解反応を起こして遊離された塩素(ハロゲンイオン)がアルミと反応し腐食が発生する場合があります。
- ・アルカリ系溶剤:アルミケースの腐食(溶解)
- ・テルペン、石油系溶剤:封ゴムの劣化
- ・トルエン、キシレン:封ゴムの劣化
- ・アセトン:表示の消失

・オゾン層破壊物質は、地球環境保護のため、洗浄剤としての使用は避けてください。

代替フロンも、地球環境保護の見地から将来的に使用できなくなりしますので、洗浄剤としての使用を推奨しません。

(2)洗浄する必要がある場合は、耐洗浄用コンデンサを使用し、カタログ又は納入仕様書に規定した洗浄剤、洗浄条件(温度、時間など)の範囲内で洗浄を行ってください。

- ・耐洗浄用コンデンサに対して洗浄するとき、洗浄剤の汚染管理(電導度、pH、比重、水分量など)を十分管理してください。
洗浄剤が汚染されていると、塩素(ハロゲンイオン)濃度が高くなり、コンデンサ内部が腐食する場合があります。
洗浄剤に対するフラックス濃度は、2%wt以下に管理してください。
- ・耐洗浄用コンデンサに対して洗浄の後、洗浄液の雰囲気中又は密閉容器で保管しないでください。
また、基板洗浄直後にコンデンサ封口部とプリント基板の間に洗浄剤が残留しないように充分強制乾燥を行ってください。
(カテゴリ上限温度以下)

3-3) Reflow Soldering

- ・Reflow soldering conditions (preheat, soldering temperature, reflow time, reflow cycle) should conform to the catalog or specification sheets.
- *Consult us for soldering beyond the specification.
- ・Be careful of the amount of heating with infrared heater, since infrared absorptance depends on color and material of capacitor sleeve.

4) Handling after Soldering

- ・Do not bend or twist capacitor body after soldering on PCB.
- ・Do not hold capacitors to transfer PCB after soldering.
- ・Keep capacitors from hitting something hard.
Also keep capacitors from touching another PCB or part on stacking PCB.

5) Cleaning after Soldering

(1)Do not clean capacitors with the following cleaning agents:

- ・Halogenated solvents: except for solvent resistant capacitor types, halogenated solvents can permeate the seal to corrode aluminum foil within capacitor.
- ・Alkali solvents: could attack and dissolve aluminum can.
- ・Terpene and Petroleum based solvents: could deteriorate packing rubber.
- ・Toluene and Xylene: could deteriorate packing rubber.
- ・Acetone: could blur print on sleeve.

・Do not use of ozone depleting agents to protect the global environment.

We don't recommend hydro-chlorofluorocarbon (HCFC) considering its impact on the environment.

(2)To clean up capacitors, select solvent-resistant capacitors.

Also use detergents and conditions stipulated in the catalog or specification sheets.

- ・Cleaning of solvent-resistant capacitors
Closely control cleaning solution (conductivity, pH, specific gravity, water content, etc.).
The concentration of flux (contamination) must be within 2wt% against the cleaning solution. Excessive contamination could include high content of chloride (halogen) ion, resulting in corrosion of capacitor.
- ・Do not keep PCB including capacitors in solvent-including environment or non-ventilated container. Be careful of drying not to leave detergent between capacitor surface and PCB. Use a circulating chamber for drying (within the maximum category temperature).

(3)洗淨方法

<対象品種> 小形アルミ電解コンデンサの100WV以下品

<洗淨剤>

パインアルファ ST-100S

クリンスルー 750H

IPA(イソプロピルアルコール)

<洗淨条件>

100WV以下品について、60°Cの液中浸漬、蒸気、超音波及びこれらの組合わせで5分間以内(5L、7L品は3分間以内)

- 商品によっては洗淨できませんので、納入仕様書の耐洗淨性の項目をご参照ください。また、上記以外の洗淨剤を御使用の際には、必ず一報ください。

6) 固定剤・コーティング剤

- ハロゲン系溶剤などを含有する固定剤・コーティング剤は使用しないでください。
- 固定剤・コーティング剤を使用する前に、基板とコンデンサの封口部にフラックス残渣及び汚れが残らないようにしてください。
- 固定剤・コーティング剤を使用する前に、洗淨剤などを乾燥させてください。
- 固定剤・コーティング剤により、封口部の全面をふさがないでください。

7) 燻蒸処理・消毒作業・ハロゲン系難燃剤について

- 以下の処理・環境条件は、コンデンサの内部電極やケース及び端子表面の腐食原因となる場合がありますので注意してください。
- (1)輸出入時の防虫対策の為のハロゲン化合物による木材パレットの燻蒸処理。
- (2)伝染病の感染を防止する為のハロゲン系の洗淨剤・消毒剤が直接コンデンサに付着する場合。
- (3)ハロゲン系難燃剤(臭素等)を多く含む部品(電子部品、及び筐体、絶縁フィルム等を含め)との共存環境下での使用、かつそれらの部品からハロゲンが遊離する懸念のある場合。

3.セット使用中の注意事項

- コンデンサの端子に直接触れないでください。
 - コンデンサの端子間を導電体でショートさせないでください。また、酸及びアルカリ水溶液などの導電性溶液をコンデンサにかけないでください。
 - 使用環境及び取付け環境が、コンデンサのカタログ又は納入仕様書に規定した定格性能の範囲内である事を確認し、使用してください。
 - 回路でのコンデンサ特性や使用中に問題のないことを十分にご確認のうえ使用して下さい。
- 納入仕様書や契約書で取り交わした保証条件を順守できる条件で使用して下さい。

(3)Cleaning Procedure

<Subjects> Miniature Aluminum Electrolytic Capacitors

100WV or lower

<Cleaning Solvents>

Pine Alpha ST-100S

Clean-thru 750H

IPA (isopropyl alcohol)

<Cleaning Condition>

For capacitors of 100WV or lower, immerse into the solution of the solvent, put into mist atmosphere, use ultrasonic vibration, or combine them for 5 minutes (3 minutes for 5L and 7L) up to 60C.

- Please refer to specification sheets, since some products are incompatible with cleaning. Please consult us to use a solvent other than the above.

6) Adhesives and Coating Materials

- Do not use adhesives or coating materials including halogens to fix Aluminum Electrolytic Capacitors.
- Be sure to clean up soldering flux and dirt between each capacitor and the surface of PCB before using an adhesive or a coating material.
- Fully dry solvents on capacitors before using adhesive or coating material.
- Do not cover up all the sealed surface of capacitor with adhesive or coating material.

7) Fumigation, Disinfection and Halogenated Flame Retardant

- Note that treatments or environments shown below may cause corrosion inside and outside of capacitor (foils, aluminum can, terminal):
- (1)Fumigation of wooden pallets to disinfect vermin before shipment.
- (2)Direct deposition to capacitors of halogenated detergents or antiseptics for preventing infection of epidemic diseases contact.
- (3)Coexistence of components or parts containing halogenated flame retardant agent (bromine etc.).

3.Cautions in Use on Set

- Do not touch the terminals of capacitor.
 - Do not short-circuit between terminals of capacitor. Keep capacitors from conductive solutions, such as acid and alkali.
 - Ensure that operational environment is satisfied with the conditions mentioned in the catalog or specification sheets.
 - Please use the capacitor after thoroughly confirming that there are no problems with the capacitor characteristics in the circuit or during use.
- Use the capacitor under conditions that allow compliance with the warranty conditions described in these specifications and contract documents.

4.保守点検

- 産業用機器に使用されているコンデンサについては、定期点検をしてください。
- 定期点検は、次の内容を行ってください。
 - ①外観：開弁、液漏れなどの著しい異常の有無。
 - ②電気的性能：漏れ電流、静電容量、損失角の正接及びカタログ又は納入仕様書に規定の項目。

5.万一の場合

- セット使用中、コンデンサが開弁し、ガスが見えたときは、セットのメイン電源を切るか又は電源コードのプラグをコンセントから抜いてください。
- コンデンサの圧力弁作動時、+100℃を超える高温ガスが噴出しますので、顔を近づけないでください。
- 噴出したガスが目に入ったり、吸い込んだりした場合には、直ちに水で目を洗ったり、うがいをしてください。
- コンデンサの電解液は、なめないでください。電解液が皮膚に付いたときは、石鹸で洗い流してください。

6.保管の条件

- コンデンサを高湿度・高湿度で保管しないでください。室内で5℃～35℃の温度、75%以下の相対湿度で保管してください。
- コンデンサに直接、水、塩水及び油がかかる環境で保管しないでください。
- コンデンサを有害ガス（硫化水素、亜硫酸、亜硝酸、塩素、アンモニア、臭素、臭化メチルなど）が充満する環境で保管しないでください。
- コンデンサをオゾン、紫外線及び放射線が照射される環境で保管しないでください。
- コンデンサを酸性及びアルカリ性溶剤がかかる環境で保管しないでください。

7.廃棄の場合

- コンデンサを廃棄する場合には、次のいずれかの方法を取ってください。
 - ①コンデンサに穴を開けるか又は十分つぶしてから高温焼却（800℃以上）してください。
 - ②コンデンサを焼却しない場合は、専門の産業廃棄物処理業者に渡してください。

4.Maintenance

- Periodically inspect capacitors used for industrial equipment. Check the following points at the inspection.
 - ①Visual inspection of pressure relief vent operation and leakage of electrolyte.
 - ②Electrical characteristics: leakage current, capacitance, dissipation factor and other items specified in the catalog or specification Sheets.

5.Emergency Action

- If you find pressure relief vent operation or gas evolution from a capacitor, shut off the main switch of the equipment or pull the power cable from the outlet immediately.
- Keep your face off from the capacitor with vent operation. Extremely hot gas (over 100℃) may blow out of it. In case of eye contact or inhalation of gas, immediately flush the eye(s) with large amount of clean water or gargle the throat.
- Do not lick electrolyte. In case of electrolyte reach to skin, wash with soap and water.

6.Storage Condition

- Do not keep Aluminum Electrolytic Capacitors in hot and/or humid atmosphere. Recommended storage condition is 5℃-35℃ in temperature and not higher than 75% in relative humidity.
- Do not keep Aluminum Electrolytic Capacitors in a condition where spray of water, saltwater or oil is expected.
- Do not store Aluminum Electrolytic Capacitors in an environment full of hazardous gas (e.g. hydrogen sulfide, sulfurous acid gas, nitrous acid, chlorine gas, ammonia, bromine gas, methyl bromide).
- Do not keep Aluminum Electrolytic Capacitors under exposure to ozone, ultraviolet rays or radiation.
- Do not keep Aluminum Electrolytic Capacitors under exposure to acid or alkaline environment.

7.Disposal

- Please take either of the following actions in case of disposal.
 - ①Incineration (at high temperature over 800℃) after piercing or crushing capacitor body.
 - ②Consignment to specialists of industrial waste.

※詳細はJEITA RCR-2367Dをご覧ください。

JEITA RCR-2367D

「電子機器用固定アルミニウム電解コンデンサの安全アプリケーションガイド」

〔社団法人 電子技術情報産業協会、1995年3月制定、2017年10月改正、2019年3月追補1制定〕

For further details:

Please refer to JEITA RCR-2367D (Safety Application Guide for fixed aluminum electrolytic capacitors for use in electronic equipment).

[Technical Report of Japan Electronics and Information Technology Industries Association (established in March 1995, Revised in March 2019)].



極めて高信頼性を要求される回路、社会的に重大な影響を与えかつ直接生命・身体に対する危険を伴う用途（交通輸送機器・医療機器・航空機器・宇宙機器・原子力用機器等）に使用される場合には、事前にご相談ください。



Our products is not used in special circuit(transportation equipment , medical equipment , aerospace equipment, space equipment, nuclear equipment etc) where a defect in this component may cause the loss of human life or other significant damage in the case of high reliability application circuit/equipment , Please contact us in advance.

◆代表的な故障モードとその要因/TYPICAL FAILURE MODES AND THEIR FACTORS

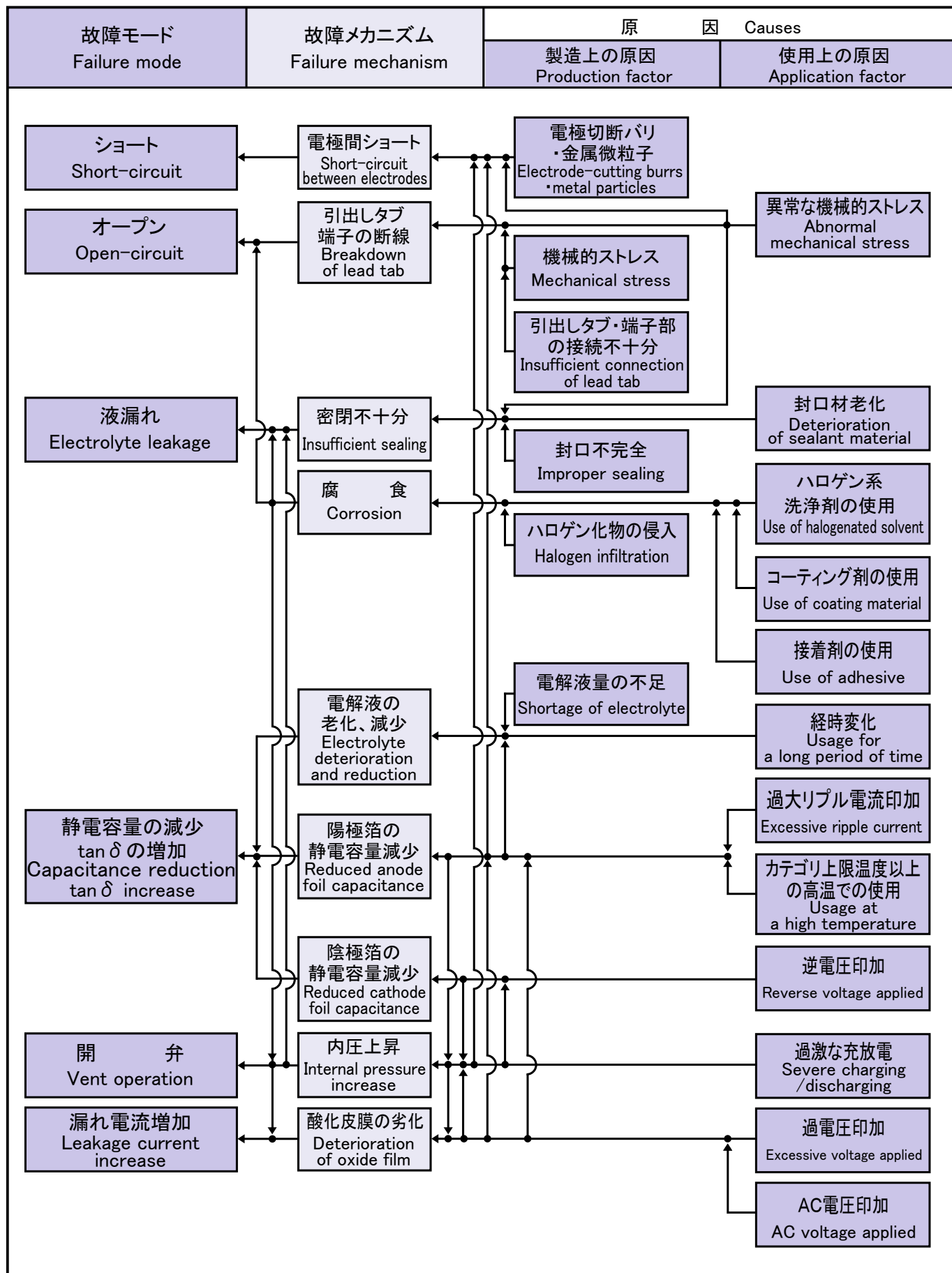

◆チップ形 呼称方法/CHIP TYPE PART NUMBER

□□□ 定格電圧 Rated Voltage	□□□□ シリーズ名 Series	□□□□□ 静電容量 Capacitance	□ 静電容量許容差 Capaciatnce Tolerance	□□□ 副記号 Option ※1	DXL ケースサイズ Case Size																									
↑		↑	↑		↑																									
<table border="1" style="width:100%; border-collapse: collapse;"> <thead> <tr> <th>Rated Voltage(Vdc)</th> <th>Code</th> </tr> </thead> <tbody> <tr><td>6.3</td><td>6.3</td></tr> <tr><td>10</td><td>10</td></tr> <tr><td>25</td><td>25</td></tr> <tr><td>100</td><td>100</td></tr> </tbody> </table>	Rated Voltage(Vdc)	Code	6.3	6.3	10	10	25	25	100	100		<table border="1" style="width:100%; border-collapse: collapse;"> <thead> <tr> <th>Cap.(μF)</th> <th>Code</th> </tr> </thead> <tbody> <tr><td>4.7</td><td>4R7</td></tr> <tr><td>220</td><td>220</td></tr> <tr><td>3300</td><td>3300</td></tr> </tbody> </table>	Cap.(μF)	Code	4.7	4R7	220	220	3300	3300	<table border="1" style="width:100%; border-collapse: collapse;"> <thead> <tr> <th>Tolerance</th> <th>Code</th> </tr> </thead> <tbody> <tr><td>±20%</td><td>M</td></tr> </tbody> </table>	Tolerance	Code	±20%	M		<table border="1" style="width:100%; border-collapse: collapse;"> <tbody> <tr><td>4X6.1</td></tr> <tr><td>8X10.5</td></tr> <tr><td>16X21.5</td></tr> </tbody> </table>	4X6.1	8X10.5	16X21.5
Rated Voltage(Vdc)	Code																													
6.3	6.3																													
10	10																													
25	25																													
100	100																													
Cap.(μF)	Code																													
4.7	4R7																													
220	220																													
3300	3300																													
Tolerance	Code																													
±20%	M																													
4X6.1																														
8X10.5																														
16X21.5																														
<p>ご注文の際には、定格電圧、シリーズ名、静電容量、ケースサイズまでご連絡ください。 Please Indicate the abobe information when ordring</p> <p>例): Example 35 TZV 330 M 10X10.5</p>																														

※1 副記号: 標準品はblankとなります。
Option : Standard item is blank.

◆リード線形 呼称方法/RADIAL LEAD TYPE PART NUMBER

□□□ 定格電圧 Rated Voltage	□□□□ シリーズ名 Series	□□□□□ 静電容量 Capacitance	□ 静電容量許容差 Capaciatnce Tolerance	□□□ 副記号 Option ※2	□□ リード加工記号 Lead Forming ※3	DXL ケースサイズ Case Size																											
↑		↑	↑	↑	↑	↑																											
<table border="1" style="width:100%; border-collapse: collapse;"> <thead> <tr> <th>Rated Voltage(Vdc)</th> <th>Code</th> </tr> </thead> <tbody> <tr><td>6.3</td><td>6.3</td></tr> <tr><td>10</td><td>10</td></tr> <tr><td>25</td><td>25</td></tr> <tr><td>100</td><td>100</td></tr> </tbody> </table>	Rated Voltage(Vdc)	Code	6.3	6.3	10	10	25	25	100	100		<table border="1" style="width:100%; border-collapse: collapse;"> <thead> <tr> <th>Cap.(μF)</th> <th>Code</th> </tr> </thead> <tbody> <tr><td>0.47</td><td>0R47</td></tr> <tr><td>10</td><td>10</td></tr> <tr><td>1000</td><td>1000</td></tr> </tbody> </table>	Cap.(μF)	Code	0.47	0R47	10	10	1000	1000	<table border="1" style="width:100%; border-collapse: collapse;"> <thead> <tr> <th>Tolerance</th> <th>Code</th> </tr> </thead> <tbody> <tr><td>±20%</td><td>M</td></tr> </tbody> </table>	Tolerance	Code	±20%	M	<table border="1" style="width:100%; border-collapse: collapse;"> <tbody> <tr><td>EFC etc</td></tr> </tbody> </table>	EFC etc	<table border="1" style="width:100%; border-collapse: collapse;"> <tbody> <tr><td>TA, KC CA etc</td></tr> </tbody> </table>	TA, KC CA etc	<table border="1" style="width:100%; border-collapse: collapse;"> <tbody> <tr><td>5X11</td></tr> <tr><td>10X12.5</td></tr> <tr><td>12.5X40</td></tr> </tbody> </table>	5X11	10X12.5	12.5X40
Rated Voltage(Vdc)	Code																																
6.3	6.3																																
10	10																																
25	25																																
100	100																																
Cap.(μF)	Code																																
0.47	0R47																																
10	10																																
1000	1000																																
Tolerance	Code																																
±20%	M																																
EFC etc																																	
TA, KC CA etc																																	
5X11																																	
10X12.5																																	
12.5X40																																	
<p>ご注文の際には、定格電圧、シリーズ名、静電容量、リード加工、ケースサイズまでご連絡ください。 Please Indicate the abobe information when ordring</p> <p>例): Example ・ロング品 Long lead type 50 PX 2R2 M EFC 10X10.5 ・テーピング品 Taping type 35 ZLJ 220 M TA 8X16</p>																																	

※2 副記号: 各シリーズのページをご確認ください。
Option : Please confirm each series page.

※3 リード加工記号: テーピング仕様及びリード線加工仕様の項目をご参照ください。
Lead Forming : Please refer to TAPING SPECIFICATIONS and LEAD CUTTING FORMING SPECIFICATIONS.

◆リード線端子形 梱包単位/RADIAL LEAD TYPE PACKAGING SPECIFICATION

製品サイズ SIZE (mm)		ロングリード品		リード加工品		テーピング品 TAPING
		LONG LEAD		LEAD FORMING		
		バラ梱包 BULK PACKAGE	整列梱包 ALIGNED PACKAGE	バラ梱包 BULK PACKAGE	整列梱包 ALIGNED PACKAGE	
φ4	4x5	5000	—	5000	—	2000
	4x7	5000	—	5000	—	2000
φ5	5x5	5000	—	5000	—	2000
	5x7	5000	—	5000	—	2000
	5x11	3000	—	5000	—	2000
φ6.3	6.3x5	3000	—	5000	—	2000
	6.3x7	3000	—	5000	—	2000
	6.3x11	2000	—	3000	—	2000
	6.3x25	1000	—	1000	—	—
	6.3x30	1000	—	1000	—	—
	6.3x40	1000	—	1000	—	—
	6.3x50	1000	—	1000	—	—
φ8	8x5	3000	—	5000	—	1000
	8x7	3000	—	5000	—	1000
	8x7.5	2000	—	2000	—	1000
	8x9	2000	—	2000	—	1000
	8x10.8	2000	—	2000	—	1000
	8x11.5	2000	—	2000	—	1000
	8x16	1000	—	1000	—	1000
	8x20	1000	—	1000	—	1000
	8x25	—	500	—	500	—
	8x30	—	500	—	500	—
	8x35	—	500	—	500	—
	8x40	—	500	—	500	—
	8x45	—	500	—	500	—
	8x50	—	500	—	500	—
8x55	—	500	—	500	—	
8x60	—	500	—	500	—	
φ10	10x9	1000	—	1000	—	500
	10x10	1000	—	1000	—	500
	10x12.5	1000	—	1000	—	500
	10x16	1000	—	1000	—	500
	10x20	1000	500	1000	500	500
	10x23	1000	—	1000	—	500
	10x25	1000	500	1000	500	500
	10x28	1000	500	1000	500	500
	10x30	—	500	—	500	—
	10x35	—	500	—	500	—
	10x40	—	500	—	500	—
	10x45	—	500	—	500	—
	10x50	—	500	—	500	—
	10x55	—	500	—	500	—
10x60	—	500	—	500	—	

製品サイズ SIZE (mm)		ロングリード品		リード加工品		テーピング品 TAPING
		LONG LEAD		LEAD FORMING		
		バラ梱包 BULK PACKAGE	整列梱包 ALIGNED PACKAGE	バラ梱包 BULK PACKAGE	整列梱包 ALIGNED PACKAGE	
φ12.5	12.5x16	1000	—	1000	500*	500
	12.5x20	1000	500	1000	500*	500
	12.5x25	1000	500	1000	500*	500
	12.5x30	600	500	600	500*	500
	12.5x35	600	500	600	500*	500
	12.5x40	600	500	600	500*	500
	12.5x45	—	500	—	500	—
	12.5x50	—	500	—	500	—
	12.5x55	—	500	—	500	—
	12.5x60	—	500	—	500	—
φ14.5	14.5x20	—	500	—	500	—
	14.5x25	—	500	—	500	—
	14.5x30	—	500	—	500	—
	14.5x31.5	—	500	—	500	—
	14.5x35	—	500	—	500	—
	14.5x40	—	500	—	500	—
	14.5x45	—	500	—	500	—
14.5x50	—	500	—	500	—	
φ16	16x16	600	—	600	400*	250
	16x20	600	200	600	400*	250
	16x25	600	200	600	400*	250
	16x30	—	200	—	200	250
	16x31.5	—	200	—	200	250
	16x35	—	200	—	200	250
	16x35.5	—	200	—	200	250
	16x40	—	200	—	200	250
	16x45	—	200	—	200	—
	16x50	—	200	—	200	—
φ18	18x16	500	—	—	200	250
	18x20	500	200	—	200	250
	18x25	500	200	—	200	250
	18x30	—	200	—	200	250
	18x31.5	—	200	—	200	250
	18x35	—	200	—	200	250
	18x35.5	—	200	—	200	250
	18x40	—	200	—	200	250
	18x45	—	200	—	200	—
	18x50	—	200	—	200	—

* 輸出用は整列梱包が標準となります。
 aligned package is standard for exporting carton.

・梱包単位につきましては上記と異なる場合がございます。
 There are some differences between actual package quantity and above list.

◆テーピング仕様/TAPING SPECIFICATIONS

◆ラジアルリード形(04形)テーピング形状寸法図/DIMENSIONS

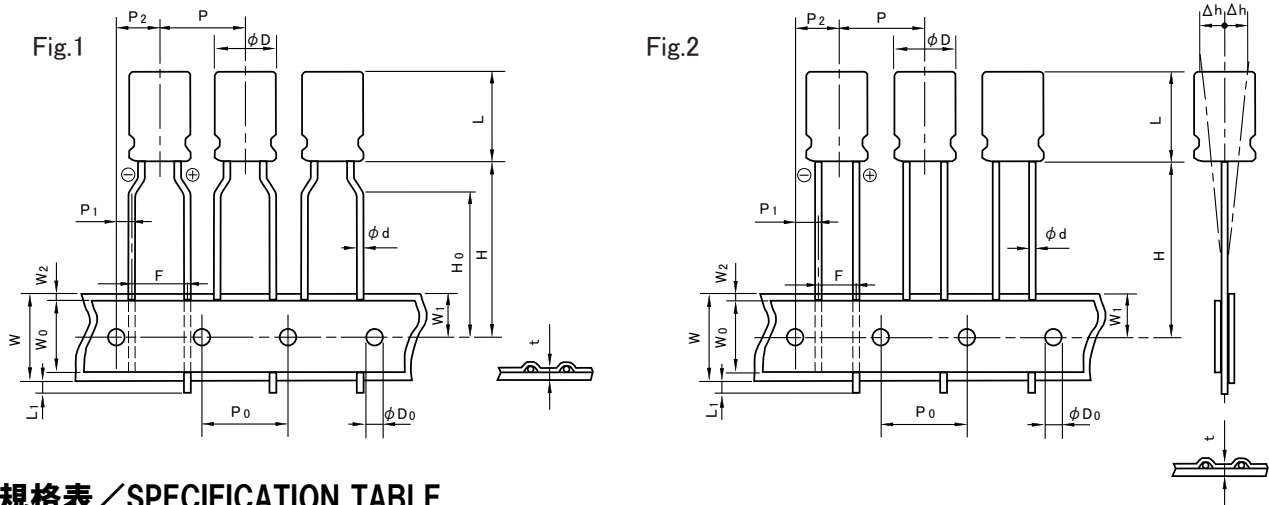

◆規格表/SPECIFICATION TABLE

項目 Item	記号 Code	5mmHeight		7mm or 7.5mm Height				※許容差 Tolerance
		φ4~φ8		φ4~φ6.3	φ4~φ6.3	φ8		
リード加工記号 Taping code		T5	TZ	T5	TZ	TA	T7	
形状寸法図 Applicable Fig. No.		Fig.2	Fig.1	Fig.2	Fig.1	Fig.1	Fig.2	
リード線径 Dia. of lead	φ d	0.45		0.45				±0.05
本体高さ Height of body	L	6.5		8.5				MAX
ポディーピッチ Distance from center to center of next body	P	12.7		12.7				±1.0
送り穴ピッチ Distance from center to center of next driving hole	P ₀	12.7		12.7				±0.2
送り穴位置ズレ (台紙上端との界面にて規定) Distance between center of driving hole and lead (at the upper edge of the carrier tape)	P ₁	5.1	3.85	5.1	3.85	4.6	±0.5	
送り穴位置ズレ Distance between center of driving hole and body	P ₂	6.35		6.35				±1.0
リードピッチ (台紙上端との界面にて規定) Pitch of lead (at the upper edge of the carrier tape)	F	2.5	5.0	2.5	5.0	3.5	+0.8 -0.2	
台紙幅 Width of mounting tape	W	18.0		18.0				±0.3
粘着テープ幅 Width of adhesive tape	W ₀	5.0		5.0				MIN
送り穴位置ズレ Distance between center of driving hole and mounting tape edge	W ₁	9.0		9.0				±0.5
粘着テープズレ Max. allowable distance between mounting and adhesive tape edges	W ₂	1.5		1.5				MAX
ボディ下面位置 Distance between center of driving hole and bottom of body	H	17.5		17.5		20.0		±0.75
リードクリンチ高さ Distance between center of driving hole and clinch part of lead	H ₀	-	16.0	-	16.0		-	±0.5
リード線はみ出し End of lead	L ₁	0.5		0.5				MAX
送り穴径 Dia. of driving hole	φ D ₀	4.0		4.0				±0.2
ボディの倒れ Off alignment of body top	Δh	2.0		2.0				MAX
テープの総厚み Sum of thickness for mounting and adhesive tape without lead dia	t	0.6		0.6				±0.3
梱包数量(個) Quantity (pcs)		2000 (φ8:1000)						

※個別に許容差が設定されている場合は、その数値が優先されます。
 ※For the case that tolerance is specified individually, the value shall have the priority.

◆テーピング仕様/TAPING SPECIFICATIONS

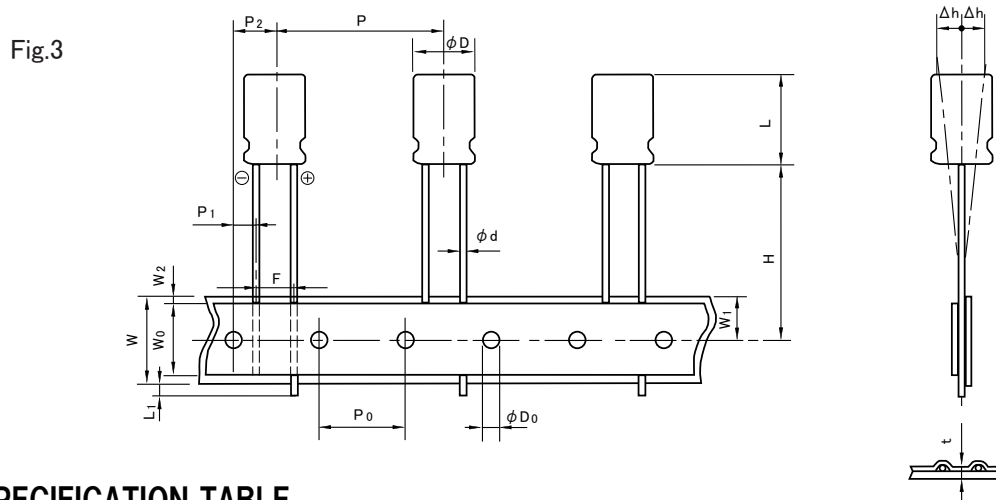

◆規格表/SPECIFICATION TABLE

項目 Item	記号 Code	9mm or more Height						※許容差 Tolerance	
		φ 5, φ 6.3	φ 8	φ 10	φ 12.5	φ 16	φ 18		
リード加工記号 Taping code		T1	TA	TA	T7	T8	G4	GC	
形状寸法図 Applicable Fig. No.		Fig.2	Fig.1	Fig.1	Fig.2	Fig.2	Fig.2	Fig.3	
リード線径 Dia. of lead	φ d	0.5	0.6			0.8		±0.05	
本体高さ Height of body	L	13.0	22.0	30.0	42.0		MAX		
ボディーピッチ Distance from center to center of next body	P	12.7			15.0	30.0		±1.0	
送り穴ピッチ Distance from center to center of next driving hole	P ₀	12.7			15.0	15.0±0.3		±0.2	
送り穴位置ズレ (台紙上端との界面にて規定) Distance between center of driving hole and lead (at the upper edge of the carrier tape)	P ₁	5.1	3.85	4.6	3.85	5.0	3.75	±0.5	
送り穴位置ズレ Distance between center of driving hole and body	P ₂	6.35			7.5		±1.0		
リードピッチ (台紙上端との界面にて規定) Pitch of lead (at the upper edge of the carrier tape)	F	2.5	5.0	3.5	5.0±0.8	7.5±0.8		+0.8 -0.2	
台紙幅 Width of mounting tape	W	18.0						±0.3	
粘着テープ幅 Width of adhesive tape	W ₀	5.0						MIN	
送り穴位置ズレ Distance between center of driving hole and mounting tape edge	W ₁	9.0						±0.5	
粘着テープズレ Max. allowable distance between mounting and adhesive tape edges	W ₂	1.5						MAX	
ボディ下面位置 Distance between center of driving hole and bottom of body	H	18.5	20.0	18.5			^{+0.75} _{-0.5}	±0.75	
リードクリンチ高さ Distance between center of driving hole and clinch part of lead	H ₀	-	16.0	-	-			±0.5	
リード線はみ出し End of lead	L ₁	0.5						MAX	
送り穴径 Dia. of driving hole	φ D ₀	4.0						±0.2	
ボディの倒れ Off alignment of body top	Δh	2.0						MAX	
テープの総厚み Sum of thickness for mounting and adhesive tape without lead dia	t	0.6						±0.3	
梱包数量(個) Quantity (pcs)		2000	1000	500	250				

※個別に許容差が設定されている場合は、その数値が優先されます。

※For the case that tolerance is specified individually, the value shall have the priority.

◆リード線加工仕様／LEAD CUTTING FORMING SPECIFICATIONS

プリント基板取り付けが容易となる様、リードフォーミング、リードカットを行った製品及びプリント基板自立形用に特殊加工(キンクフォーミング)を行った製品を製造しております。

Rubycon provides lead-formed and lead-cut products to facilitate mounting on printed circuit boards, as well as products with leads specially processed (kink formed) for self supporting insertions to printed circuit boards.

・リードフォーミング
Lead forming
($\phi 5 \sim \phi 8$)
Lead forming code : FA

ϕD	5	6.3	8
ϕd	0.5		0.6
F	5.0		

・リードカット
Lead cutting
($\phi 5 \sim \phi 18$)
Lead cutting code : CA
CC
CE

ϕD	5	6.3	8	10	12.5	14.5	16	18
H	5.0.....(CA) 4.0.....(CC) 3.5.....(CE)							
ϕd	0.5		0.6		0.8			
F	2.0	2.5	3.5	5.0	7.5			

・キンクリードフォーミング
Kinked lead forming
($\phi 5 \sim \phi 8$)
Kinked lead forming code : KC

・キンクリードカット
Kinked lead forming
($\phi 10 \sim \phi 18$)
Kinked lead cutting code : KC

ϕD	5	6.3	8	10	12.5	14.5	16	18
H1	4.5							
H2	2.8							
H3	2.5		-					
F	5.0				7.5			
P	1.0							
E	1.2			1.3				
ϕd	0.5		0.6		0.8			

・横置き対応品 ($\phi 10 \sim \phi 18$) / Low profile with horizontal mounting

タイプA
Type A

タイプB
Type B

ϕD	10,12.5				14.5,16,18			
Code	RI	RK	RX	SG	RI	RK	RX	SG
ϕd	0.6				0.8			
F	5.0				7.5			
H	4.0		3.5		4.0		3.5	
Type	A	B	A	B	A	B	A	B

適応 object: 表面実装形コンデンサ Chip type capacitors

◆テーピング仕様/TAPING SPECIFICATIONS

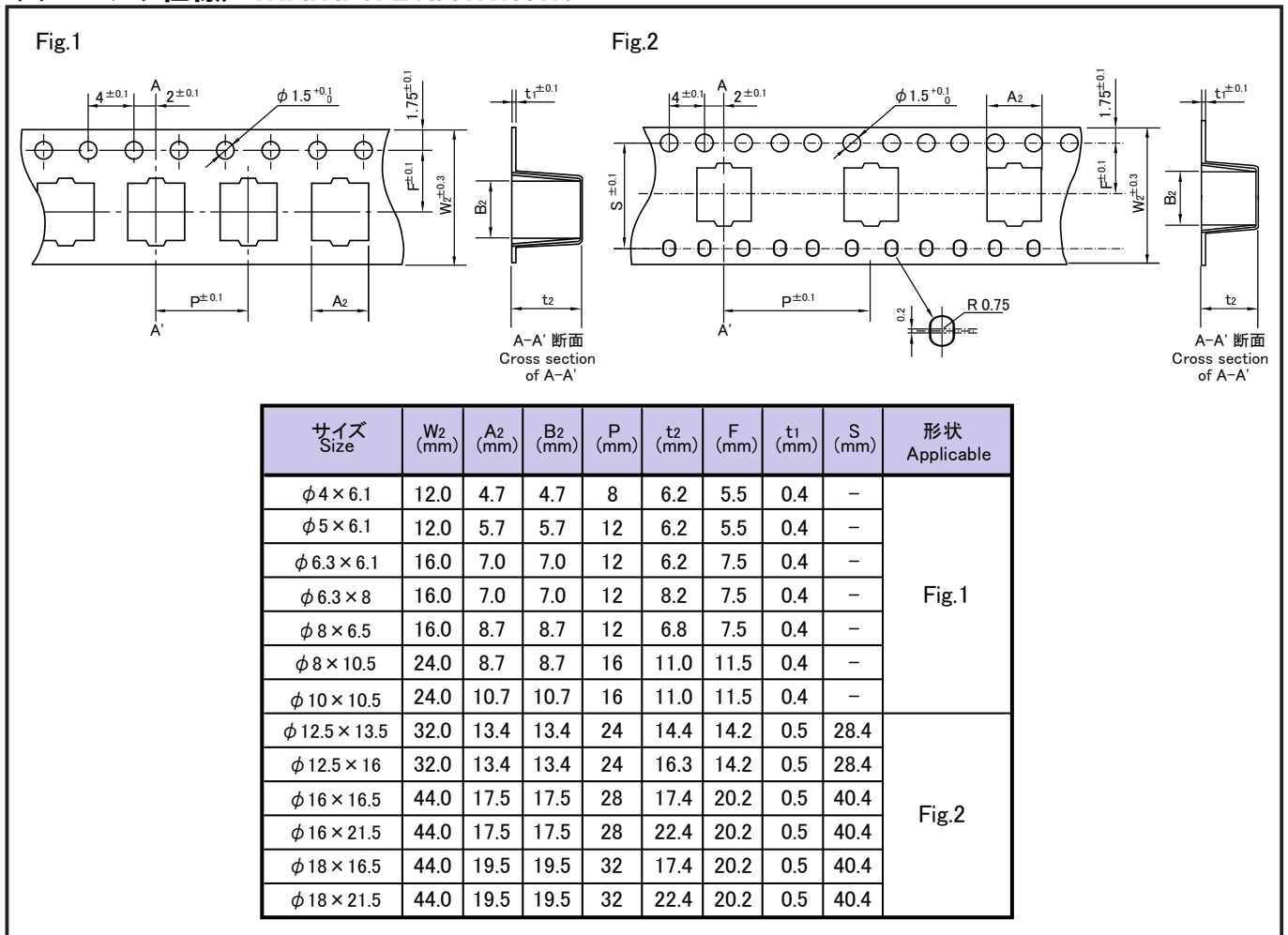

◆リール/TAPING REEL AND PACKING QUANTITY

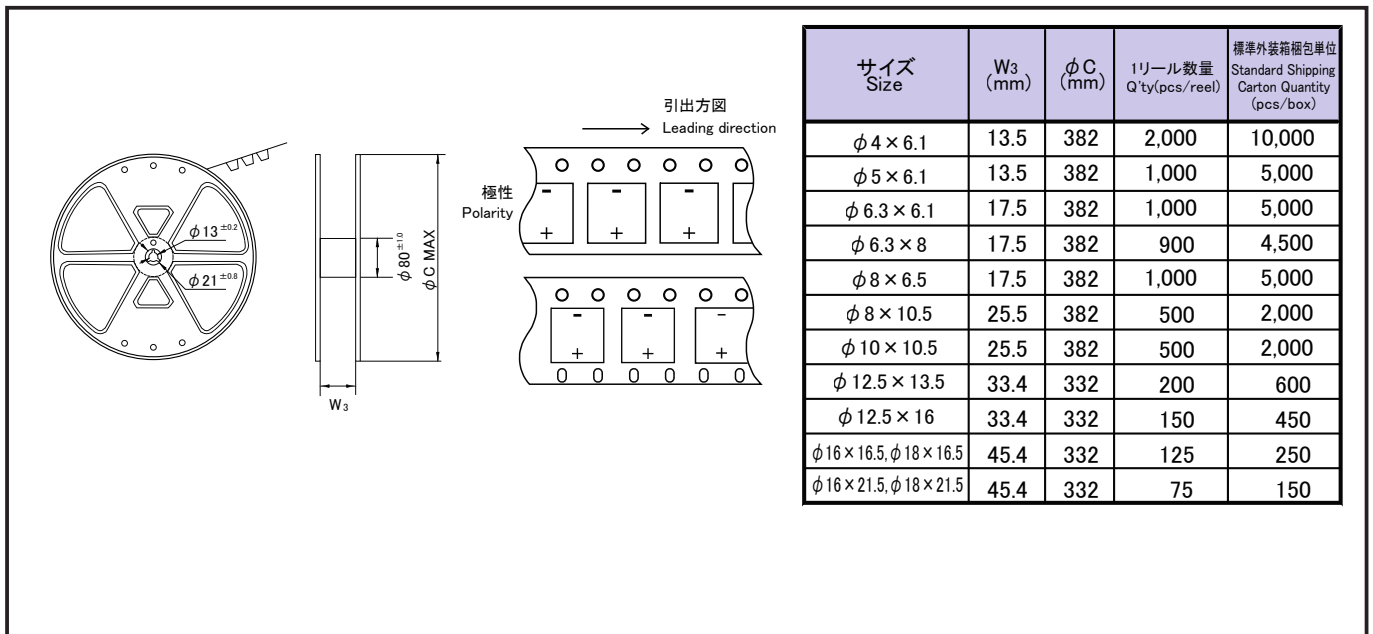

◆鉛フリータイプリフロー許容条件／LEAD FREE TYPE REFLOW SOLDERING CONDITION

●ケースサイズφ4～φ10mm品 Size φ4～φ10

- 1) コンデンサ表面温度がT°C以下である事。
Temperature at surface of capacitor shall not exceed T°C.
- 2) コンデンサ表面温度は200°C以上の時間がt秒、T₁°C以上の時間がt₁秒を越えない事。
Period that temperature at surface of capacitor becomes more than 200°C and T₁°C shall not exceed t and t₁ seconds, respectively.
- 3) 予熱は150°C～180°Cで120秒以内である事。
Preheat shall be made at 150°C～180°C and for maximum 120 seconds.

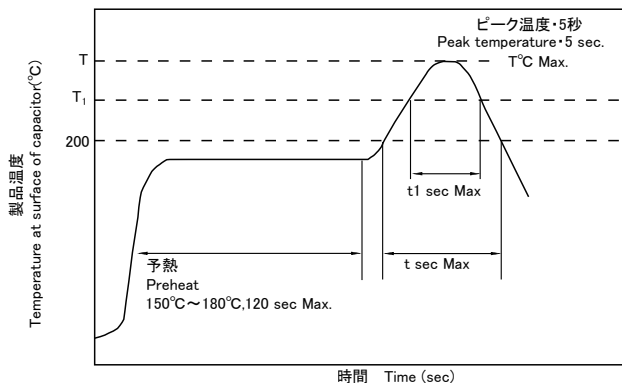

Series	Size	Rated Voltage	T(°C) ①	T ₁ (°C)	t(sec) ②	t ₁ (sec) ③	Reflow cycle
SEV SKV SGV	φ4～φ6.3	≤50Vdc	250	230	70	30	2
TZV TKV TPV TLV TRV TXV THV TGV TAV TSV TNV	φ8	≤100Vdc	245	230	70	30	2
	φ10		240	230	60	30	2
	φ8,10	≥160Vdc	240	230	50	20	2
SJV SLV	φ4～φ6.3	≤50Vdc	240	220	60	40	1
JGV JZV	φ4～φ6.3	≤50Vdc	260	217	-	60	2
	φ8,10		250	217	-	60	2

①ピーク温度 Peak temperature
 ②200°Cを超える時間<MAX> Time more than 200°C
 ③T₁を超える時間<MAX> Time more than T₁
 ※許容条件を越える場合は御相談ください。
 Please contact us if the condition is over the maximum.

●ケースサイズφ12.5～φ18mm品 Size φ12.5～φ18

- 1) コンデンサ表面温度がT°C以下である事。 Temperature at surface of capacitor shall not exceed T°C.
- 2) コンデンサ表面温度は200°C以上の時間がt秒、T₁°C以上の時間がt₁秒を越えない事。
Period that temperature at surface of capacitor becomes more than 200°C and T₁°C shall not exceed t and t₁ seconds, respectively.
- 3) 予熱は100°C～180°Cで150秒以内である事。
Preheat shall be made at 100°C～180°C and for maximum 150 seconds.

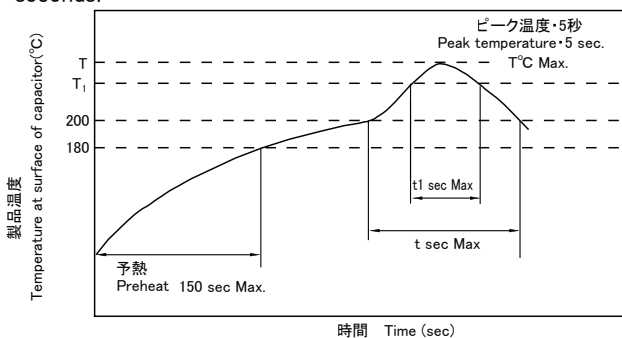

Series	Size	Rated Voltage	T(°C) ①	T ₁ (°C)	t(sec) ②	t ₁ (sec) ③	Reflow cycle
SEV SKV SGV	φ12.5 ～φ18	≤50Vdc	240	230	60	30	2
TLV TRV TGV TSV		63Vdc 100Vdc	240	230	50	20	2
		≥160Vdc	230	220	50	20	2

①ピーク温度 Peak temperature
 ②200°Cを超える時間<MAX> Time more than 200°C
 ③T₁を超える時間<MAX> Time more than T₁
 ※許容条件を越える場合は御相談ください。
 Please contact us if the condition is over the maximum.

◆推奨ランドパターン／RECOMMENDED LAND PATTERN

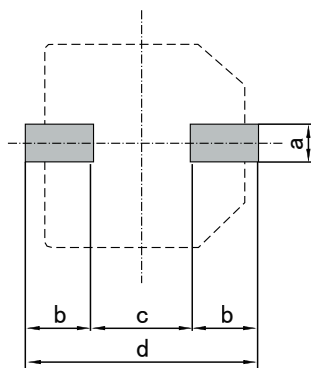

Size	a	b	c	d
φ4	1.6	2.6	1.0	6.2
φ5	1.6	3.0	1.4	7.4
φ6.3	1.6	3.5	2.1	9.1
φ8X6.5	1.6	4.5	2.1	11.1
φ8X10.5	2.2	4.1	3.0	11.2
φ10X10.5	2.2	4.3	4.5	13.1
φ12.5	2.5	6.0	5.0	17
φ16	3	6.5	8.0	21
φ18	3	7.5	8.0	23

◆補助端子付き耐振動構造品
Vibration proof packages with the dummy terminal

- ケースサイズφ8以上のチップ形コンデンサに対し、耐振動構造対応します。
For chip Aluminum electrolytic capacitors more than case size φ 8, vibration proof packages supports.



◆呼称方法/PART NUMBER

□□□	□□□□	□□□□□	□	□□□	VB	DXL
定格電圧 Rated Voltage	シリーズ名 Series	静電容量 Capacitance	静電容量許容差 Capacitance Tolerance	副記号 Option	耐振動構造品記号 Vibration proof package No.	ケースサイズ Case Size

◆寸法図/DIMENSIONS

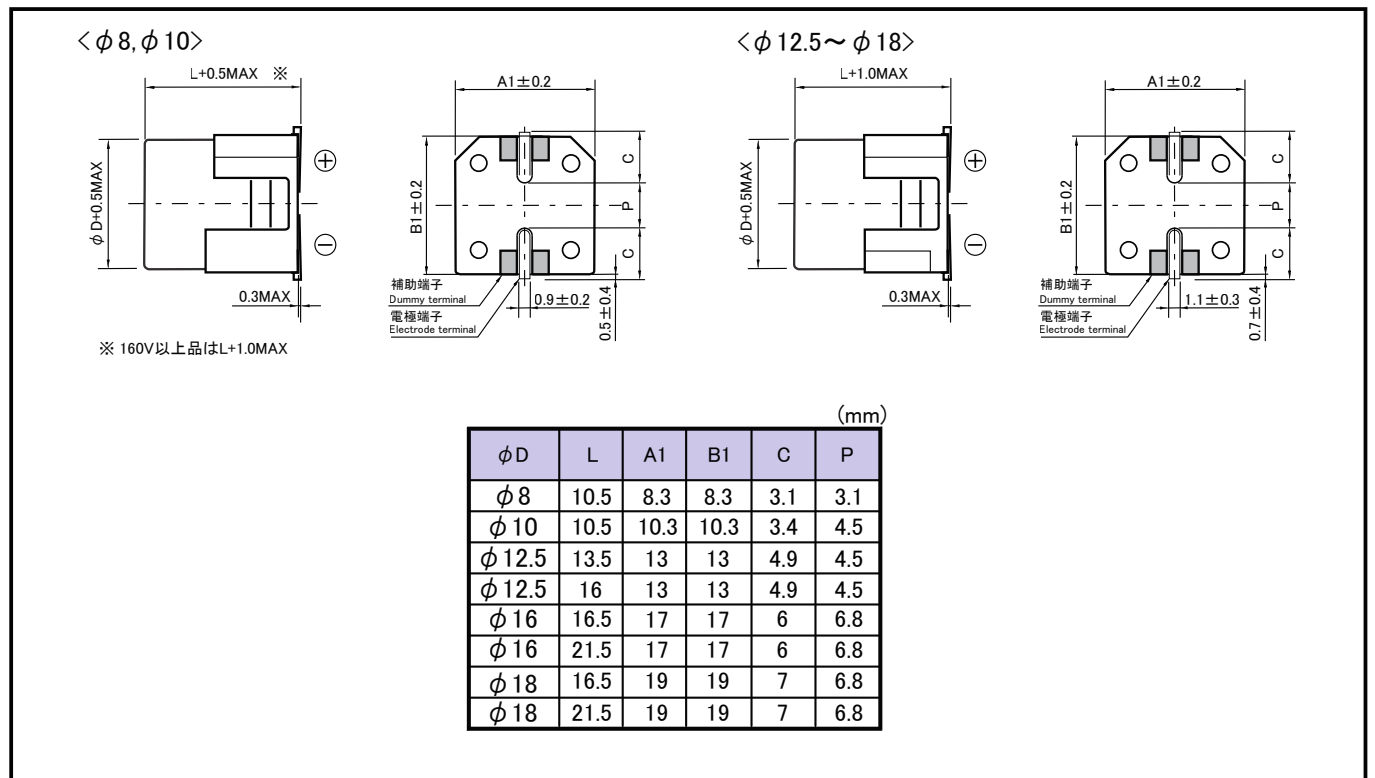

◆推奨ランドパターン/RECOMMENDED LAND PATTERN

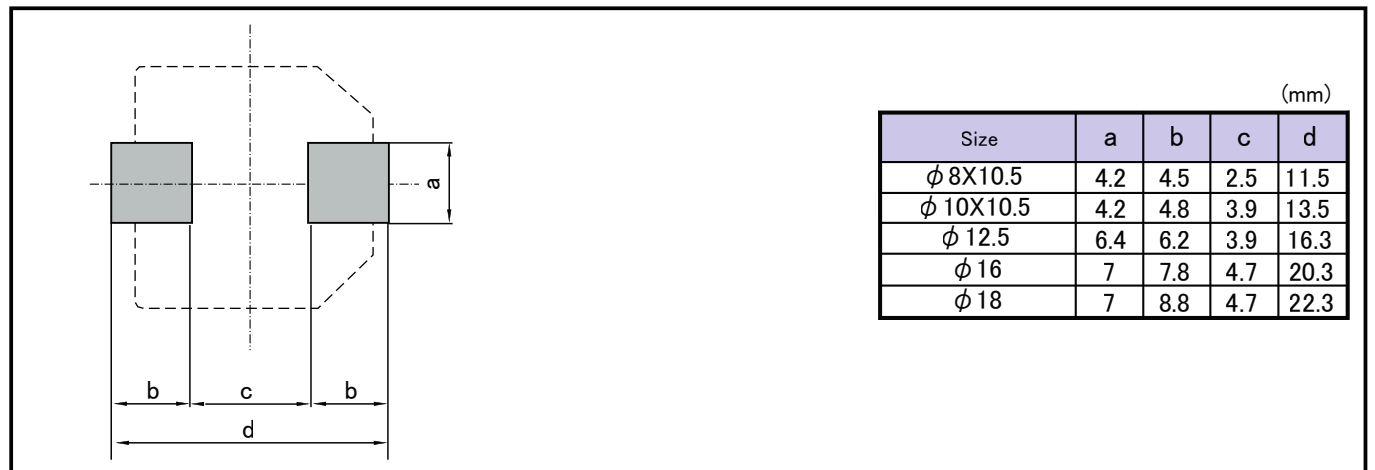

◆基板自立形 呼称方法/SNAP-IN TYPE PART NUMBER

□□□		□□□□		□□□□□		□	□□□	□□	DXL
定格電圧 Rated Voltage		シリーズ名 Series		静電容量 Capacitance		静電容量許容差 Capacitance Tolerance	副記号 Option	端子記号 Terminal Code	ケースサイズ Case Size
Rated Voltage(Vdc)	Code	Cap.(μ F)	Code	Tolerance	Code	Option	Code	Terminal Type	Code
50	50	22	22	$\pm 20\%$	M	PETスリーブ、底板なし PET Sleeve without plate	EFC	標準端子 Standard Terminal	SN
100	100	560	560	$\pm 10\%$	K	PVCスリーブ、底板なし PVC Sleeve without plate	OOE	逆差し防止端子 Keying Terminal	EN
450	450	1000	1000			PVCスリーブ、底板あり PVC Sleeve with plate	なし Blank	耐振・逆差し防止端子 Vibration proof terminal	LN
									20X25 22X30 25X35 30X40 35X45

ご注文の際には、定格電圧、シリーズ名、静電容量、底板、端子形状、ケースサイズまでご連絡ください。
Please Indicate the above information when ordering .

例): Example 200 MXG 820 M EFC SN 25X35
 450 USG 330 M EFC SN 30X35

◆基板自立形 梱包単位/SNAP-IN TYPE PACKAGING SPECIFICATION

製品サイズ SIZE (mm)	梱包単位 PACKAGE QUANTITY (pcs/box)
$\phi 20$	200
$\phi 22$	200
$\phi 25$	200
$\phi 30$	100
$\phi 35$	100 (BN端子 Terminal Code BN: 50)
$\phi 40$	50
$\phi 45$	50

◆端子形状/Terminal TYPE

●標準端子形状(Standard terminal type)

端子記号 Terminal Code	SN
-----------------------	----

端子材料 Terminal Material	Fe/Cu/Sn
---------------------------	----------

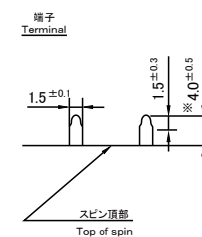
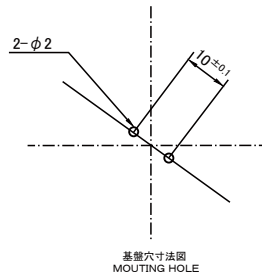
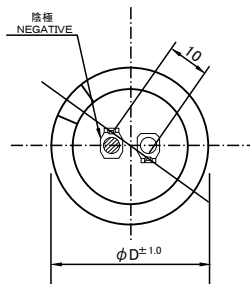
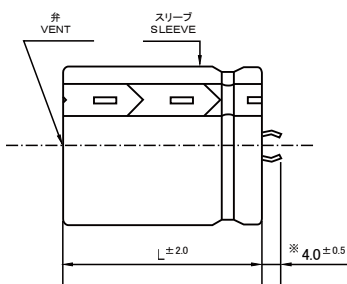

◆端子形状/Terminal Type

●逆差し防止端子形状(Keying terminal type)

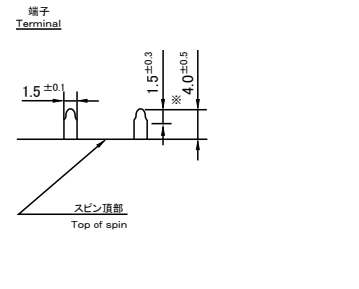
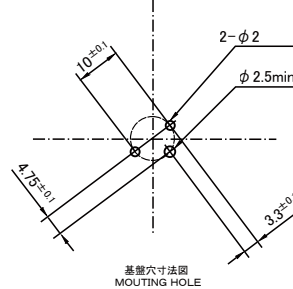
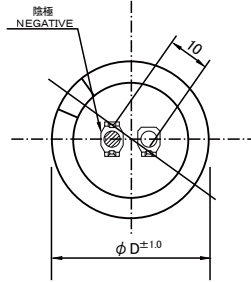
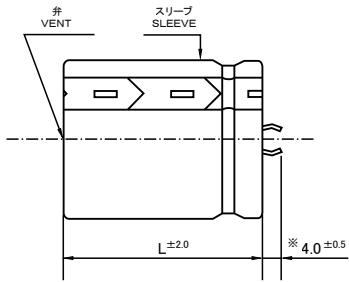

端子記号 Terminal Code	EN
-----------------------	----

端子材料 Terminal Material	Fe/Cu/Sn
---------------------------	----------

●耐振・逆差し防止端子形状(Vibration proof terminal type)

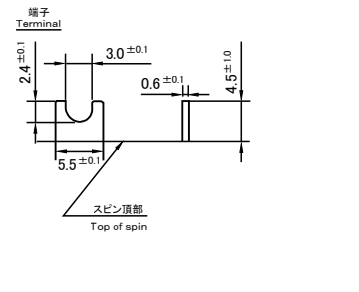
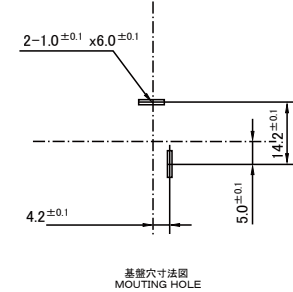
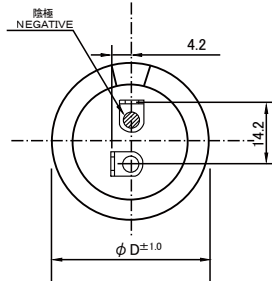
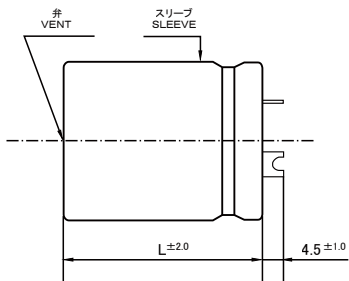

端子記号 Terminal Code	LN
-----------------------	----

端子材料 Terminal Material	Fe/Cu/Sn
---------------------------	----------

●多端子形状(4pin snap-in terminal type) 対象サイズφ 3.5 ~ φ 4.5

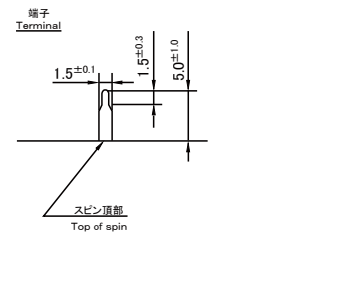
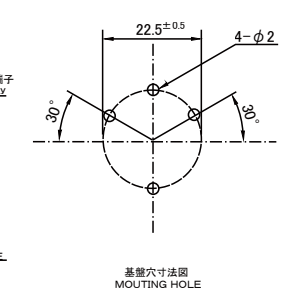
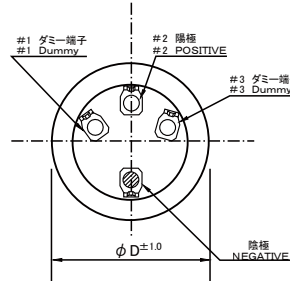
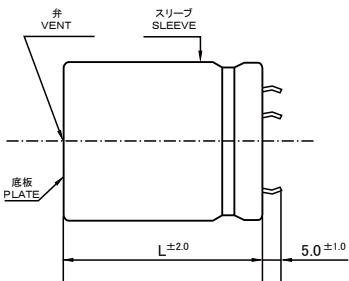

端子記号 Terminal Code	BN
-----------------------	----

端子材料 Terminal Material	Fe/Cu/Sn
---------------------------	----------

●横置き端子形状(Horizontal mount terminal type)

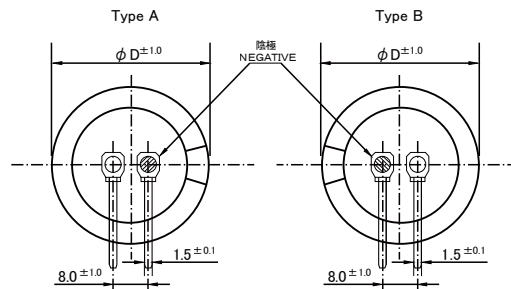
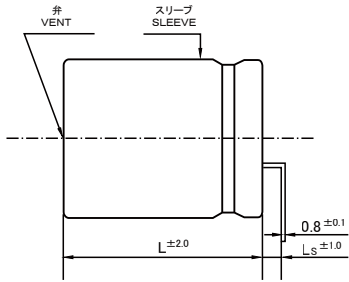

端子記号 Terminal Code	φ D	Ls	タイプ Type	タイプ Type
FA	φ 22 ~ φ 30	2.0 ± 0.5	A	標準極性 Standard polarity
FN	φ 20 ~ φ 25	4.0 ± 1.0		標準極性 Standard polarity
FB	φ 22 ~ φ 30	2.0 ± 0.5	B	反転極性 Inverted polarity
FR	φ 20 ~ φ 25	4.0 ± 1.0		反転極性 Inverted polarity

・記載以外の端子形状については、別途ご相談ください。
Please consult us about the other terminal type.

SGV series

105°C 2000~5000時間 標準品
Load Life : 105°C 2000~5000 hours, Standard



AEC-Q200



◆規格表 / SPECIFICATIONS

項目 Item	特性 Characteristics												
カテゴリ温度範囲 Category Temperature Range	-55 ~ +105°C	-40 ~ +105°C	-25 ~ +105°C										
定格電圧範囲 Rated Voltage Range	6.3~50Vdc	63,100Vdc	160~450Vdc										
静電容量許容差 Capacitance Tolerance	±20% (20°C, 120Hz)												
漏れ電流 Leakage Current (MAX)	6.3 ~ 100 Vdc	160 ~ 450 Vdc											
	I=0.01CV又は3µAのいずれか大なる値以下 (定格電圧印加2分後) I=0.01CV or 3µA whichever is greater. (After 2 minutes)	I=0.04CV+100µA以下(1分値) I=0.04CV+100µA (1minute) I=0.02CV+25µA以下(5分値) I=0.02CV+25µA (5minutes)											
I=漏れ電流 (µA) C=静電容量 (µF) V=定格電圧 (Vdc) Leakage Current Capacitance Rated Voltage													
損失角の正接(tanδ) Dissipation Factor(MAX)	定格電圧 (Vdc) Rated Voltage	6.3	10	16	25	35	50	63	100	160 ~250	400 450	(20°C, 120Hz)	
	φ6.3X8, φ8~φ18	0.35	0.26	0.24	0.18	0.14	0.12	0.12	0.10	0.15	0.20		
1000µFを越えるものは 1000µF増す毎に上表の値に0.02を加えた値とする。 When rated capacitance is over 1000µF, tanδ shall be added 0.02 to the listed value with increase of every 1000µF.													
耐久性 Endurance	105°C中で右表の時間定格電圧(リップル重畳)印加後、下記項目を満足すること。 After applying rated voltage with rated ripple current for specified time at 105°C, the capacitors shall meet the following requirements.												
	静電容量変化率 Capacitance Change	初期値の ±25% 以内 Within ±25% of the initial value.										定格電圧(Vdc) Rated Voltage	時間(hrs) Life Time
	損失角の正接 Dissipation Factor	規格値の 200% 以下 Not more than 200% of the specified value.										6.3~100	2000
	漏れ電流 Leakage Current	規格値以下 Not more than the specified value.										160~450	5000
低温特性 Low Temperature Stability (インピーダンス比) Impedance Ratio (MAX)	定格電圧 (Vdc) Rated Voltage	6.3	10	16	25	35	50	63	100	160 ~250	400 450	(120Hz)	
	Z(-20°C) / Z(20°C)	4	3	2	2	2	2	2	2	3	6		
	Z(-40°C) / Z(20°C)	8	8	4	4	3	3	5	5	-	-		

◆呼称方法 / PART NUMBER

□□□ SGV □□□□ M □□□ D x L
 定格電圧 シリーズ名 静電容量 静電容量許容差 副記号 ケースサイズ
 Rated Voltage Series Capacitance Capacitance Tolerance Option Case Size

◆リップル電流補正係数 / MULTIPLIER FOR RIPPLE CURRENT

周波数 (Hz) Frequency	60(50)	120	500	1k	10k≤
2.2~6.8µF	0.65	1.00	1.20	1.30	1.50
8.2~68µF	0.80	1.00	1.20	1.30	1.50
100~1000µF	0.80	1.00	1.10	1.15	1.20
2200~6800µF	0.80	1.00	1.05	1.10	1.15

◆表示 / MARKING

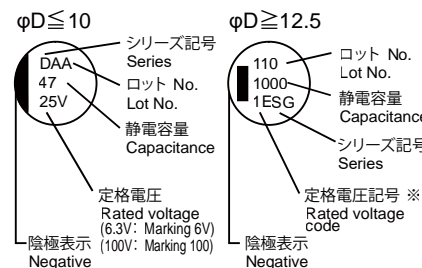

※電圧記号 Voltage code

定格電圧(Vdc) Rated Voltage	6.3	10	16	25
電圧記号 Voltage code	0J	1A	1C	1E
定格電圧(Vdc) Rated Voltage	35	50	63	100
電圧記号 Voltage code	1V	1H	1J	2A
定格電圧(Vdc) Rated Voltage	160	200	250	400
電圧記号 Voltage code	2C	2D	2E	2G
定格電圧(Vdc) Rated Voltage	450			
電圧記号 Voltage code	2W			

◆寸法図／DIMENSIONS

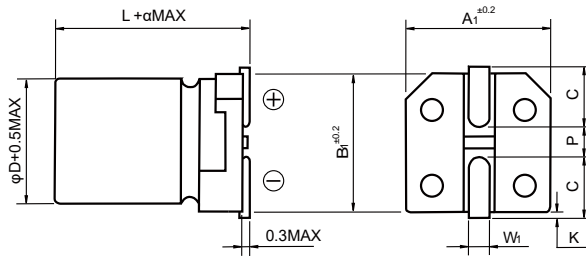

φD	L	A1	B1	C	W1	P	K	α
6.3	8	6.6	6.6	2.7	0.5~0.8	1.8	0.5MAX	0
8	6.5	8.3	8.3	3.4	0.5~0.8	2.2	0.5MAX	0
8	10.5	8.3	8.3	2.9	0.8~1.1	3.1	0.5MAX	※
10	10.5	10.3	10.3	3.2	0.8~1.1	4.5	0.5MAX	※
12.5	13.5	13	13	4.9	0.8~1.1	4.5	0.7±0.4	0.5
12.5	16	13	13	4.9	0.8~1.1	4.5	0.7±0.4	0.5
16	16.5	17	17	6	1.0~1.6	6.8	0.7±0.4	0.5
16	21.5	17	17	6	1.0~1.6	6.8	0.7±0.4	0.5
18	16.5	19	19	7	1.0~1.6	6.8	0.7±0.4	0.5
18	21.5	19	19	7	1.0~1.6	6.8	0.7±0.4	0.5

※ 6.3~100V品 : α=0 160~400V品 : α=0.2

◆標準品一覧表／STANDARD SIZE

Size φD×L(mm), Rated Ripple Current (mA r.m.s./105℃, 120Hz)

Vdc	Cap (μF)	Size (φD×L)	Ripple
6.3	220	6.3×8	121
	470	8×10.5	210
	1000	10×10.5	495
		12.5×13.5	
	2200	12.5×16	750
	3300	16×21.5	930
		18×16.5	
	4700	18×21.5	1200
6800	18×21.5	1350	
10	330	8×10.5	195
	470	8×10.5	210
		10×10.5	440
	1000	12.5×16	500
	2200	16×16.5	810
	3300	16×21.5	1000
18×16.5			
4700	18×21.5	1200	
16	100	6.3×8	111
	220	8×10.5	185
	330	8×10.5	290
		10×10.5	440
	470	8×10.5	320
		10×10.5	460
	1000	16×16.5	630
	2200	16×21.5	930
		18×16.5	
	3300	18×21.5	1150
25	47	6.3×8	79
	100	8×10.5	180
	220	8×10.5	320
		10×10.5	355
	330	10×10.5	450
		12.5×13.5	
	470	10×10.5	490
	1000	16×21.5	700
		18×16.5	
	2200	18×21.5	1050
3300	18×21.5	1700	

Vdc	Cap (μF)	Size (φD×L)	Ripple
35	33	6.3×8	76
	100	8×10.5	180
		10×10.5	305
	220	10×10.5	450
		12.5×13.5	
	330	12.5×16	460
	470	16×16.5	490
	1000	16×21.5	750
18×16.5			
50	22	6.3×8	67
	33	8×10.5	140
	47	8×10.5	167
		10×10.5	180
	100	8×10.5	230
		10×10.5	315
	220	12.5×16	380
	330	16×16.5	470
	470	16×21.5	550
		18×16.5	
1000	18×21.5	820	
63	22	8×10.5	55
	33	8×10.5	11
	47	8×10.5	120
	100	12.5×16	225
	220	16×16.5	385
	330	16×21.5	490
		18×16.5	
	470	18×21.5	590
100	10	8×10.5	65
	22	10×10.5	90
	33	10×10.5	135
	47	12.5×13.5	160
	100	16×16.5	285
	220	16×21.5	440
		18×16.5	

Vdc	Cap (μF)	Size (φD×L)	Ripple
160	12	8×10.5	115
	22	10×10.5	150
	39	12.5×13.5	250
	47	12.5×16	310
	68	16×16.5	400
	100	18×16.5	480
	120	16×21.5	560
	150	18×21.5	690
200	10	8×10.5	100
	15	10×10.5	130
	33	12.5×13.5	230
	42	12.5×16	270
	56	16×16.5	350
	68	18×16.5	440
	100	16×21.5	500
	120	18×21.5	620
250	6.8	8×10.5	85
	12	10×10.5	115
	22	12.5×13.5	190
	33	12.5×16	240
	47	16×16.5	320
	56	18×16.5	400
	68	16×21.5	450
	100	18×21.5	560
400	2.7	8×10.5	45
	4.7	10×10.5	75
	10	12.5×13.5	135
	12	12.5×16	165
	18	16×16.5	220
	22	18×16.5	280
	33	16×21.5	320
	47	18×21.5	400
450	6.8	12.5×13.5	110
	8.2	12.5×16	150
	12	16×16.5	195
	18	18×16.5	245
	22	16×21.5	275
	27	18×21.5	345

TAV series

125°C 2000~4000時間保証品 低ESR品
Load Life 125°C 2000~4000 hours, Low ESR

AEC-Q200

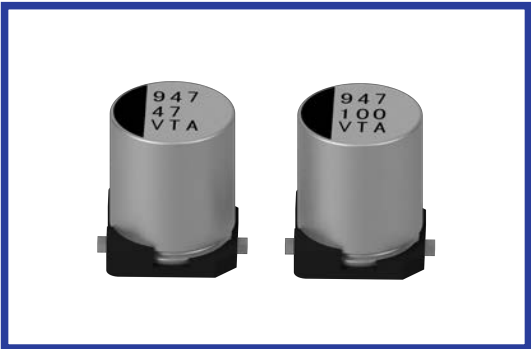

◆規格表/SPECIFICATIONS

項目 Item	特性 Characteristics	
カテゴリ温度範囲 Category Temperature Range	-40~+125°C	
定格電圧範囲 Rated Voltage Range	35Vdc	
静電容量許容差 Capacitance Tolerance	±20% (20°C, 120Hz)	
漏れ電流 Leakage Current (MAX)	I=0.01CV 又は 3μA のいずれか大なる値以下 (定格電圧印加2分後) I=0.01CV or 3μA whichever is greater. (After 2 minutes) I=漏れ電流(μA) C=静電容量(μF) V=定格電圧(Vdc) Leakage Current Capacitance Rated Voltage	
損失角の正接 (tan δ) Dissipation Factor(MAX)	定格電圧 (Vdc) Rated Voltage	35 (20°C, 120Hz)
	φ 6.3	0.16
	φ 8~10	0.14
耐久性 Endurance	125°C中で表の時間定格電圧印加後、下記項目を満足すること After applying rated voltage for specified time at 125°C, the capacitors shall meet the following Criteria.	
	静電容量変化率 Capacitance Change	初期値の±30%以内 Within ±30% of the initial value.
	損失角の正接 Dissipation Factor	規格値の300%以下 Not more than 300% of the specified value.
	漏れ電流 Leakage Current	規格値以下 Not more than the specified value.
ケースサイズ Case Size	φ D=6.3	φ D=8,10
時間(hrs) Life Time	2000	4000
低温特性 Low Temperature Stability (インピーダンス比) Impedance Ratio (MAX)	定格電圧 (Vdc) Rated Voltage	35 (120Hz)
	Z(-40°C) / Z(20°C)	3

◆寸法図/DIMENSIONS

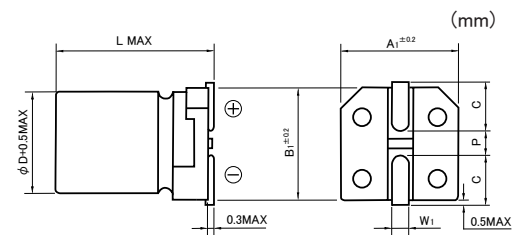

φ D	L	A1	B1	C	W1	P
6.3	8	6.6	6.6	2.7	0.5~0.8	1.8
8	10.5	8.3	8.3	2.9	0.8~1.1	3.1
10	10.5	10.3	10.3	3.2	0.8~1.1	4.5

◆表示/MARKING

※電圧記号 Voltage code

定格電圧 (Vdc) Rated Voltage	35
電圧記号 Voltage code	V

陰極表示 Negative

◆リップル電流補正係数/
MULTIPLIER FOR RIPPLE CURRENT

周波数 (Hz) Frequency	120	1k	10k	100k≤
47~100 μF	0.40	0.75	0.90	1.00
220~330 μF	0.50	0.80	0.94	1.00

◆呼称方法/PART NUMBER

□□□	TAV	□□□□□	M	□□□	D x L
定格電圧 Rated Voltage	シリーズ名 Series	静電容量 Capacitance	静電容量許容差 Capacitance Tolerance	副記号 Option	ケースサイズ Case Size

◆標準品一覧表/STANDARD SIZE

Size φ D x L (mm), Rated Ripple Current (mA r.m.s./125°C, 100kHz), ESR(Ω MAX/20°C, 100kHz)

Vdc	Cap (μF)	Size (φ D x L)	Ripple	ESR	
				Initial	After 125°C 2000hrs
35	47	6.3x8	240	0.3	0.5
	100	6.3x8	240	0.3	0.5
	220	8x10.5	500	0.15	-
	330	10x10.5	800	0.12	-

TGV series

125°C 3000~5000時間 低ESR品
Load Life : 125°C 3000~5000 hours, Low ESR
耐久試験後ESR規格規定品。(φ8・φ10)
ESR standard after endurance test.(φ8・φ10)
AEC-Q200

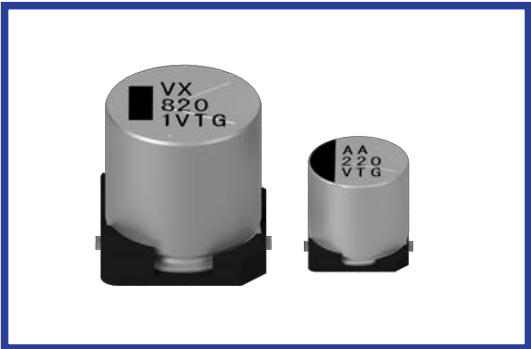

◆規格表/SPECIFICATIONS

項目 Item	特性 Characteristics																																			
カテゴリ温度範囲 Category Temperature Range	-40~+125°C																																			
定格電圧範囲 Rated Voltage Range	16~80Vdc																																			
静電容量許容差 Capacitance Tolerance	±20%(20°C, 120Hz)																																			
漏れ電流 Leakage Current (MAX)	I=0.01CV又は3μAのいずれか大なる値以下(定格電圧印加2分後) I=0.01CV or 3μA whichever is greater. (After 2 minutes) I=漏れ電流(μA) C=静電容量(μF) V=定格電圧(Vdc) Leakage Current Capacitance Rated Voltage																																			
損失角の正接(tan δ) Dissipation Factor(MAX)	<table border="1"> <tr> <td>定格電圧 (Vdc) Rated Voltage</td> <td>16</td> <td>25</td> <td>35</td> <td>50</td> <td>63</td> <td>80</td> <td>(20°C, 120Hz)</td> </tr> <tr> <td>φ8~10</td> <td>0.23</td> <td>0.18</td> <td>0.16</td> <td>0.14</td> <td>-</td> <td>-</td> <td></td> </tr> <tr> <td>φ12.5~18</td> <td>0.18</td> <td>0.16</td> <td>0.14</td> <td>0.12</td> <td>0.14</td> <td>0.12</td> <td></td> </tr> </table> <p>1000μFを越えるものは1000μF増す毎に上表の値に0.02を加えた値とする。 When rated capacitance is over 1000μF, tan δ shall be added 0.02 to the listed value with increase of every 1000μF.</p>	定格電圧 (Vdc) Rated Voltage	16	25	35	50	63	80	(20°C, 120Hz)	φ8~10	0.23	0.18	0.16	0.14	-	-		φ12.5~18	0.18	0.16	0.14	0.12	0.14	0.12												
定格電圧 (Vdc) Rated Voltage	16	25	35	50	63	80	(20°C, 120Hz)																													
φ8~10	0.23	0.18	0.16	0.14	-	-																														
φ12.5~18	0.18	0.16	0.14	0.12	0.14	0.12																														
耐久性 Endurance	<p>125°C中で右表の時間定格電圧印加後、下記項目を満足すること。 After applying rated voltage for specified time at 125°C, the capacitors shall meet the following requirements.</p> <table border="1"> <tr> <td>静電容量変化率 Capacitance Change</td> <td>初期値の ±30% 以内 Within ±30% of the initial value.</td> <td rowspan="4"> <table border="1"> <tr> <td>ケースサイズ Case Size</td> <td colspan="2">時間(hrs) Life Time</td> </tr> <tr> <td></td> <td>6.3~50Vdc</td> <td>63,80Vdc</td> </tr> <tr> <td>φD ≤ 10</td> <td>3000</td> <td>-</td> </tr> <tr> <td>φD = 12.5</td> <td rowspan="2">5000</td> <td>3000</td> </tr> <tr> <td>φD ≥ 16</td> <td>4000</td> </tr> </table> </td> </tr> <tr> <td>損失角の正接 Dissipation Factor</td> <td>規格値の 300% 以下 Not more than 300% of the specified value.</td> </tr> <tr> <td>漏れ電流 Leakage Current</td> <td>規格値以下 Not more than the specified value.</td> </tr> <tr> <td></td> <td> <p>耐久性試験後(125°C定格電圧印加2000時間後)ESR ESR standard after endurance test (125°C, 2000 hrs with rated voltage applied)</p> <table border="1"> <tr> <td></td> <td colspan="2">16~35Vdc</td> </tr> <tr> <td></td> <td>8 × 10.5</td> <td>10 × 10.5</td> </tr> <tr> <td>20°C</td> <td>0.6</td> <td>0.4</td> </tr> <tr> <td>-40°C</td> <td>4.5</td> <td>3.5</td> </tr> </table> </td> </tr> </table>	静電容量変化率 Capacitance Change	初期値の ±30% 以内 Within ±30% of the initial value.	<table border="1"> <tr> <td>ケースサイズ Case Size</td> <td colspan="2">時間(hrs) Life Time</td> </tr> <tr> <td></td> <td>6.3~50Vdc</td> <td>63,80Vdc</td> </tr> <tr> <td>φD ≤ 10</td> <td>3000</td> <td>-</td> </tr> <tr> <td>φD = 12.5</td> <td rowspan="2">5000</td> <td>3000</td> </tr> <tr> <td>φD ≥ 16</td> <td>4000</td> </tr> </table>	ケースサイズ Case Size	時間(hrs) Life Time			6.3~50Vdc	63,80Vdc	φD ≤ 10	3000	-	φD = 12.5	5000	3000	φD ≥ 16	4000	損失角の正接 Dissipation Factor	規格値の 300% 以下 Not more than 300% of the specified value.	漏れ電流 Leakage Current	規格値以下 Not more than the specified value.		<p>耐久性試験後(125°C定格電圧印加2000時間後)ESR ESR standard after endurance test (125°C, 2000 hrs with rated voltage applied)</p> <table border="1"> <tr> <td></td> <td colspan="2">16~35Vdc</td> </tr> <tr> <td></td> <td>8 × 10.5</td> <td>10 × 10.5</td> </tr> <tr> <td>20°C</td> <td>0.6</td> <td>0.4</td> </tr> <tr> <td>-40°C</td> <td>4.5</td> <td>3.5</td> </tr> </table>		16~35Vdc			8 × 10.5	10 × 10.5	20°C	0.6	0.4	-40°C	4.5	3.5
静電容量変化率 Capacitance Change	初期値の ±30% 以内 Within ±30% of the initial value.	<table border="1"> <tr> <td>ケースサイズ Case Size</td> <td colspan="2">時間(hrs) Life Time</td> </tr> <tr> <td></td> <td>6.3~50Vdc</td> <td>63,80Vdc</td> </tr> <tr> <td>φD ≤ 10</td> <td>3000</td> <td>-</td> </tr> <tr> <td>φD = 12.5</td> <td rowspan="2">5000</td> <td>3000</td> </tr> <tr> <td>φD ≥ 16</td> <td>4000</td> </tr> </table>	ケースサイズ Case Size		時間(hrs) Life Time			6.3~50Vdc	63,80Vdc	φD ≤ 10	3000	-	φD = 12.5	5000		3000	φD ≥ 16	4000																		
ケースサイズ Case Size	時間(hrs) Life Time																																			
	6.3~50Vdc		63,80Vdc																																	
φD ≤ 10	3000		-																																	
φD = 12.5	5000	3000																																		
φD ≥ 16		4000																																		
損失角の正接 Dissipation Factor	規格値の 300% 以下 Not more than 300% of the specified value.																																			
漏れ電流 Leakage Current	規格値以下 Not more than the specified value.																																			
	<p>耐久性試験後(125°C定格電圧印加2000時間後)ESR ESR standard after endurance test (125°C, 2000 hrs with rated voltage applied)</p> <table border="1"> <tr> <td></td> <td colspan="2">16~35Vdc</td> </tr> <tr> <td></td> <td>8 × 10.5</td> <td>10 × 10.5</td> </tr> <tr> <td>20°C</td> <td>0.6</td> <td>0.4</td> </tr> <tr> <td>-40°C</td> <td>4.5</td> <td>3.5</td> </tr> </table>		16~35Vdc			8 × 10.5	10 × 10.5	20°C	0.6	0.4	-40°C	4.5	3.5																							
	16~35Vdc																																			
	8 × 10.5	10 × 10.5																																		
20°C	0.6	0.4																																		
-40°C	4.5	3.5																																		
低温特性 Low Temperature Stability (インピーダンス比) Impedance Ratio (MAX)	<table border="1"> <tr> <td>定格電圧 (Vdc) Rated Voltage</td> <td>16</td> <td>25</td> <td>35</td> <td>50</td> <td>63</td> <td>80</td> <td>(120Hz)</td> </tr> <tr> <td>Z(-40°C)/Z(20°C)</td> <td>3</td> <td>3</td> <td>3</td> <td>3</td> <td>3</td> <td>3</td> <td></td> </tr> </table>	定格電圧 (Vdc) Rated Voltage	16	25	35	50	63	80	(120Hz)	Z(-40°C)/Z(20°C)	3	3	3	3	3	3																				
定格電圧 (Vdc) Rated Voltage	16	25	35	50	63	80	(120Hz)																													
Z(-40°C)/Z(20°C)	3	3	3	3	3	3																														

◆呼称方法/PART NUMBER

□□□ TGV □□□□□ M □□□ D x L
 定格電圧 シリーズ名 静電容量 静電容量許容差 副記号 ケースサイズ
 Rated Voltage Series Capacitance Capacitance Tolerance Option Case Size

◆リップル電流補正係数/
MULTIPLIER FOR RIPPLE CURRENT

周波数 (Hz) Frequency	120	1k	10k	100k ≤
33 μF	0.45	0.75	0.90	1.00
47~100 μF	0.50	0.80	0.95	1.00
220~3300 μF	0.60	0.85	0.95	1.00

◆表示/MARKING

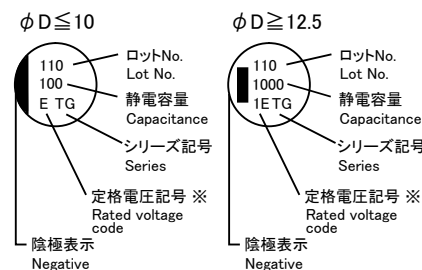

※電圧記号 Voltage code

定格電圧(Vdc) Rated Voltage	16	25	35
記号 code	φD ≤ 10 C E V	φD ≥ 12.5 1C 1E 1V	
定格電圧(Vdc) Rated Voltage	50	63	80
記号 code	φD ≤ 10 H - -	φD ≥ 12.5 1H 1J 1K	

◆寸法図／DIMENSIONS

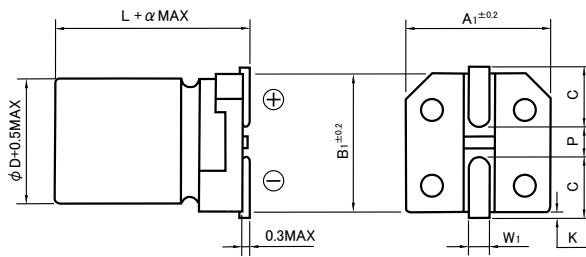

(mm)

ϕD	L	A1	B1	C	W1	P	K	α
8	10.5	8.3	8.3	2.9	0.8~1.1	3.1	0.5MAX	0
10	10.5	10.3	10.3	3.2	0.8~1.1	4.5	0.5MAX	0
12.5	13.5	13	13	4.9	0.8~1.1	4.5	0.7±0.4	0.5
12.5	16	13	13	4.9	0.8~1.1	4.5	0.7±0.4	0.5
16	16.5	17	17	6	1.0~1.6	6.8	0.7±0.4	0.5
16	21.5	17	17	6	1.0~1.6	6.8	0.7±0.4	0.5
18	16.5	19	19	7	1.0~1.6	6.8	0.7±0.4	0.5
18	21.5	19	19	7	1.0~1.6	6.8	0.7±0.4	0.5

◆標準品一覧表／STANDARD SIZE

Size $\phi D \times L$ (mm), Rated Ripple Current (mA r.m.s./125°C, 100kHz), ESR(Ω MAX/100kHz)

Vdc	Cap (μF)	Size ($\phi D \times L$)	Ripple	ESR	
				20°C	-40°C
16	100	8×10.5	350	0.150	3.0
	220	8×10.5	350	0.150	3.0
	330	10×10.5	550	0.120	2.0
	470	10×10.5	550	0.120	2.0
	820	12.5×13.5	850	0.092	1.1
	1000	12.5×16	1000	0.074	0.9
	1500	16×16.5	1200	0.066	0.7
	1800	18×16.5	1300	0.064	0.6
	2200	16×21.5	1650	0.041	0.4
	3300	18×21.5	1800	0.039	0.3
25	100	8×10.5	350	0.150	3.0
	220	8×10.5	350	0.150	3.0
		10×10.5	550	0.120	2.0
	330	10×10.5	550	0.120	2.0
	680	12.5×13.5	850	0.092	1.1
	820	12.5×16	1000	0.074	0.9
	1200	16×16.5	1200	0.066	0.7
	1500	18×16.5	1300	0.064	0.6
	2200	16×21.5	1650	0.041	0.4
	2700	18×21.5	1800	0.039	0.3
35	47	8×10.5	350	0.150	3.0
	100	8×10.5	350	0.150	3.0
		10×10.5	550	0.120	2.0
	220	10×10.5	550	0.120	2.0
	470	12.5×13.5	850	0.092	1.1
	560	12.5×16	1000	0.074	0.9
	820	16×16.5	1200	0.066	0.7
	1000	18×16.5	1300	0.064	0.6
	1500	16×21.5	1650	0.041	0.4
1800	18×21.5	1800	0.039	0.3	

Vdc	Cap (μF)	Size ($\phi D \times L$)	Ripple	ESR	
				20°C	-40°C
50	33	8×10.5	300	0.340	6.7
	47	8×10.5	300	0.340	6.7
		10×10.5	500	0.220	4.4
	100	10×10.5	500	0.220	4.4
	360	12.5×16	900	0.150	3.0
	510	16×16.5	950	0.120	2.0
	680	18×16.5	1000	0.110	1.8
	820	16×21.5	1300	0.073	1.3
	1200	18×21.5	1450	0.066	1.1
	63	240	12.5×13.5	1090	0.140
330		12.5×16	1310	0.110	1.5
430		16×16.5	1460	0.086	1.2
560		18×16.5	1550	0.081	0.86
680		16×21.5	2020	0.053	0.68
910		18×21.5	2140	0.050	0.53
80	180	12.5×13.5	970	0.170	2.5
	240	12.5×16	1160	0.130	1.8
	270	16×16.5	1300	0.098	1.3
	360	18×16.5	1390	0.091	0.98
	430	16×21.5	1810	0.063	0.80
	560	18×21.5	1920	0.059	0.59

THV series

125°C 2000~3000時間 低ESR品
Load Life : 125°C 2000~3000 hours, Low ESR

AEC-Q200



◆規格表 / SPECIFICATIONS

項目 Item	特性 Characteristics					
カテゴリ温度範囲 Category Temperature Range	-40~+125°C					
定格電圧範囲 Rated Voltage Range	16~50Vdc					
静電容量許容差 Capacitance Tolerance	±20% (20°C, 120Hz)					
漏れ電流 Leakage Current (MAX)	I=0.01CV 又は 3μA のいずれか大なる値以下 (定格電圧印加2分後) I=0.01CV or 3μA whichever is greater. (After 2 minutes) I=漏れ電流(μA) C=静電容量(μF) V=定格電圧(Vdc) Leakage Current Capacitance Rated Voltage					
損失角の正接 (tan δ) Dissipation Factor(MAX)	定格電圧 (Vdc) Rated Voltage	16	25	35	50	(20°C, 120Hz)
	tan δ	0.23	0.18	0.16	0.14	
耐久性 Endurance	125°C中で表の時間定格電圧(リプル重量)印加後、下記項目を満足すること。 After applying rated voltage with rated ripple current for specified time at 125°C, the capacitors shall meet the following requirements.					
	静電容量変化率 Capacitance Change	初期値の±30%以内 Within ±30% of the initial value.				
	損失角の正接 Dissipation Factor	規格値の300%以下 Not more than 300% of the specified value.				
	漏れ電流 Leakage Current	規格値以下 Not more than the specified value.				
	ケースサイズ Case Size	時間 (hrs) LifeTime				
	φD=6.3	2000				
	φD≥8	3000				
低温特性 Low Temperature Stability (インピーダンス比) Impedance Ratio (MAX)	定格電圧 (Vdc) Rated Voltage	16	25	35	50	(120Hz)
	Z(-40°C) / Z(20°C)	4	4	3	3	

◆寸法図 / DIMENSIONS

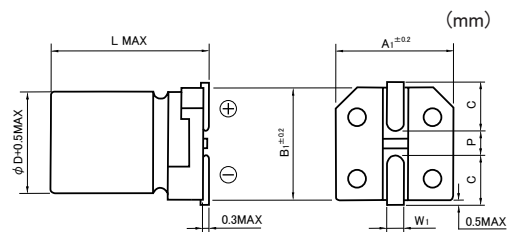

φD	L	A1	B1	C	W1	P
6.3	6.1	6.6	6.6	2.7	0.5~0.8	1.8
6.3	8	6.6	6.6	2.7	0.5~0.8	1.8
8	10.5	8.3	8.3	2.9	0.8~1.1	3.1
10	10.5	10.3	10.3	3.2	0.8~1.1	4.5

◆表示 / MARKING

※電圧記号 Voltage code

定格電圧(Vdc) Rated Voltage	16	25	35	50
電圧記号 Voltage code	C	E	V	H

陰極表示 Negative

◆リップル電流補正係数 / MULTIPLIER FOR RIPPLE CURRENT

周波数 (Hz) Frequency	120	1k	10k	100k≤
10~33 μF	0.45	0.75	0.90	1.00
47~100 μF	0.50	0.80	0.95	1.00
220~330 μF	0.60	0.85	0.95	1.00

◆呼称方法 / PART NUMBER

□□□ THV □□□□□ M □□□ D x L
 定格電圧 シリーズ名 静電容量 静電容量許容差 副記号 ケースサイズ
 Rated Voltage Series Capacitance Capacitance Tolerance Option Case Size

◆標準品一覧表 / STANDARD SIZE

Size φD x L(mm), Rated Ripple Current (mA r.m.s./125°C, 100kHz), ESR(Ω MAX/100kHz)

Vdc	Cap (μF)	Size (φD x L)	Ripple	ESR	
				20°C	-40°C
16	33	6.3x6.1	70	1	15
	47	6.3x8	200	0.7	10
		6.3x8	200	0.7	10
	100	8x10.5	300	0.3	4.5
		8x10.5	300	0.3	4.5
	10x10.5	500	0.2	3	
25	330	10x10.5	500	0.2	3
	33	6.3x6.1	70	1	15
	47	6.3x8	200	0.7	10
		8x10.5	300	0.3	4.5
100	8x10.5	300	0.3	4.5	

Vdc	Cap (μF)	Size (φD x L)	Ripple	ESR		
				20°C	-40°C	
25	220	8x10.5	300	0.3	4.5	
		10x10.5	500	0.2	3	
		10x10.5	500	0.2	3	
	22	6.3x8	200	0.7	10	
		33	6.3x6.1	70	1	15
			6.3x8	200	0.7	10
35	47	6.3x8	200	0.7	10	
		8x10.5	300	0.3	4.5	
	100	8x10.5	300	0.3	4.5	
		10x10.5	500	0.2	3	
220	10x10.5	500	0.2	3		

Vdc	Cap (μF)	Size (φD x L)	Ripple	ESR	
				20°C	-40°C
50	10	6.3x6.1	70	1	15
	22	6.3x8	150	0.9	10
		6.3x8	150	0.9	10
	33	8x10.5	250	0.36	4.5
		8x10.5	250	0.36	4.5
	47	10x10.5	350	0.25	3
100	10x10.5	350	0.25	3	

TKV series

105°C 2000時間 低ESR品
Load life : 105°C 2000 hours, Low ESR

AEC-Q200



◆規格表 / SPECIFICATIONS

項目 Item	特性 Characteristics																												
カテゴリ温度範囲 Category Temperature Range	-55~+105°C																												
定格電圧範囲 Rated Voltage Range	6.3~35Vdc																												
静電容量許容差 Capacitance Tolerance	±20%(20°C, 120Hz)																												
漏れ電流 Leakage Current (MAX)	I=0.01CV又は3μAのいずれか大なる値以下(定格電圧印加2分後) I=0.01CV or 3μA whichever is greater. (After 2 minutes) I=漏れ電流(μA) C=静電容量(μF) V=定格電圧(Vdc) Leakage Current Capacitance Rated Voltage																												
損失角の正接(tan δ) Dissipation Factor(MAX)	<table border="1"> <tr> <td>定格電圧 (Vdc) Rated Voltage</td> <td>6.3</td> <td>10</td> <td>16</td> <td>25</td> <td>35</td> <td>(20°C, 120Hz)</td> </tr> <tr> <td>tan δ</td> <td>0.26</td> <td>0.19</td> <td>0.16</td> <td>0.14</td> <td>0.12</td> <td></td> </tr> </table>	定格電圧 (Vdc) Rated Voltage	6.3	10	16	25	35	(20°C, 120Hz)	tan δ	0.26	0.19	0.16	0.14	0.12															
定格電圧 (Vdc) Rated Voltage	6.3	10	16	25	35	(20°C, 120Hz)																							
tan δ	0.26	0.19	0.16	0.14	0.12																								
耐久性 Endurance	<p>105°C中で2000時間定格電圧印加後、下記項目を満足すること。 After applying rated voltage for 2000 hours at 105°C, the capacitors shall meet the following requirements.</p> <table border="1"> <tr> <td>静電容量変化率 Capacitance Change</td> <td>初期値の ±30% 以内 Within ±30% of the initial value.</td> </tr> <tr> <td>損失角の正接 Dissipation Factor</td> <td>規格値の 200% 以下 Not more than 200% of the specified value.</td> </tr> <tr> <td>漏れ電流 Leakage Current</td> <td>規格値以下 Not more than the specified value.</td> </tr> </table>	静電容量変化率 Capacitance Change	初期値の ±30% 以内 Within ±30% of the initial value.	損失角の正接 Dissipation Factor	規格値の 200% 以下 Not more than 200% of the specified value.	漏れ電流 Leakage Current	規格値以下 Not more than the specified value.																						
静電容量変化率 Capacitance Change	初期値の ±30% 以内 Within ±30% of the initial value.																												
損失角の正接 Dissipation Factor	規格値の 200% 以下 Not more than 200% of the specified value.																												
漏れ電流 Leakage Current	規格値以下 Not more than the specified value.																												
低温特性 Low Temperature Stability (インピーダンス比) Impedance Ratio (MAX)	<table border="1"> <tr> <td>定格電圧 (Vdc) Rated Voltage</td> <td>6.3</td> <td>10</td> <td>16</td> <td>25</td> <td>35</td> <td>(120Hz)</td> </tr> <tr> <td>Z(-25°C)/Z(20°C)</td> <td>2</td> <td>2</td> <td>2</td> <td>2</td> <td>2</td> <td></td> </tr> <tr> <td>Z(-40°C)/Z(20°C)</td> <td>3</td> <td>3</td> <td>3</td> <td>3</td> <td>3</td> <td></td> </tr> <tr> <td>Z(-55°C)/Z(20°C)</td> <td>4</td> <td>4</td> <td>4</td> <td>3</td> <td>3</td> <td></td> </tr> </table>	定格電圧 (Vdc) Rated Voltage	6.3	10	16	25	35	(120Hz)	Z(-25°C)/Z(20°C)	2	2	2	2	2		Z(-40°C)/Z(20°C)	3	3	3	3	3		Z(-55°C)/Z(20°C)	4	4	4	3	3	
定格電圧 (Vdc) Rated Voltage	6.3	10	16	25	35	(120Hz)																							
Z(-25°C)/Z(20°C)	2	2	2	2	2																								
Z(-40°C)/Z(20°C)	3	3	3	3	3																								
Z(-55°C)/Z(20°C)	4	4	4	3	3																								

◆呼称方法 / PART NUMBER

□□□	TKV	□□□□□	M	□□□	D x L
定格電圧 Rated Voltage	シリーズ名 Series	静電容量 Capacitance	静電容量許容差 Capacitance Tolerance	副記号 Option	ケースサイズ Case Size

◆リップル電流補正係数 / MULTIPLIER FOR RIPPLE CURRENT

周波数 (Hz) Frequency	120	1k	10k	100k ≤
33 μF	0.42	0.75	0.90	1.00
47~150 μF	0.44	0.80	0.95	1.00
220~1800 μF	0.60	0.85	0.95	1.00

◆表示 / MARKING

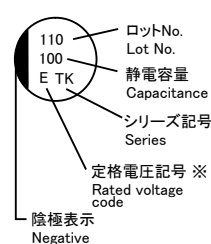

※電圧記号 Voltage code

定格電圧 (Vdc) Rated Voltage	6.3	10	16	25	35
電圧記号 Voltage code	j	A	C	E	V

◆寸法図／DIMENSIONS

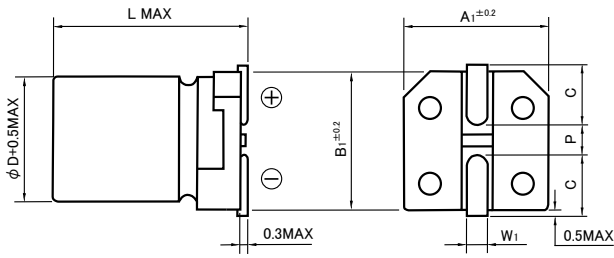

(mm)

φD	L	A1	B1	C	W1	P
6.3	6.1	6.6	6.6	2.7	0.5~0.8	1.8
6.3	8	6.6	6.6	2.7	0.5~0.8	1.8
8	10.5	8.3	8.3	2.9	0.8~1.1	3.1
10	10.5	10.3	10.3	3.2	0.8~1.1	4.5

◆標準品一覧表／STANDARD SIZE

Size φD×L(mm), Rated Ripple Current(mA r.m.s./105°C,100kHz), ESR(Ω MAX/20°C, 100kHz)

Vdc	Cap (μF)	Size (φD×L)	Ripple	ESR
6.3	100	6.3×6.1	300	0.26
	220	6.3×6.1	300	0.26
	330	6.3×8	600	0.16
	470	8×10.5	850	0.08
	1000	8×10.5	850	0.08
	1500	10×10.5	1190	0.06
	1800	10×10.5	850	0.08
10	150	6.3×6.1	300	0.26
	220	6.3×8	600	0.16
	330	8×10.5	850	0.08
	470	8×10.5	850	0.08
	680	8×10.5	850	0.08
	1000	10×10.5	1190	0.06
	1200	10×10.5	850	0.08
16	47	6.3×6.1	300	0.26
	100	6.3×6.1	300	0.26
		6.3×8	600	0.16
	220	6.3×8	600	0.16
	330	8×10.5	850	0.08
	470	8×10.5	850	0.08
	680	10×10.5	1190	0.06
	820	10×10.5	850	0.08

Vdc	Cap (μF)	Size (φD×L)	Ripple	ESR
25	33	6.3×6.1	300	0.26
	68	6.3×6.1	300	0.26
	100	6.3×8	600	0.16
	150	8×10.5	850	0.08
	220	8×10.5	850	0.08
	330	8×10.5	850	0.08
	470	10×10.5	1190	0.06
	560	10×10.5	850	0.08
	35	33	6.3×6.1	300
47		6.3×6.1	300	0.26
68		6.3×8	600	0.16
100		6.3×8	600	0.16
		8×10.5	850	0.08
150		8×10.5	850	0.08
220		8×10.5	850	0.08
330		10×10.5	1190	0.06
390		10×10.5	850	0.08

TLV series

105°C 2000~5000時間 低インピーダンス品
Load life : 105°C 2000~5000 hours, Low Impedance



AEC-Q200



◆規格表/SPECIFICATIONS

項目 Item	特性 Characteristics																																												
カテゴリ温度範囲 Category Temperature Range	-55~+105°C																																												
定格電圧範囲 Rated Voltage Range	6.3~100Vdc																																												
静電容量許容差 Capacitance Tolerance	±20%(20°C, 120Hz)																																												
漏れ電流 Leakage Current (MAX)	I=0.01CV又は3μAのいずれか大なる値以下(定格電圧印加2分後) I=0.01CV or 3μA whichever is greater. (After 2 minutes) I=漏れ電流(μA) C=静電容量(μF) V=定格電圧(Vdc) Leakage Current Capacitance Rated Voltage																																												
損失角の正接(tan δ) Dissipation Factor(MAX)	<table border="1"> <tr> <td>定格電圧 (Vdc) Rated Voltage</td> <td>6.3</td> <td>10</td> <td>16</td> <td>25</td> <td>35</td> <td>50</td> <td>63</td> <td>80</td> <td>100</td> <td>(20°C, 120Hz)</td> </tr> <tr> <td>tan δ</td> <td>0.26</td> <td>0.19</td> <td>0.16</td> <td>0.14</td> <td>0.12</td> <td>0.10</td> <td>0.09</td> <td>0.09</td> <td>0.08</td> <td></td> </tr> </table> <p>1000μFを越えるものは1000μF増す毎に上表の値に0.02を加えた値とする。 When rated capacitance is over 1000μF, tan δ shall be added 0.02 to the listed value with increase of every 1000μF.</p>	定格電圧 (Vdc) Rated Voltage	6.3	10	16	25	35	50	63	80	100	(20°C, 120Hz)	tan δ	0.26	0.19	0.16	0.14	0.12	0.10	0.09	0.09	0.08																							
定格電圧 (Vdc) Rated Voltage	6.3	10	16	25	35	50	63	80	100	(20°C, 120Hz)																																			
tan δ	0.26	0.19	0.16	0.14	0.12	0.10	0.09	0.09	0.08																																				
耐久性 Endurance	<p>105°C中で右表の時間定格電圧印加後、下記項目を満足すること。 After applying rated voltage for specified time at 105°C, the capacitors shall meet the following requirements.</p> <table border="1"> <tr> <td>静電容量変化率 Capacitance Change</td> <td>初期値の ±30% 以内 Within ±30% of the initial value.</td> <td>ケースサイズ Case Size</td> <td colspan="3">時間(hrs) Life Time</td> </tr> <tr> <td>損失角の正接 Dissipation Factor</td> <td>規格値の 200% 以下 (φ8, φ10: 300%) Not more than 200% of the specified value.</td> <td>φD ≤ 10</td> <td>6.3~50Vdc</td> <td>63Vdc</td> <td>80,100Vdc</td> </tr> <tr> <td>漏れ電流 Leakage Current</td> <td>規格値以下 Not more than the specified value.</td> <td>φD ≥ 12.5</td> <td>5000</td> <td>2000</td> <td>3000</td> </tr> <tr> <td></td> <td></td> <td></td> <td colspan="3">5000</td> </tr> </table>	静電容量変化率 Capacitance Change	初期値の ±30% 以内 Within ±30% of the initial value.	ケースサイズ Case Size	時間(hrs) Life Time			損失角の正接 Dissipation Factor	規格値の 200% 以下 (φ8, φ10: 300%) Not more than 200% of the specified value.	φD ≤ 10	6.3~50Vdc	63Vdc	80,100Vdc	漏れ電流 Leakage Current	規格値以下 Not more than the specified value.	φD ≥ 12.5	5000	2000	3000				5000																						
静電容量変化率 Capacitance Change	初期値の ±30% 以内 Within ±30% of the initial value.	ケースサイズ Case Size	時間(hrs) Life Time																																										
損失角の正接 Dissipation Factor	規格値の 200% 以下 (φ8, φ10: 300%) Not more than 200% of the specified value.	φD ≤ 10	6.3~50Vdc	63Vdc	80,100Vdc																																								
漏れ電流 Leakage Current	規格値以下 Not more than the specified value.	φD ≥ 12.5	5000	2000	3000																																								
			5000																																										
低温特性 Low Temperature Stability (インピーダンス比) Impedance Ratio (MAX)	<table border="1"> <tr> <td>定格電圧 (Vdc) Rated Voltage</td> <td>6.3</td> <td>10</td> <td>16</td> <td>25</td> <td>35</td> <td>50</td> <td>63</td> <td>80</td> <td>100</td> <td>(120Hz)</td> </tr> <tr> <td>Z(-25°C)/Z(20°C)</td> <td>2</td> <td>2</td> <td>2</td> <td>2</td> <td>2</td> <td>2</td> <td>2</td> <td>2</td> <td>2</td> <td></td> </tr> <tr> <td>Z(-40°C)/Z(20°C)</td> <td>3</td> <td>3</td> <td>3</td> <td>3</td> <td>3</td> <td>3</td> <td>3</td> <td>3</td> <td>3</td> <td></td> </tr> <tr> <td>Z(-55°C)/Z(20°C)</td> <td>4</td> <td>4</td> <td>4</td> <td>3</td> <td>3</td> <td>3</td> <td>3</td> <td>3</td> <td>3</td> <td></td> </tr> </table>	定格電圧 (Vdc) Rated Voltage	6.3	10	16	25	35	50	63	80	100	(120Hz)	Z(-25°C)/Z(20°C)	2	2	2	2	2	2	2	2	2		Z(-40°C)/Z(20°C)	3	3	3	3	3	3	3	3	3		Z(-55°C)/Z(20°C)	4	4	4	3	3	3	3	3	3	
定格電圧 (Vdc) Rated Voltage	6.3	10	16	25	35	50	63	80	100	(120Hz)																																			
Z(-25°C)/Z(20°C)	2	2	2	2	2	2	2	2	2																																				
Z(-40°C)/Z(20°C)	3	3	3	3	3	3	3	3	3																																				
Z(-55°C)/Z(20°C)	4	4	4	3	3	3	3	3	3																																				

◆呼称方法/PART NUMBER



◆リップル電流補正係数/
MULTIPLIER FOR RIPPLE CURRENT

周波数 (Hz) Frequency	120	1k	10k	100k ≤
22~33 μF	0.45	0.75	0.90	1.00
47~200 μF	0.50	0.80	0.95	1.00
220~10000 μF	0.60	0.85	0.95	1.00

◆表示/MARKING

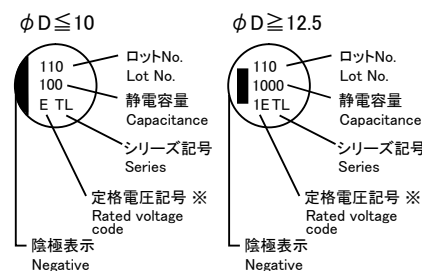

※電圧記号 Voltage code

定格電圧(Vdc) Rated Voltage	6.3	10	16	
記号 code	φD ≤ 10	j	A	C
	φD ≥ 12.5	0J	1A	1C
定格電圧(Vdc) Rated Voltage	25	35	50	
記号 code	φD ≤ 10	E	V	H
	φD ≥ 12.5	1E	1V	1H
定格電圧(Vdc) Rated Voltage	63	80	100	
記号 code	φD ≤ 10	J	K	2A
	φD ≥ 12.5	1J	1K	2A

◆寸法図／DIMENSIONS

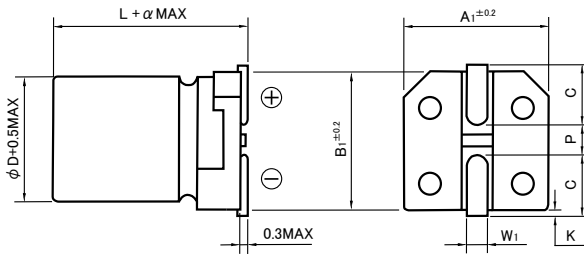

φD	L	A1	B1	C	W1	P	K	α
8	10.5	8.3	8.3	2.9	0.8~1.1	3.1	0.5MAX	0
10	10.5	10.3	10.3	3.2	0.8~1.1	4.5	0.5MAX	0
12.5	13.5	13	13	4.9	0.8~1.1	4.5	0.7±0.4	0.5
12.5	16	13	13	4.9	0.8~1.1	4.5	0.7±0.4	0.5
16	16.5	17	17	6	1.0~1.6	6.8	0.7±0.4	0.5
16	21.5	17	17	6	1.0~1.6	6.8	0.7±0.4	0.5
18	16.5	19	19	7	1.0~1.6	6.8	0.7±0.4	0.5
18	21.5	19	19	7	1.0~1.6	6.8	0.7±0.4	0.5

◆標準品一覧表／STANDARD SIZE

Size φD × L(mm), Rated Ripple Current(mA r.m.s./105°C,100kHz), Impedance(Ω MAX/20°C, 100kHz)

Vdc	Cap (μF)	Size (φD × L)	Ripple	Impedance
6.3	2200	12.5×13.5	1100	0.065
	3300	12.5×16	1400	0.055
	4700	16×16.5	1800	0.045
	6800	16×21.5	2330	0.029
	10000	18×21.5	2640	0.028
10	1000	10×10.5	850	0.08
	2200	12.5×16	1400	0.055
	3300	16×16.5	1800	0.045
	4700	18×16.5	2060	0.044
	6800	18×21.5	2640	0.028
16	470	8×10.5	600	0.16
	680	10×10.5	850	0.08
	1500	12.5×13.5	1100	0.065
	2200	16×16.5	1800	0.045
	3300	18×16.5	2060	0.044
25	4700	16×21.5	2330	0.029
	220	8×10.5	600	0.16
	330	8×10.5	600	0.16
	470	10×10.5	850	0.08
	1000	12.5×13.5	1100	0.065
35	1500	16×16.5	1800	0.045
	2200	18×16.5	2060	0.044
	3300	18×21.5	2640	0.028
	100	8×10.5	600	0.16
	150	8×10.5	600	0.16
	220	8×10.5	600	0.16
	330	10×10.5	850	0.08
	470	12.5×13.5	1100	0.065
50	680	12.5×13.5	1100	0.065
	1000	16×16.5	1800	0.045
	1500	18×16.5	2060	0.044
	2200	16×21.5	2330	0.029
	100	8×10.5	350	0.34
	150	10×10.5	670	0.18
	220	10×10.5	670	0.18
	330	12.5×13.5	900	0.12
	390	12.5×13.5	900	0.12
	470	12.5×16	1200	0.10
	560	16×16.5	1610	0.075
	680	16×16.5	1610	0.075
820	18×16.5	1700	0.07	
1000	18×16.5	1700	0.07	
1000	16×21.5	2000	0.05	
1300	16×21.5	2000	0.05	
1500	18×21.5	2200	0.045	

Vdc	Cap (μF)	Size (φD × L)	Ripple	Impedance
63	33	8×10.5	250	0.65
	47	8×10.5	250	0.65
	68	8×10.5	250	0.65
		10×10.5	400	0.35
	100	10×10.5	400	0.35
	150	12.5×13.5	800	0.17
	220	12.5×13.5	800	0.17
	330	12.5×16	1000	0.14
	470	16×16.5	1410	0.12
	680	18×16.5	1690	0.11
16×21.5		1790	0.08	
1000	18×21.5	1960	0.07	
80	22	8×10.5	200	0.80
	33	8×10.5	200	0.80
	47	10×10.5	300	0.51
	56	10×10.5	300	0.51
	68	12.5×13.5	740	0.28
	100	12.5×13.5	740	0.28
	180	12.5×13.5	740	0.28
	220	12.5×16	900	0.21
	330	16×16.5	1090	0.17
	470	18×16.5	1280	0.15
100	560	16×21.5	1580	0.11
	680	18×21.5	1690	0.091
	22	8×10.5	200	0.80
	33	10×10.5	300	0.51
	47	12.5×13.5	740	0.28
	100	16×16.5	1090	0.17
	110	12.5×13.5	740	0.28
	150	12.5×16	900	0.21
	200	16×16.5	1090	0.17
	220	18×16.5	1280	0.15
270	18×16.5	1280	0.15	
330	16×21.5	1580	0.11	
470	18×21.5	1690	0.091	

TNV series

105°C 3000~5000時間 低ESR品
Load Life : 105°C 3000~5000 hours, Low ESR

AEC-Q200



◆規格表/SPECIFICATIONS

項目 Item	特性 Characteristics						
カテゴリ温度範囲 Category Temperature Range	-55~+105°C						
定格電圧範囲 Rated Voltage Range	6.3~35Vdc						
静電容量許容差 Capacitance Tolerance	±20% (20°C, 120Hz)						
漏れ電流 Leakage Current (MAX)	I=0.01CV 又は 3μA のいずれか大なる値以下 (定格電圧印加2分後) I=0.01CV or 3μA whichever is greater. (After 2 minutes) I=漏れ電流(μA) C=静電容量(μF) V=定格電圧(Vdc) Leakage Current Capacitance Rated Voltage						
損失角の正接 (tan δ) Dissipation Factor(MAX)	定格電圧 (Vdc) Rated Voltage	6.3	10	16	25	35	(20°C, 120Hz)
	tan δ	0.26	0.19	0.16	0.14	0.12	
耐久性 Endurance	105°C中で表の時間定格電圧印加後、下記項目を満足すること。 After applying rated voltage for specified time at 105°C, the capacitors shall meet the following requirements.						
	静電容量変化率 Capacitance Change	初期値の±30%以内 Within ±30% of the initial value.					
	損失角の正接 Dissipation Factor	規格値の300%以下 Not more than 300% of the specified value.					
	漏れ電流 Leakage Current	規格値以下 Not more than the specified value.					
	定格電圧 (Vdc) Rated Voltage	6.3	10	16	25	35	時間 (hrs) LifeTime
							3000
							4000
	WV ≥ 16						5000
低温特性 Low Temperature Stability (インピーダンス比) Impedance Ratio (MAX)	定格電圧 (Vdc) Rated Voltage	6.3	10	16	25	35	(120Hz)
	Z(-25°C)/Z(20°C)	2	2	2	2	2	
	Z(-40°C)/Z(20°C)	3	3	3	3	3	
	Z(-55°C)/Z(20°C)	4	4	4	3	3	

◆寸法図/DIMENSIONS

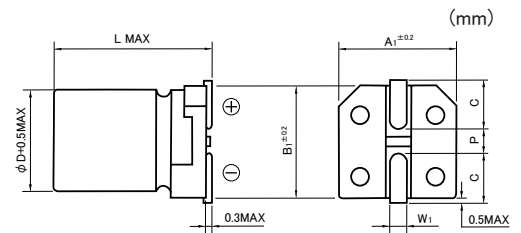

φD	L	A1	B1	C	W1	P
8	10.5	8.3	8.3	2.9	0.8~1.1	3.1
10	10.5	10.3	10.3	3.2	0.8~1.1	4.5

◆表示/MARKING

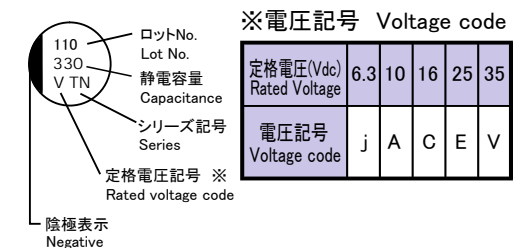

◆リップル電流補正係数/
MULTIPLIER FOR RIPPLE CURRENT

周波数 (Hz) Frequency	120	1k	10k	100k ≤
係数 Coefficient	0.60	0.85	0.95	1.00

◆呼称方法/PART NUMBER

□□□	TNV	□□□□□	M	□□□	D x L
定格電圧 Rated Voltage	シリーズ名 Series	静電容量 Capacitance	静電容量許容差 Capacitance Tolerance	副記号 Option	ケースサイズ Case Size

◆標準品一覧表/STANDARD SIZE

Size φD×L(mm), Rated Ripple Current (mA r.m.s./105°C, 100kHz), ESR(Ω MAX/20°C 100kHz)

Vdc	Cap (μF)	Size (φD×L)	Ripple	ESR
6.3	1200	8×10.5	850	0.08
	2200	10×10.5	1190	0.06
10	1000	8×10.5	850	0.08
	1500	10×10.5	1190	0.06
16	680	8×10.5	850	0.08
	1000	10×10.5	1190	0.06

Vdc	Cap (μF)	Size (φD×L)	Ripple	ESR
25	470	8×10.5	850	0.08
	820	10×10.5	1190	0.06
35	330	8×10.5	850	0.08
	560	10×10.5	1190	0.06

TPV series

105°C 2000時間 ESR品
Load life : 105°C 2000 hours, Low ESR

AEC-Q200



◆規格表/SPECIFICATIONS

項目 Item	特性 Characteristics																																
カテゴリ温度範囲 Category Temperature Range	-55~+105°C																																
定格電圧範囲 Rated Voltage Range	6.3~50Vdc																																
静電容量許容差 Capacitance Tolerance	±20%(20°C, 120Hz)																																
漏れ電流 Leakage Current (MAX)	I=0.01CV又は3μAのいずれか大なる値以下(定格電圧印加2分後) I=0.01CV or 3 μA whichever is greater. (After 2 minutes) I=漏れ電流(μA) C=静電容量(μF) V=定格電圧(Vdc) Leakage Current Capacitance Rated Voltage																																
損失角の正接(tan δ) Dissipation Factor(MAX)	<table border="1"> <tr> <td>定格電圧(Vdc) Rated Voltage</td> <td>6.3</td> <td>10</td> <td>16</td> <td>25</td> <td>35</td> <td>50</td> <td>(20°C, 120Hz)</td> </tr> <tr> <td>tan δ</td> <td>0.26</td> <td>0.19</td> <td>0.16</td> <td>0.14</td> <td>0.12</td> <td>0.10</td> <td></td> </tr> </table> <p>1000μFを超えるものは1000μF増す毎に上表の値に0.02を加えた値とする。 When rated capacitance is over 1000μF, tan δ shall be added 0.02 to the listed value with increase of every 1000μF.</p>	定格電圧(Vdc) Rated Voltage	6.3	10	16	25	35	50	(20°C, 120Hz)	tan δ	0.26	0.19	0.16	0.14	0.12	0.10																	
定格電圧(Vdc) Rated Voltage	6.3	10	16	25	35	50	(20°C, 120Hz)																										
tan δ	0.26	0.19	0.16	0.14	0.12	0.10																											
耐久性 Endurance	105°C, 2000時間定格電圧印加後、下記項目を満足すること。 After applying rated voltage 2000 hours at 105°C, the capacitors shall meet the following requirements. <table border="1"> <tr> <td>静電容量変化率 Capacitance Change</td> <td>初期値の ±30% 以内 Within ±30% of the initial value.</td> </tr> <tr> <td>損失角の正接 Dissipation Factor</td> <td>規格値の 200% 以下 Not more than 200% of the specified value.</td> </tr> <tr> <td>漏れ電流 Leakage Current</td> <td>規格値以下 Not more than the specified value.</td> </tr> </table>	静電容量変化率 Capacitance Change	初期値の ±30% 以内 Within ±30% of the initial value.	損失角の正接 Dissipation Factor	規格値の 200% 以下 Not more than 200% of the specified value.	漏れ電流 Leakage Current	規格値以下 Not more than the specified value.																										
静電容量変化率 Capacitance Change	初期値の ±30% 以内 Within ±30% of the initial value.																																
損失角の正接 Dissipation Factor	規格値の 200% 以下 Not more than 200% of the specified value.																																
漏れ電流 Leakage Current	規格値以下 Not more than the specified value.																																
低温特性 Low Temperature Stability (インピーダンス比) Impedance Ratio (MAX)	<table border="1"> <tr> <td>定格電圧(Vdc) Rated Voltage</td> <td>6.3</td> <td>10</td> <td>16</td> <td>25</td> <td>35</td> <td>50</td> <td>(120Hz)</td> </tr> <tr> <td>Z(-25°C)/Z(20°C)</td> <td>2</td> <td>2</td> <td>2</td> <td>2</td> <td>2</td> <td>2</td> <td></td> </tr> <tr> <td>Z(-40°C)/Z(20°C)</td> <td>3</td> <td>3</td> <td>3</td> <td>3</td> <td>3</td> <td>3</td> <td></td> </tr> <tr> <td>Z(-55°C)/Z(20°C)</td> <td>4</td> <td>4</td> <td>4</td> <td>3</td> <td>3</td> <td>3</td> <td></td> </tr> </table>	定格電圧(Vdc) Rated Voltage	6.3	10	16	25	35	50	(120Hz)	Z(-25°C)/Z(20°C)	2	2	2	2	2	2		Z(-40°C)/Z(20°C)	3	3	3	3	3	3		Z(-55°C)/Z(20°C)	4	4	4	3	3	3	
定格電圧(Vdc) Rated Voltage	6.3	10	16	25	35	50	(120Hz)																										
Z(-25°C)/Z(20°C)	2	2	2	2	2	2																											
Z(-40°C)/Z(20°C)	3	3	3	3	3	3																											
Z(-55°C)/Z(20°C)	4	4	4	3	3	3																											

◆呼称方法/PART NUMBER

□□□	TPV	□□□□□	M	□□□	D x L
定格電圧 Rated Voltage	シリーズ名 Series	静電容量 Capacitance	静電容量許容差 Capacitance Tolerance	副記号 Option	ケースサイズ Case Size

◆リップル電流補正係数/
MULTIPLIER FOR RIPPLE CURRENT

周波数 (Hz) Frequency	120	1k	10k	100k ≤
係数 Coefficient	0.44	0.80	0.95	1.00
	0.60	0.85	0.95	1.00

◆表示/MARKING

※電圧記号 Voltage code

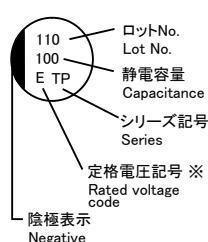

定格電圧(Vdc) Rated Voltage	6.3	10	16	25	35	50
電圧記号 Voltage code	j	A	C	E	V	H

◆寸法図／DIMENSIONS

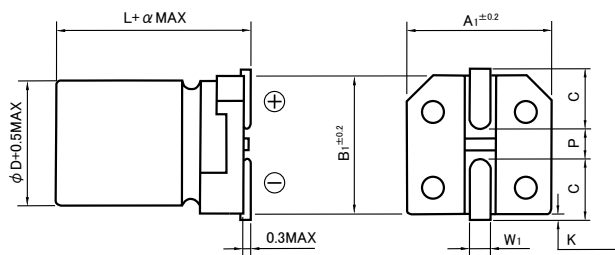

φD	L	A1	B1	C	W1	P	K	α
6.3	6.1	6.6	6.6	2.7	0.5~0.8	1.8	0.5MAX	0
6.3	8	6.6	6.6	2.7	0.5~0.8	1.8	0.5MAX	0
8	10.5	8.3	8.3	2.9	0.8~1.1	3.1	0.5MAX	0
10	10.5	10.3	10.3	3.2	0.8~1.1	4.5	0.5MAX	0

◆標準品一覧表／STANDARD SIZE

Size φD×L(mm), Rated Ripple Current (mA r.m.s./105°C, 100kHz), ESR(Ω MAX/20°C, 100kHz)

Vdc	Cap (μF)	Size (φD×L)	Ripple	ESR
6.3	330	6.3×6.1	300	0.26
	470	6.3×8	600	0.16
	680	6.3×8	600	0.16
	1200	8×10.5	850	0.08
	2200	10×10.5	1190	0.06
10	220	6.3×6.1	300	0.26
	330	6.3×8	600	0.16
	470	6.3×8	600	0.16
	1000	8×10.5	850	0.08
	1500	10×10.5	1190	0.06
16	150	6.3×6.1	300	0.26
	220	6.3×6.1	300	0.26
	330	6.3×8	600	0.16
	680	8×10.5	850	0.08
	1000	10×10.5	1190	0.06
25	100	6.3×6.1	300	0.26
	150	6.3×8	600	0.16
	220	6.3×8	600	0.16
	470	8×10.5	850	0.08
	560	8×10.5	850	0.08
	820	10×10.5	1190	0.06
	1000	10×10.5	1190	0.06

Vdc	Cap (μF)	Size (φD×L)	Ripple	ESR
35	68	6.3×6.1	300	0.26
	100	6.3×6.1	300	0.26
	150	6.3×8	600	0.16
	330	8×10.5	850	0.08
	470	8×10.5	850	0.08
	560	10×10.5	1190	0.06
50	680	10×10.5	1190	0.06
	47	6.3×6.1	195	0.68
	100	6.3×8	350	0.34
	220	8×10.5	670	0.18
	330	10×10.5	900	0.12

TRV series

105°C 5000~10000時間 低インピーダンス品
Load Life : 105°C 5000 ~ 10000 hours, Low Impedance



AEC-Q200



◆規格表/SPECIFICATIONS

項目 Item	特性 Characteristics																								
カテゴリ温度範囲 Category Temperature Range	-40~+105°C																								
定格電圧範囲 Rated Voltage Range	6.3~50Vdc																								
静電容量許容差 Capacitance Tolerance	±20%(20°C, 120Hz)																								
漏れ電流 Leakage Current (MAX)	I=0.01CV又は3μAのいずれか大なる値以下(定格電圧印加2分後) I=0.01CV or 3μA whichever is greater. (After 2 minutes) I=漏れ電流(μA) C=静電容量(μF) V=定格電圧(Vdc) Leakage Current Capacitance Rated Voltage																								
損失角の正接(tan δ) Dissipation Factor(MAX)	<table border="1"> <tr> <td>定格電圧 (Vdc) Rated Voltage</td> <td>6.3</td> <td>10</td> <td>16</td> <td>25</td> <td>35</td> <td>50</td> <td>(20°C, 120Hz)</td> </tr> <tr> <td>φ 6.3~10</td> <td>0.32</td> <td>0.28</td> <td>0.26</td> <td>0.16</td> <td>0.14</td> <td>0.14</td> <td></td> </tr> <tr> <td>φ 12.5~18</td> <td>0.30</td> <td>0.26</td> <td>0.22</td> <td>0.16</td> <td>0.14</td> <td>0.12</td> <td></td> </tr> </table> <p>1000μFを越えるものは1000μF増す毎に上表の値に0.02を加えた値とする。 When rated capacitance is over 1000μF, tan δ shall be added 0.02 to the listed value with increase of every 1000μF.</p>	定格電圧 (Vdc) Rated Voltage	6.3	10	16	25	35	50	(20°C, 120Hz)	φ 6.3~10	0.32	0.28	0.26	0.16	0.14	0.14		φ 12.5~18	0.30	0.26	0.22	0.16	0.14	0.12	
定格電圧 (Vdc) Rated Voltage	6.3	10	16	25	35	50	(20°C, 120Hz)																		
φ 6.3~10	0.32	0.28	0.26	0.16	0.14	0.14																			
φ 12.5~18	0.30	0.26	0.22	0.16	0.14	0.12																			
耐久性 Endurance	<p>105°C中で右表の時間定格電圧印加後、下記項目を満足すること。 After applying rated voltage for specified time at 105°C, the capacitors shall meet the following requirements.</p> <table border="1"> <tr> <td>静電容量変化率 Capacitance Change</td> <td>初期値の ±30% 以内 Within ±30% of the initial value.</td> <td>ケースサイズ Case Size</td> <td>時間(hrs) Life Time</td> </tr> <tr> <td>損失角の正接 Dissipation Factor</td> <td>規格値の 300% 以下 Not more than 300% of the specified value.</td> <td rowspan="2">φ D=6.3</td> <td>L=6.1 5000</td> </tr> <tr> <td>漏れ電流 Leakage Current</td> <td>規格値以下 Not more than the specified value.</td> <td>L=8 6000</td> </tr> <tr> <td></td> <td></td> <td>φ D=8,10</td> <td>8000</td> </tr> <tr> <td></td> <td></td> <td>φ D≥12.5</td> <td>10000</td> </tr> </table>	静電容量変化率 Capacitance Change	初期値の ±30% 以内 Within ±30% of the initial value.	ケースサイズ Case Size	時間(hrs) Life Time	損失角の正接 Dissipation Factor	規格値の 300% 以下 Not more than 300% of the specified value.	φ D=6.3	L=6.1 5000	漏れ電流 Leakage Current	規格値以下 Not more than the specified value.	L=8 6000			φ D=8,10	8000			φ D≥12.5	10000					
静電容量変化率 Capacitance Change	初期値の ±30% 以内 Within ±30% of the initial value.	ケースサイズ Case Size	時間(hrs) Life Time																						
損失角の正接 Dissipation Factor	規格値の 300% 以下 Not more than 300% of the specified value.	φ D=6.3	L=6.1 5000																						
漏れ電流 Leakage Current	規格値以下 Not more than the specified value.		L=8 6000																						
		φ D=8,10	8000																						
		φ D≥12.5	10000																						
低温特性 Low Temperature Stability (インピーダンス比) Impedance Ratio (MAX)	<table border="1"> <tr> <td>定格電圧 (Vdc) Rated Voltage</td> <td>6.3</td> <td>10</td> <td>16</td> <td>25</td> <td>35</td> <td>50</td> <td>(120Hz)</td> </tr> <tr> <td>Z(-40°C)/Z(20°C)</td> <td>4</td> <td>4</td> <td>4</td> <td>4</td> <td>3</td> <td>3</td> <td></td> </tr> </table>	定格電圧 (Vdc) Rated Voltage	6.3	10	16	25	35	50	(120Hz)	Z(-40°C)/Z(20°C)	4	4	4	4	3	3									
定格電圧 (Vdc) Rated Voltage	6.3	10	16	25	35	50	(120Hz)																		
Z(-40°C)/Z(20°C)	4	4	4	4	3	3																			

◆呼称方法/PART NUMBER



◆リップル電流補正係数/
MULTIPLIER FOR RIPPLE CURRENT

周波数 (Hz) Frequency	120	1k	10k	100k≤
10~33 μF	0.45	0.75	0.90	1.00
47~100 μF	0.50	0.80	0.95	1.00
220~8200 μF	0.60	0.85	0.95	1.00

◆表示/MARKING

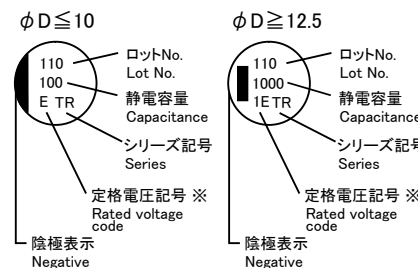

※電圧記号 Voltage code

定格電圧 (Vdc) Rated Voltage	6.3	10	16
記号 code	φ D ≤ 10 j	A	C
	φ D ≥ 12.5 0J	1A	1C
定格電圧 (Vdc) Rated Voltage	25	35	50
記号 code	φ D ≤ 10 E	V	H
	φ D ≥ 12.5 1E	1V	1H

◆寸法図／DIMENSIONS

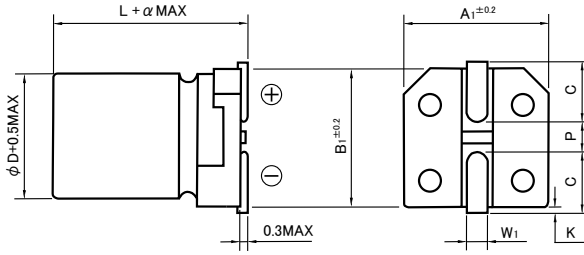

ϕD	L	A1	B1	C	W1	P	K	α
6.3	6.1	6.6	6.6	2.7	0.5~0.8	1.8	0.5MAX	0
6.3	8	6.6	6.6	2.7	0.5~0.8	1.8	0.5MAX	0
8	10.5	8.3	8.3	2.9	0.8~1.1	3.1	0.5MAX	0
10	10.5	10.3	10.3	3.2	0.8~1.1	4.5	0.5MAX	0
12.5	13.5	13	13	4.9	0.8~1.1	4.5	0.7±0.4	0.5
12.5	16	13	13	4.9	0.8~1.1	4.5	0.7±0.4	0.5
16	16.5	17	17	6	1.0~1.6	6.8	0.7±0.4	0.5
16	21.5	17	17	6	1.0~1.6	6.8	0.7±0.4	0.5
18	16.5	19	19	7	1.0~1.6	6.8	0.7±0.4	0.5
18	21.5	19	19	7	1.0~1.6	6.8	0.7±0.4	0.5

◆標準品一覧表／STANDARD SIZE

Size $\phi D \times L$ (mm), Rated Ripple Current (mA r.m.s./105°C, 100kHz), Impedance(Ω MAX/20°C, 100kHz)

Vdc	Cap (μF)	Size ($\phi D \times L$)	Ripple	Impedance
6.3	470	8×10.5	600	0.15
	820	10×10.5	850	0.12
	2200	12.5×13.5	950	0.092
	2700	12.5×16	1200	0.074
	3900	16×16.5	1450	0.066
	5600	18×16.5	1550	0.064
	6800	16×21.5	2000	0.041
	8200	18×21.5	2150	0.039
10	330	8×10.5	600	0.15
	680	10×10.5	850	0.12
	1800	12.5×13.5	950	0.092
	2200	12.5×16	1200	0.074
	3300	16×16.5	1450	0.066
	4700	18×16.5	1550	0.064
	5600	16×21.5	2000	0.041
	6800	18×21.5	2150	0.039
16	330	8×10.5	600	0.15
	470	10×10.5	850	0.12
	1500	12.5×13.5	950	0.092
	1800	12.5×16	1200	0.074
	2200	16×16.5	1450	0.066
	3300	18×16.5	1550	0.064
	4700	16×21.5	2000	0.041
	5600	18×21.5	2150	0.039

Vdc	Cap (μF)	Size ($\phi D \times L$)	Ripple	Impedance	
25	100	6.3×8	230	0.7	
	220	8×10.5	600	0.15	
	330	10×10.5	850	0.12	
	1000	12.5×13.5	950	0.092	
	1200	12.5×16	1200	0.074	
	1500	16×16.5	1450	0.066	
	2200	18×16.5	1550	0.064	
	2700	16×21.5	2000	0.041	
	3300	18×21.5	2150	0.039	
	35	10	6.3×6.1	140	1
22		6.3×6.1	140	1	
33		6.3×6.1	140	1	
47		6.3×8	230	0.7	
100		8×10.5	600	0.15	
220		10×10.5	850	0.12	
470		12.5×13.5	950	0.092	
680		12.5×16	1200	0.074	
1000		16×16.5	1450	0.066	
1500		18×16.5	1550	0.064	
2200		16×21.5	2000	0.041	
2700		18×21.5	2150	0.039	
50		10	6.3×6.1	140	1
		33	6.3×8	230	0.7
	47	8×10.5	350	0.36	
	100	10×10.5	670	0.25	
	330	12.5×13.5	850	0.18	
	390	12.5×16	950	0.15	
	470	16×16.5	1200	0.12	
	820	18×16.5	1300	0.12	
	1000	16×21.5	1600	0.08	
	1500	18×21.5	1650	0.072	

TSV series

150°C 1000~1500時間 低ESR品
Load life : 150°C 1000~1500 hours, Low ESR

AEC-Q200



◆規格表 / SPECIFICATIONS

項目 Item	特性 Characteristics													
カテゴリ温度範囲 Category Temperature Range	-40~+150°C													
定格電圧範囲 Rated Voltage Range	25~35Vdc													
静電容量許容差 Capacitance Tolerance	±20%(20°C, 120Hz)													
漏れ電流 Leakage Current (MAX)	I=0.01CV又は3μAのいずれか大なる値以下(定格電圧印加2分後) I=0.01CV or 3μA whichever is greater. (After 2 minutes) I=漏れ電流(μA) C=静電容量(μF) V=定格電圧(Vdc) Leakage Current Capacitance Rated Voltage													
損失角の正接(tan δ) Dissipation Factor(MAX)	<table border="1"> <tr> <td>定格電圧(Vdc) Rated Voltage</td> <td>25</td> <td>35</td> <td rowspan="3">(20°C, 120Hz)</td> </tr> <tr> <td>φ8~φ10</td> <td>0.18</td> <td>0.16</td> </tr> <tr> <td>φ12.5~φ18</td> <td>0.16</td> <td>0.14</td> </tr> </table> <p>1000μFを越えるものは1000μF増す毎に上表の値に0.02を加えた値とする。 When capacitance is over 1000μF, tan δ shall be added 0.02 to the listed value with increase of every 1000μF</p>	定格電圧(Vdc) Rated Voltage	25	35	(20°C, 120Hz)	φ8~φ10	0.18	0.16	φ12.5~φ18	0.16	0.14			
定格電圧(Vdc) Rated Voltage	25	35	(20°C, 120Hz)											
φ8~φ10	0.18	0.16												
φ12.5~φ18	0.16	0.14												
耐久性 Endurance	<p>150°C中で右表の時間定格電圧印加後、下記項目を満足すること。 After applying rated voltage for specified time at 150°C, the capacitors shall meet the following Criteria.</p> <table border="1"> <tr> <td>静電容量変化率 Capacitance Change</td> <td>初期値の ±30% 以内 Within ±30% of the initial value.</td> <td rowspan="3"> <table border="1"> <tr> <th>ケースサイズ Case Size</th> <th>時間(hrs) Life Time</th> </tr> <tr> <td>φD ≤ 10</td> <td>1000</td> </tr> <tr> <td>φD ≥ 12.5</td> <td>1500</td> </tr> </table> </td> </tr> <tr> <td>損失角の正接 Dissipation Factor</td> <td>規格値の 300% 以下 Not more than 300% of the specified value.</td> </tr> <tr> <td>漏れ電流 Leakage Current</td> <td>規格値以下 Not more than the specified value.</td> </tr> </table>	静電容量変化率 Capacitance Change	初期値の ±30% 以内 Within ±30% of the initial value.	<table border="1"> <tr> <th>ケースサイズ Case Size</th> <th>時間(hrs) Life Time</th> </tr> <tr> <td>φD ≤ 10</td> <td>1000</td> </tr> <tr> <td>φD ≥ 12.5</td> <td>1500</td> </tr> </table>	ケースサイズ Case Size	時間(hrs) Life Time	φD ≤ 10	1000	φD ≥ 12.5	1500	損失角の正接 Dissipation Factor	規格値の 300% 以下 Not more than 300% of the specified value.	漏れ電流 Leakage Current	規格値以下 Not more than the specified value.
静電容量変化率 Capacitance Change	初期値の ±30% 以内 Within ±30% of the initial value.	<table border="1"> <tr> <th>ケースサイズ Case Size</th> <th>時間(hrs) Life Time</th> </tr> <tr> <td>φD ≤ 10</td> <td>1000</td> </tr> <tr> <td>φD ≥ 12.5</td> <td>1500</td> </tr> </table>	ケースサイズ Case Size		時間(hrs) Life Time	φD ≤ 10	1000	φD ≥ 12.5	1500					
ケースサイズ Case Size	時間(hrs) Life Time													
φD ≤ 10	1000													
φD ≥ 12.5	1500													
損失角の正接 Dissipation Factor	規格値の 300% 以下 Not more than 300% of the specified value.													
漏れ電流 Leakage Current	規格値以下 Not more than the specified value.													
低温特性 Low Temperature Stability (インピーダンス比) Impedance Ratio (MAX)	<table border="1"> <tr> <td>定格電圧(Vdc) Rated Voltage</td> <td>25</td> <td>35</td> <td rowspan="2">(120Hz)</td> </tr> <tr> <td>Z(-40°C) / Z(20°C)</td> <td>3</td> <td>3</td> </tr> </table>	定格電圧(Vdc) Rated Voltage	25	35	(120Hz)	Z(-40°C) / Z(20°C)	3	3						
定格電圧(Vdc) Rated Voltage	25	35	(120Hz)											
Z(-40°C) / Z(20°C)	3	3												

◆呼称方法 / PART NUMBER

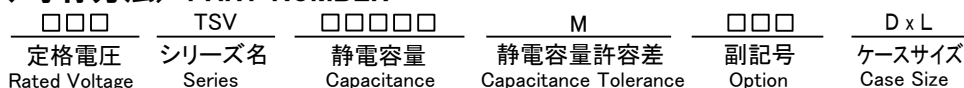

◆リップル電流補正係数 / MULTIPLIER FOR RIPPLE CURRENT

周波数 (Hz) Frequency	120	1k	10k	100k ≤
47~560 μF	0.50	0.74	0.94	1.00
750~1800 μF	0.60	0.74	0.94	1.00
2400 μF	0.64	0.75	0.95	1.00

◆表示 / MARKING

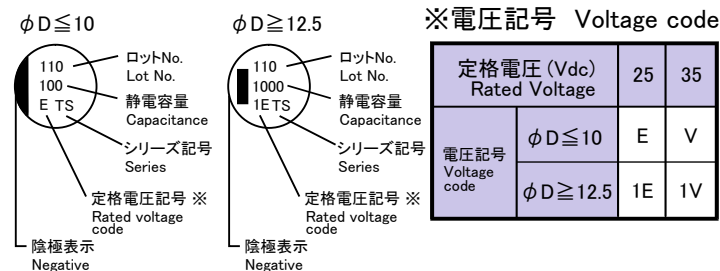

◆寸法図／DIMENSIONS

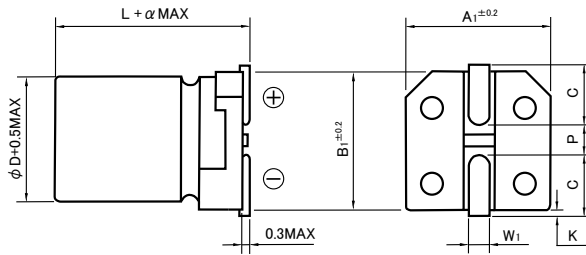

									(mm)
ϕD	L	A1	B1	C	W1	P	K	α	
8	10.5	8.3	8.3	2.9	0.8~1.1	3.1	0.5MAX	0	
10	10.5	10.3	10.3	3.2	0.8~1.1	4.5	0.5MAX	0	
12.5	13.5	13	13	4.9	0.8~1.1	4.5	0.7±0.4	0.5	
12.5	16	13	13	4.9	0.8~1.1	4.5	0.7±0.4	0.5	
16	16.5	17	17	6	1.0~1.6	6.8	0.7±0.4	0.5	
16	21.5	17	17	6	1.0~1.6	6.8	0.7±0.4	0.5	
18	16.5	19	19	7	1.0~1.6	6.8	0.7±0.4	0.5	
18	21.5	19	19	7	1.0~1.6	6.8	0.7±0.4	0.5	

◆標準品一覧表／STANDARD SIZE

Size $\phi D \times L$ (mm), Rated Ripple Current (mA r.m.s./150°C, 100kHz), ESR(Ω MAX/100kHz)

Vdc	Cap (μF)	Size ($\phi D \times L$)	Ripple	ESR	
				20°C	-40°C
25	100	8×10.5	110	0.18	3.0
	220	10×10.5	150	0.12	2.0
	560	12.5×13.5	940	0.10	1.6
	750	12.5×16	1120	0.078	1.3
	1000	16×16.5	1170	0.070	1.0
	1500	18×16.5	1240	0.065	0.80
	1800	16×21.5	1520	0.042	0.60
	2400	18×21.5	1610	0.040	0.50
35	47	8×10.5	110	0.18	3.0
	100	10×10.5	150	0.12	2.0
	330	12.5×13.5	940	0.10	1.6
	390	12.5×16	1120	0.078	1.3
	560	16×16.5	1170	0.070	1.0
	750	18×16.5	1240	0.065	0.80
	910	16×21.5	1520	0.042	0.60
	1200	18×21.5	1610	0.040	0.50

TXV series

125°C 1000~2000時間 低ESR品
Load Life : 125°C 1000~2000 hours, Low ESR

AEC-Q200

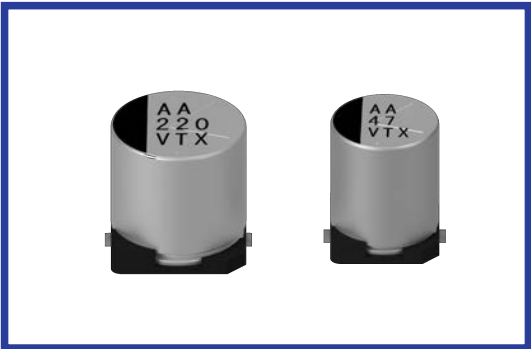

◆規格表/SPECIFICATIONS

項目 Item	特性 Characteristics					
カテゴリ温度範囲 Category Temperature Range	-40~+125°C					
定格電圧範囲 Rated Voltage Range	10~35Vdc					
静電容量許容差 Capacitance Tolerance	±20% (20°C, 120Hz)					
漏れ電流 Leakage Current (MAX)	I=0.01CV 又は 3μA のいずれか大なる値以下 (定格電圧印加2分後) I=0.01CV or 3μA whichever is greater. (After 2 minutes) I=漏れ電流(μA) C=静電容量(μF) V=定格電圧(Vdc) Leakage Current Capacitance Rated Voltage					
損失角の正接 (tan δ) Dissipation Factor(MAX)	定格電圧 (Vdc) Rated Voltage	10	16	25	35	(20°C, 120Hz)
	tan δ	0.30	0.20	0.18	0.16	
耐久性 Endurance	125°C中で表の時間定格電圧(リプル重量)印加後、下記項目を満足すること。 After applying rated voltage with rated ripple current for specified time at 125°C, the capacitors shall meet the following requirements.					
	静電容量変化率 Capacitance Change	初期値の±30%以内 Within ±30% of the initial value.				
	損失角の正接 Dissipation Factor	規格値の300%以下 Not more than 300% of the specified value.				
	漏れ電流 Leakage Current	規格値以下 Not more than the specified value.				
	ケースサイズ Case Size	時間(hrs) LifeTime				
	φD=6.3	1000				
	φD≥8	2000				
低温特性 Low Temperature Stability (インピーダンス比) Impedance Ratio (MAX)	定格電圧 (Vdc) Rated Voltage	10	16	25	35	(120Hz)
	Z(-40°C) / Z(20°C)	6	4	4	3	

◆寸法図/DIMENSIONS

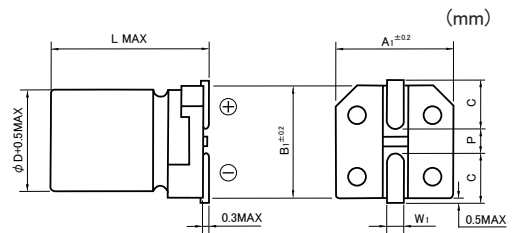

φD	L	A1	B1	C	W1	P
6.3	6.1	6.6	6.6	2.7	0.5~0.8	1.8
6.3	8	6.6	6.6	2.7	0.5~0.8	1.8
8	10.5	8.3	8.3	2.9	0.8~1.1	3.1
10	10.5	10.3	10.3	3.2	0.8~1.1	4.5

◆表示/MARKING

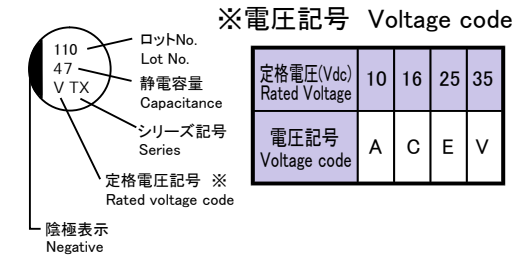

◆リップル電流補正係数/
MULTIPLIER FOR RIPPLE CURRENT

周波数 (Hz) Frequency	120	1k	10k	100k≤
22~33 μF	0.45	0.75	0.90	1.00
47~100 μF	0.50	0.80	0.95	1.00
220~470 μF	0.60	0.85	0.95	1.00

◆呼称方法/PART NUMBER



◆標準品一覧表/STANDARD SIZE

Size φD×L(mm), Rated Ripple Current (mA r.m.s./125°C, 100kHz), ESR(Ω MAX/100kHz)

Vdc	Cap (μF)	Size (φD×L)	Ripple	ESR	
				20°C	-40°C
10	100	6.3×8	140	0.3	5
	220	6.3×8	110	0.7	11
	470	10×10.5	300	0.2	3
16	47	6.3×6.1	70	1	15
		6.3×8	140	0.3	5

Vdc	Cap (μF)	Size (φD×L)	Ripple	ESR	
				20°C	-40°C
25	33	6.3×6.1	70	1	15
	47	6.3×8	140	0.3	5
		6.3×8	110	0.7	11
	100	8×10.5	300	0.16	2.5
		8×10.5	220	0.3	4.5
	220	10×10.5	420	0.1	1.5
330	10×10.5	300	0.2	3	

Vdc	Cap (μF)	Size (φD×L)	Ripple	ESR	
				20°C	-40°C
35	22	6.3×6.1	70	1	15
	33	6.3×8	140	0.3	5
		6.3×8	110	0.7	11
	47	8×10.5	300	0.16	2.5
		8×10.5	220	0.3	4.5
	100	10×10.5	420	0.1	1.5
220	10×10.5	300	0.2	3	

TZV series

105°C 2000時間 低インピーダンス品
Load life : 105°C 2000 hours, Low Impedance

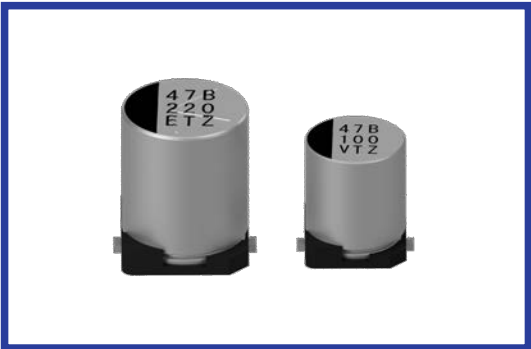

AEC-Q200



◆規格表 / SPECIFICATIONS

項目 Item	特性 Characteristics																																
カテゴリ温度範囲 Category Temperature Range	-55~+105°C																																
定格電圧範囲 Rated Voltage Range	6.3~50Vdc																																
静電容量許容差 Capacitance Tolerance	±20%(20°C, 120Hz)																																
漏れ電流 Leakage Current (MAX)	I=0.01CV又は3μAのいずれか大なる値以下(定格電圧印加2分後) I=0.01CV or 3 μA whichever is greater. (After 2 minutes) I=漏れ電流(μA) C=静電容量(μF) V=定格電圧(Vdc) Leakage Current Capacitance Rated Voltage																																
損失角の正接(tan δ) Dissipation Factor(MAX)	<table border="1"> <tr> <td>定格電圧 (Vdc) Rated Voltage</td> <td>6.3</td> <td>10</td> <td>16</td> <td>25</td> <td>35</td> <td>50</td> <td>(20°C, 120Hz)</td> </tr> <tr> <td>tan δ</td> <td>0.26</td> <td>0.19</td> <td>0.16</td> <td>0.14</td> <td>0.12</td> <td>0.10</td> <td></td> </tr> </table>	定格電圧 (Vdc) Rated Voltage	6.3	10	16	25	35	50	(20°C, 120Hz)	tan δ	0.26	0.19	0.16	0.14	0.12	0.10																	
定格電圧 (Vdc) Rated Voltage	6.3	10	16	25	35	50	(20°C, 120Hz)																										
tan δ	0.26	0.19	0.16	0.14	0.12	0.10																											
耐久性 Endurance	105°C中で2000時間定格電圧(リップル重畳)印加後、下記項目を満足すること。 After applying rated voltage with rated ripple current for 2000 hours at 105°C, the capacitors shall meet the following requirements. <table border="1"> <tr> <td>静電容量変化率 Capacitance Change</td> <td>初期値の ±30% 以内 Within ±30% of the initial value.</td> </tr> <tr> <td>損失角の正接 Dissipation Factor</td> <td>規格値の 200% 以下 Not more than 200% of the specified value.</td> </tr> <tr> <td>漏れ電流 Leakage Current</td> <td>規格値以下 Not more than the specified value.</td> </tr> </table>	静電容量変化率 Capacitance Change	初期値の ±30% 以内 Within ±30% of the initial value.	損失角の正接 Dissipation Factor	規格値の 200% 以下 Not more than 200% of the specified value.	漏れ電流 Leakage Current	規格値以下 Not more than the specified value.																										
静電容量変化率 Capacitance Change	初期値の ±30% 以内 Within ±30% of the initial value.																																
損失角の正接 Dissipation Factor	規格値の 200% 以下 Not more than 200% of the specified value.																																
漏れ電流 Leakage Current	規格値以下 Not more than the specified value.																																
低温特性 Low Temperature Stability (インピーダンス比) Impedance Ratio (MAX)	<table border="1"> <tr> <td>定格電圧 (Vdc) Rated Voltage</td> <td>6.3</td> <td>10</td> <td>16</td> <td>25</td> <td>35</td> <td>50</td> <td>(120Hz)</td> </tr> <tr> <td>Z(-25°C)/Z(20°C)</td> <td>2</td> <td>2</td> <td>2</td> <td>2</td> <td>2</td> <td>2</td> <td></td> </tr> <tr> <td>Z(-40°C)/Z(20°C)</td> <td>3</td> <td>3</td> <td>3</td> <td>3</td> <td>3</td> <td>3</td> <td></td> </tr> <tr> <td>Z(-55°C)/Z(20°C)</td> <td>4</td> <td>4</td> <td>4</td> <td>3</td> <td>3</td> <td>3</td> <td></td> </tr> </table>	定格電圧 (Vdc) Rated Voltage	6.3	10	16	25	35	50	(120Hz)	Z(-25°C)/Z(20°C)	2	2	2	2	2	2		Z(-40°C)/Z(20°C)	3	3	3	3	3	3		Z(-55°C)/Z(20°C)	4	4	4	3	3	3	
定格電圧 (Vdc) Rated Voltage	6.3	10	16	25	35	50	(120Hz)																										
Z(-25°C)/Z(20°C)	2	2	2	2	2	2																											
Z(-40°C)/Z(20°C)	3	3	3	3	3	3																											
Z(-55°C)/Z(20°C)	4	4	4	3	3	3																											

◆呼称方法 / PART NUMBER

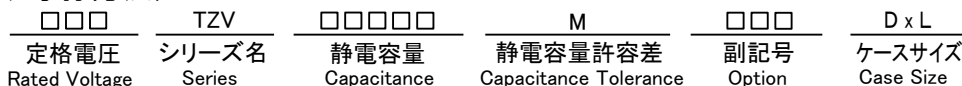

◆リップル電流補正係数 / MULTIPLIER FOR RIPPLE CURRENT

周波数 (Hz) Frequency	120	1k	10k	100k ≤
4.7 μF	0.30	0.60	0.80	1.00
10~47 μF	0.32	0.75	0.90	1.00
100 μF	0.50	0.80	0.95	1.00
220~1000 μF	0.60	0.85	0.95	1.00

◆表示 / MARKING

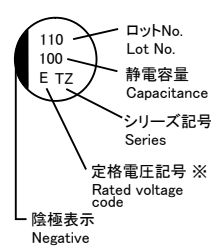

※電圧記号 Voltage code

定格電圧 (Vdc) Rated Voltage	6.3	10	16	25	35	50
電圧記号 Voltage code	j	A	C	E	V	H

◆寸法図／DIMENSIONS

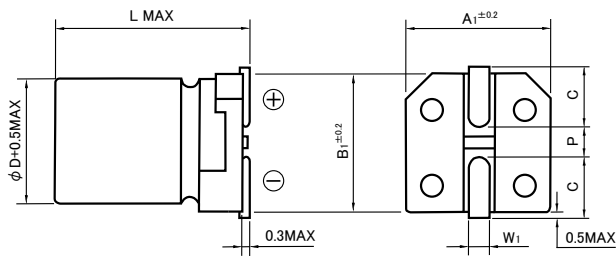

φD	L	A1	B1	C	W1	P
4	6.1	4.3	4.3	1.8	0.5~0.8	1.0
5	6.1	5.3	5.3	2.2	0.5~0.8	1.3
6.3	6.1	6.6	6.6	2.7	0.5~0.8	1.8
6.3	8	6.6	6.6	2.7	0.5~0.8	1.8
8	10.5	8.3	8.3	2.9	0.8~1.1	3.1
10	10.5	10.3	10.3	3.2	0.8~1.1	4.5

◆標準品一覧表／STANDARD SIZE

Size φD×L(mm), Rated Ripple Current (mA r.m.s./105°C, 100kHz), Impedance(Ω MAX/20°C, 100kHz)

Vdc	Cap (μF)	Size (φD×L)	Ripple	Impedance
6.3	22	4×6.1	90	1.35
	47	4×6.1	90	1.35
		5×6.1	170	0.70
	100	5×6.1	170	0.70
		6.3×6.1	250	0.36
	220	6.3×6.1	250	0.36
		6.3×8	300	0.34
	330	6.3×8	300	0.34
1000	8×10.5	600	0.16	
10	33	4×6.1	90	1.35
	220	6.3×8	300	0.34
	470	8×10.5	600	0.16
	680	8×10.5	600	0.16
	1000	10×10.5	850	0.08
16	10	4×6.1	90	1.35
	22	4×6.1	90	1.35
		5×6.1	170	0.70
	33	5×6.1	170	0.70
	47	5×6.1	170	0.70
		6.3×6.1	250	0.36
	100	6.3×6.1	250	0.36
		6.3×8	300	0.34
	220	6.3×8	300	0.34
	330	8×10.5	600	0.16
470	8×10.5	600	0.16	
680	10×10.5	850	0.08	

Vdc	Cap (μF)	Size (φD×L)	Ripple	Impedance
25	33	5×6.1	170	0.70
		6.3×6.1	250	0.36
	47	6.3×6.1	250	0.36
	100	6.3×8	300	0.34
	220	8×10.5	600	0.16
	330	8×10.5	600	0.16
	470	10×10.5	850	0.09
	35	4.7	4×6.1	90
10		4×6.1	90	1.45
		5×6.1	170	0.70
22		5×6.1	170	0.70
		6.3×6.1	250	0.36
33		6.3×6.1	250	0.36
47		6.3×6.1	250	0.36
		6.3×8	300	0.34
100		6.3×8	300	0.34
		8×10.5	600	0.16
220	8×10.5	600	0.16	
330	10×10.5	850	0.09	
50	4.7	4×6.1	60	2.90
	10	5×6.1	85	1.52
		6.3×6.1	165	0.88
	22	6.3×6.1	165	0.88
	33	6.3×8	195	0.68
	47	6.3×8	195	0.68
	100	8×10.5	350	0.34
	220	10×10.5	670	0.18

AX series

105°C 2000時間品 超小形化品
Load Life: 105°C 2000 hours, Ultra Miniaturized

・携帯機器 ACアダプタ用
Suitable for AC-adaptor of portable device.



◆規格表 / SPECIFICATIONS

項目 Item	特性 Characteristics	
カテゴリ温度範囲 Category Temperature Range	-40~+105°C	
定格電圧範囲 Rated Voltage Range	6.3~35, 400Vdc	
静電容量許容差 Capacitance Tolerance	±20%(20°C, 120Hz)	
漏れ電流 Leakage Current (MAX)	6.3~35Vdc	400Vdc
	I=0.01CV又は3µAのいずれか大なる値以下 (定格電圧印加2分後) I=0.01CV or 3µA whichever is greater. (After 2 minutes)	I=0.04CV+100µA以下(定格電圧印加1分後) I=0.04CV+100µA (After 1 minute application of rated voltage) I=0.02CV+25µA以下(定格電圧印加5分後) I=0.02CV+25µA (After 5 minutes application of rated voltage)
I=漏れ電流(µA) C=静電容量(µF) V=定格電圧(Vdc) Leakage Current Capacitance Rated Voltage		
損失角の正接(tan δ) Dissipation Factor (MAX)	定格電圧(Vdc) Rated Voltage	6.3 8 10 16 25 35 400 (20°C, 120Hz)
	tan δ	0.22 0.20 0.19 0.16 0.14 0.12 0.25
耐久性 Endurance	105°C中で2000時間定格電圧(リップル重畳)印加後、下記項目を満足すること。 After applying rated voltage with rated ripple current for 2000 hours at 105°C, the capacitors shall meet the following requirements.	
	静電容量変化率 Capacitance Change	初期値の±25%以内 Within ±25% of the initial value.
	損失角の正接 Dissipation Factor	規格値の200%以下 Not more than 200% of the specified value.
低温特性 Low Temperature Stability (インピーダンス比) Impedance Ratio (MAX)	定格電圧(Vdc) Rated Voltage	6.3 8 10 16 25 35 400 (120Hz)
	Z(-25°C)/Z(+20°C)	2 2 2 2 2 2 6
	Z(-40°C)/Z(+20°C)	12 12 12 10 8 6 10

◆呼称方法 / PART NUMBER

□□□ AX □□□□□ M □□□ □□ D x L
 Rated Voltage Series Capacitance Capacitance Tolerance Option Lead Forming Case Size

◆副記号 / OPTION

EFC: PETスリーブ PET Sleeve

◆リップル電流補正係数 / MULTIPLIER FOR RIPPLE CURRENT

6.3~35Vdc						400Vdc							
Frequency (Hz)		120	1k	10k	100k ≤	Frequency (Hz)		60(50)	120	500	1k	10k ≤	
係数 Coefficient	150~270µF	0.36	0.73	0.92	1.00	係数 Coefficient	4.7~8.2µF	0.65	1.00	1.20	1.30	1.50	
	330~750µF	0.55	0.77	0.94	1.00		係数 Coefficient	10~24µF	0.80	1.00	1.20	1.30	1.50
	820~1200µF	0.60	0.80	0.96	1.00								

◆寸法図／DIMENSIONS

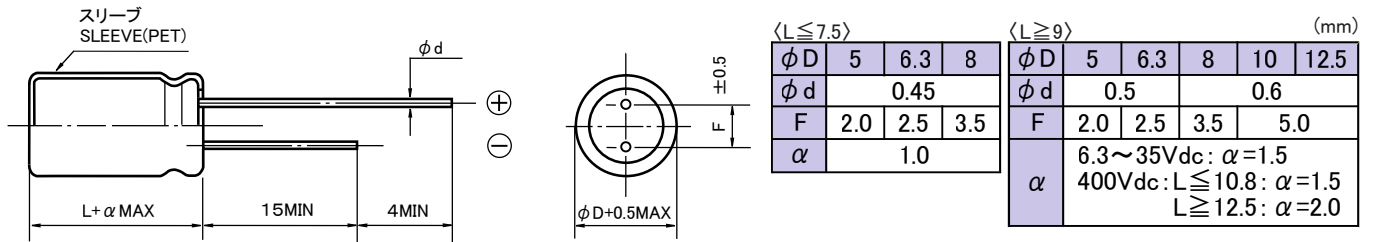

◆標準品一覧表／STANDARD SIZE

Rated Ripple Current (mA r.m.s./105°C, 100kHz),
Impedance (Ω MAX/20°C, 100kHz)

定格電圧 Rated Voltage (Vdc)	静電容量 Capacitance (μF)	外形寸法 Size $\phi D \times L$ (mm)	定格リプル 電流 Rated Ripple Current	インピーダンス Impedance
6.3	220	5×11	800	0.14
	470	6.3×11	1140	0.067
	680	8×9	1360	0.049
	820	8×10.8	1600	0.042
	1000	8×16	2010	0.027
		10×9	1540	0.036
	1200	10×12.5	1970	0.025
8	200	5×11	800	0.14
	430	6.3×11	1140	0.067
	620	8×9	1360	0.049
	750	8×10.8	1600	0.042
	910	8×16	2010	0.027
		10×9	1540	0.036
	1100	10×12.5	1970	0.025
10	180	5×1	800	0.14
	390	6.3×11	1140	0.067
	560	8×9	1360	0.049
	680	8×10.8	1600	0.042
	820	8×16	2010	0.027
		10×9	1540	0.036
1000	10×12.5	1970	0.025	
16	390	8×9	1360	0.049
	470	8×10.8	1600	0.042
	560	8×16	2010	0.027
		10×9	1540	0.036
	680	10×12.5	1970	0.025
1000	10×16	2480	0.019	
25	220	8×9	1360	0.049
	270	8×10.8	1600	0.042
	390	8×16	2010	0.027
		10×9	1540	0.036
	470	10×12.5	1970	0.025
	680	10×16	2480	0.019
35	150	8×9	1360	0.049
	180	8×10.8	1600	0.042
	220	8×16	2010	0.027
		10×9	1540	0.036
	270	10×12.5	1970	0.025
	390	10×16	2480	0.019

Rated Ripple Current (mA r.m.s./105°C, 120Hz)

定格電圧 Rated Voltage (Vdc)	静電容量 Capacitance (μF)	外形寸法 Size $\phi D \times L$ (mm)	定格リプル 電流 Rated Ripple Current
400	4.7	8×9	50
	6.8	8×10.8	70
	7.5	8×10.8	75
	8.2	8×16	85
		10×9	
	10	8×16	90
		10×12.5	100
	12	8×20	120
		10×12.5	110
	15	8×20	130
		10×16	150
	18	10×16	150
	22	12.5×16	180
	24	12.5×16	190

BXG series

105°C 10000~12000時間品
Load Life: 105°C 10000~12000 hours



◆規格表/SPECIFICATIONS

項目 Item	特性 Characteristics							
カテゴリ温度範囲 Category Temperature Range	-40~+105°C							
定格電圧範囲 Rated Voltage Range	160~450Vdc							
静電容量許容差 Capacitance Tolerance	±20%(20°C, 120Hz)							
漏れ電流 Leakage Current (MAX)	I=0.04CV+100µA以下(1分値) I=0.04CV+100µA (1minute) I=0.02CV+25µA以下(5分値) I=0.02CV+25µA (5minutes)			I=漏れ電流(µA) Leakage Current C=静電容量(µF) Capacitance V=定格電圧(Vdc) Rated Voltage				
損失角の正接(tan δ) Dissipation Factor (MAX)	定格電圧 (Vdc) Rated Voltage	160	200	250	350	400	450	(20°C, 120Hz)
	tan δ	0.15	0.15	0.15	0.20	0.20	0.20	
耐久性 Endurance	105°C中で右表の時間定格電圧(リップル重畳)印加後、下記項目を満足すること。 After applying rated voltage with rated ripple current for specified time at 105°C, the capacitors shall meet the following requirements.							
	静電容量変化率 Capacitance Change	初期値の±20%以内 Within ±20% of the initial value.					ケースサイズ Case Size	時間(hrs) Time(hrs)
	損失角の正接 Dissipation Factor	規格値の 200% 以下 Not more than 200% of the specified value.					φD=10	10000
低温特性 Low Temperature Stability (インピーダンス比) Impedance Ratio (MAX)	漏れ電流 Leakage Current	規格値以下 Not more than the specified value.					φD≥12.5	12000
	定格電圧 (Vdc) Rated Voltage	160	200	250	350	400	450	(120Hz)
	Z(-25°C)/Z(+20°C)	3	3	3	5	5	6	
Z(-40°C)/Z(+20°C)	6	6	6	6	6	10		

◆呼称方法/PART NUMBER

BXG M D x L
 定格電圧 シリーズ名 静電容量 静電容量許容差 副記号 リード加工記号 ケースサイズ
 Rated Voltage Series Capacitance Capacitance Tolerance Option Lead Forming Case Size

◆副記号/OPTION

EFC : PETスリーブ PET Sleeve

◆リップル電流補正係数/MULTIPLIER FOR RIPPLE CURRENT

Frequency (Hz)	120	1k	10k	100k≤	
係数 Coefficient	8.2~18µF	0.30	0.60	0.90	1.00
	22~82µF	0.40	0.70	0.90	1.00
	100~270µF	0.45	0.75	0.90	1.00

◆寸法図／DIMENSIONS

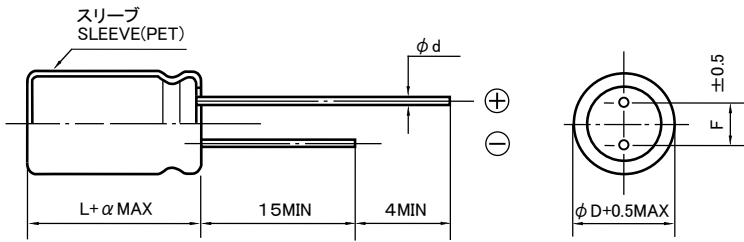

(mm)

ϕD	10	12.5	16	18
ϕd	0.6		0.8	
F	5.0		7.5	
α	2.0			

◆標準品一覧表／STANDARD SIZE

Rated Ripple Current (mA r.m.s./105°C, 100kHz)

定格電圧 Rated Voltage (Vdc)	静電容量 Capacitance (μF)	外形寸法 Size $\phi D \times L$ (mm)	定格リプル電流 Rated Ripple Current
160	39	10x16	630
	47	10x20	800
	56	10x20	860
	68	12.5x20	1200
	82	12.5x20	1280
	100	12.5x25	1450
	120	12.5x25	1500
	150	16x20	1650
	180	16x25	2000
		18x20	1700
	220	16x25	2100
	270	18x25	2370
200	33	10x16	630
	39	10x20	800
	47	10x20	860
	56	12.5x20	1100
	68	12.5x20	1200
	82	12.5x25	1450
	100	12.5x25	1480
	120	16x20	1600
	150	16x25	1900
		18x20	1700
	220	18x25	2370
	250	22	10x16
33		10x20	630
39		10x20	800
47		12.5x20	1000
56		12.5x20	1100
68		12.5x25	1350
82		16x20	1480
100		16x25	1600
120		16x25	1700
		18x20	1600
150	18x25	2000	
350	15	10x16	450
	22	10x20	550
	33	12.5x20	750
	39	12.5x25	900
	47	12.5x25	980
	56	16x20	1100
	68	16x25	1300
		18x20	1280
	82	18x25	1550
	100	18x25	1600

定格電圧 Rated Voltage (Vdc)	静電容量 Capacitance (μF)	外形寸法 Size $\phi D \times L$ (mm)	定格リプル電流 Rated Ripple Current
400	10	10x16	380
	12	10x16	450
	15	10x20	500
	18	10x20	550
	22	12.5x20	650
	27	12.5x20	700
	33	12.5x25	850
	39	12.5x25	900
	47	16x20	1000
	56	16x25	1220
		18x20	1200
	82	18x25	1600
450	8.2	10x16	330
	10	10x16	380
	12	10x20	470
	15	10x20	500
	18	12.5x20	560
	22	12.5x20	600
	27	12.5x25	750
	33	16x20	860
	39	16x25	1000
		18x20	960
	47	16x25	1100
		18x20	1000
	56	18x25	1250
	68	18x25	1350

HBX series

125°C 3000時間品
Load Life: 125°C 3000 hours

- ・高リップル、低ESR 車載専用高信頼性。
High Ripple Current, Low ESR, High Reliability.
- ・高圧インバータ等のDCリンクに最適。
Suitable for DC Link of high voltage inverter.

AEC-Q200

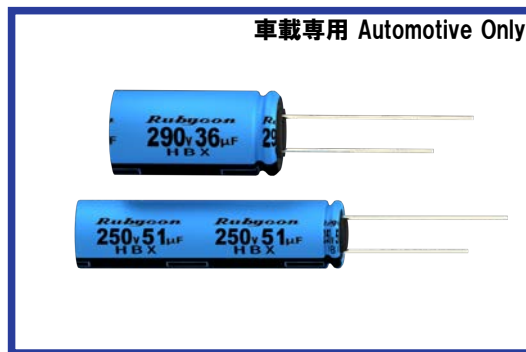

◆規格表/SPECIFICATIONS

項目 Item	特性 Characteristics													
カテゴリ温度範囲 Category Temperature Range	-40~+125°C													
定格電圧範囲 Rated Voltage Range	250~290Vdc													
静電容量許容差 Capacitance Tolerance	±20%(20°C, 120Hz)													
漏れ電流 Leakage Current (MAX)	I=0.04CV+100µA以下(定格電圧印加1分後) I=0.04CV+100µA (After 1 minute) I=漏れ電流(µA) C=静電容量(µF) V=定格電圧(Vdc) Leakage Current Capacitance Rated Voltage													
損失角の正接(tan δ) Dissipation Factor (MAX)	<table border="1"> <tr> <td>定格電圧 (Vdc) Rated Voltage</td> <td>250</td> <td>275</td> <td>290</td> <td rowspan="2">(20°C, 120Hz)</td> </tr> <tr> <td>tan δ</td> <td>0.15</td> <td>0.15</td> <td>0.15</td> </tr> </table>	定格電圧 (Vdc) Rated Voltage	250	275	290	(20°C, 120Hz)	tan δ	0.15	0.15	0.15				
定格電圧 (Vdc) Rated Voltage	250	275	290	(20°C, 120Hz)										
tan δ	0.15	0.15	0.15											
耐久性 Endurance	<p>125°C中で3000時間定格電圧(リップル重畳)印加後、下記項目を満足すること。 After applying rated voltage with rated ripple current for 3000 hours at 125°C, the capacitors shall meet the following requirements.</p> <table border="1"> <tr> <td>静電容量変化率 Capacitance Change</td> <td>初期値の ±20% 以内 Within ±20% of the initial value.</td> </tr> <tr> <td>損失角の正接 Dissipation Factor</td> <td>規格値の 200% 以下 Not more than 200% of the specified value.</td> </tr> <tr> <td>漏れ電流 Leakage Current</td> <td>規格値以下 Not more than the specified value.</td> </tr> </table>	静電容量変化率 Capacitance Change	初期値の ±20% 以内 Within ±20% of the initial value.	損失角の正接 Dissipation Factor	規格値の 200% 以下 Not more than 200% of the specified value.	漏れ電流 Leakage Current	規格値以下 Not more than the specified value.							
静電容量変化率 Capacitance Change	初期値の ±20% 以内 Within ±20% of the initial value.													
損失角の正接 Dissipation Factor	規格値の 200% 以下 Not more than 200% of the specified value.													
漏れ電流 Leakage Current	規格値以下 Not more than the specified value.													
低温特性 Low Temperature Stability (インピーダンス比) Impedance Ratio (MAX)	<table border="1"> <tr> <td>定格電圧 (Vdc) Rated Voltage</td> <td>250</td> <td>275</td> <td>290</td> <td rowspan="3">(120Hz)</td> </tr> <tr> <td>Z(-25°C)/Z(+20°C)</td> <td>3</td> <td>3</td> <td>3</td> </tr> <tr> <td>Z(-40°C)/Z(+20°C)</td> <td>6</td> <td>6</td> <td>6</td> </tr> </table>	定格電圧 (Vdc) Rated Voltage	250	275	290	(120Hz)	Z(-25°C)/Z(+20°C)	3	3	3	Z(-40°C)/Z(+20°C)	6	6	6
定格電圧 (Vdc) Rated Voltage	250	275	290	(120Hz)										
Z(-25°C)/Z(+20°C)	3	3	3											
Z(-40°C)/Z(+20°C)	6	6	6											

◆呼称方法/PART NUMBER

□□□	HBX	□□□□□	M	SPA	□□	D x L
定格電圧 Rated Voltage	シリーズ名 Series	静電容量 Capacitance	静電容量許容差 Capacitance Tolerance	副記号 Option	リード加工記号 Lead Forming	ケースサイズ Case Size

◆リップル電流補正係数/MULTIPLIER FOR RIPPLE CURRENT

周波数 (Hz) Frequency	120	1k	10k	100k ≤
係数 Coefficient	0.45	0.80	1.00	1.00

◆寸法図／DIMENSIONS

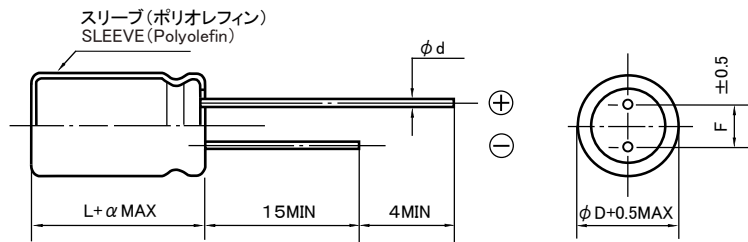

(mm)

ϕD	10	12.5	16
ϕd	0.8		
F	5.0	7.5	
α	2.0		

◆標準品一覧表／STANDARD SIZE

定格電圧 Rated Voltage (Vdc)	静電容量 Capacitance (μF)	外形寸法 Size $\phi D \times L$ (mm)	定格リプル電流 I_0 Rated ripple current I_0 (mA r.m.s./ 125°C, 100kHz)	許容リプル電流 IMAX MAX ripple current IMAX (mA r.m.s./ 125°C, 100kHz)	許容リプル電流 IMAX MAX ripple current IMAX (mA r.m.s./ 105°C, 100kHz)
250	30	12.5×20	1100	1100	1870
	36	10×30	1330	1330	2260
	43	10×35	1550	1550	2630
	43	12.5×25	1410	1410	2390
	51	10×40	1760	1760	2990
	51	16×20	1440	1440	2440
	56	12.5×30	1710	1710	2900
275	30	12.5×20	1020	1020	1730
	36	10×30	1240	1240	2100
	43	10×35	1440	1440	2440
	43	12.5×25	1310	1310	2220
	51	10×40	1640	1640	2780
	51	16×20	1350	1350	2290
	56	12.5×30	1590	1590	2700
290	24	12.5×20	830	830	1410
	30	10×30	1000	1000	1700
	36	10×35	1160	1160	1970
	36	12.5×25	1060	1060	1800
	43	10×40	1320	1320	2240
	43	16×20	1100	1100	1870
	43	12.5×30	1290	1290	2190

定格リプル電流 I_0 : 耐久性規格を満たす、連続印加可能なリプル電流。

Rated ripple current I_0 : Ripple current continuous operation within endurance lifetime.

許容リプル電流IMAX: 連続印加可能なリプル電流最大値。寿命推定時間は、寿命計算式に従う。

Maximum ripple current IMAX: Maximum ripple current continuous operation. Estimated lifetime complies with our lifetime calculation formula.

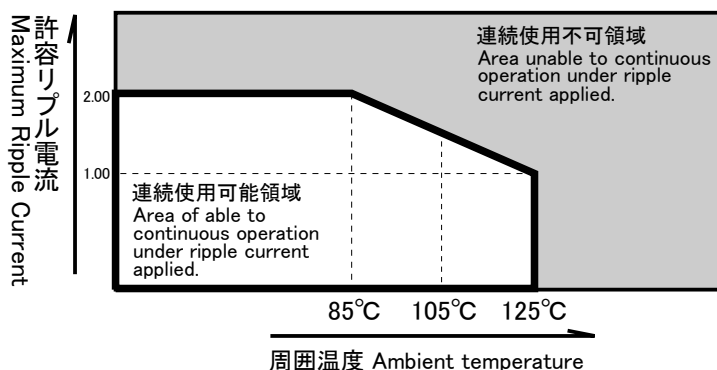

HCX series

125°C 3000時間品
Load Life: 125°C 3000 hours

- ・高リップル、低ESR 車載専用高信頼性。
High Ripple Current, Low ESR, High Reliability.
- ・高圧インバータ等のDCリンクに最適。
Suitable for DC Link of high voltage inverter.

AEC-Q200

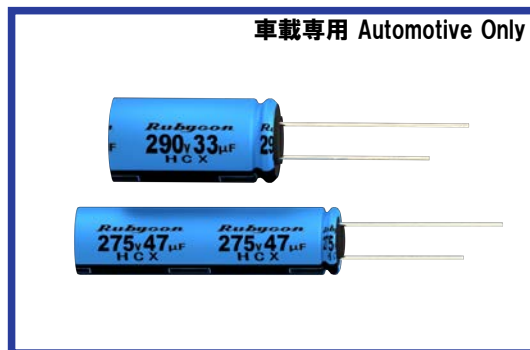

◆規格表/SPECIFICATIONS

項目 Item	特性 Characteristics													
カテゴリ温度範囲 Category Temperature Range	-40~+125°C													
定格電圧範囲 Rated Voltage Range	250~290Vdc													
静電容量許容差 Capacitance Tolerance	±20%(20°C, 120Hz)													
漏れ電流 Leakage Current (MAX)	$I=3\sqrt{CV}$ (定格電圧印加5分後) $I=3\sqrt{CV}$ (After 5 minutes application of rated voltage) I=漏れ電流(μA) C=静電容量(μF) V=定格電圧(Vdc) Leakage Current Capacitance Rated Voltage													
損失角の正接(tan δ) Dissipation Factor (MAX)	<table border="1"> <tr> <td>定格電圧 (Vdc) Rated Voltage</td> <td>250</td> <td>275</td> <td>290</td> <td rowspan="2">(20°C, 120Hz)</td> </tr> <tr> <td>tan δ</td> <td>0.15</td> <td>0.15</td> <td>0.15</td> </tr> </table>	定格電圧 (Vdc) Rated Voltage	250	275	290	(20°C, 120Hz)	tan δ	0.15	0.15	0.15				
定格電圧 (Vdc) Rated Voltage	250	275	290	(20°C, 120Hz)										
tan δ	0.15	0.15	0.15											
耐久性 Endurance	125°C中で3000時間定格電圧(リップル重畳)印加後、下記項目を満足すること。 After applying rated voltage with rated ripple current for 3000 hours at 125°C, the capacitors shall meet the following requirements.													
低温特性 Low Temperature Stability (インピーダンス比) Impedance Ratio (MAX)	<table border="1"> <tr> <td>定格電圧 (Vdc) Rated Voltage</td> <td>250</td> <td>275</td> <td>290</td> <td rowspan="3">(120Hz)</td> </tr> <tr> <td>Z(-25°C)/Z(+20°C)</td> <td>3</td> <td>3</td> <td>3</td> </tr> <tr> <td>Z(-40°C)/Z(+20°C)</td> <td>6</td> <td>6</td> <td>6</td> </tr> </table>	定格電圧 (Vdc) Rated Voltage	250	275	290	(120Hz)	Z(-25°C)/Z(+20°C)	3	3	3	Z(-40°C)/Z(+20°C)	6	6	6
定格電圧 (Vdc) Rated Voltage	250	275	290	(120Hz)										
Z(-25°C)/Z(+20°C)	3	3	3											
Z(-40°C)/Z(+20°C)	6	6	6											

◆呼称方法/PART NUMBER

□□□	HCX	□□□□□	M	SPA	□□	D x L
定格電圧 Rated Voltage	シリーズ名 Series	静電容量 Capacitance	静電容量許容差 Capacitance Tolerance	副記号 Option	リード加工記号 Lead Forming	ケースサイズ Case Size

◆リップル電流補正係数/MULTIPLIER FOR RIPPLE CURRENT

周波数 (Hz) Frequency	120	1k	10k	100k≤
係数 Coefficient	0.45	0.80	1.00	1.00

◆寸法図／DIMENSIONS

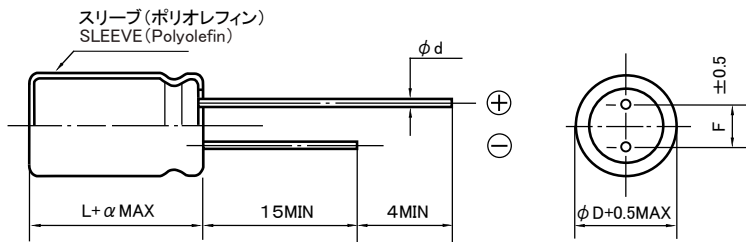

(mm)

φD	10	12.5	16
φd	0.8		
F	5.0	7.5	
α	2.0		

◆標準品一覧表／STANDARD SIZE

定格電圧 Rated Voltage (Vdc)	静電容量 Capacitance (μF)	外形寸法 Size φD×L(mm)	定格リプル電流 I ₀ Rated ripple current I ₀ (mA r.m.s./ 125°C,100kHz)	許容リプル電流 IMAX MAX ripple current IMAX(mA r.m.s./ 125°C,100kHz)	許容リプル電流 IMAX MAX ripple current IMAX (mA r.m.s./ 105°C,100kHz)
250	27	12.5×20	1780	1780	2380
	39	12.5×25	2280	2280	3050
	47	10×40	2440	2440	3260
	47	16×20	2280	2280	3050
	51	12.5×30	2770	2770	3710
275	27	12.5×20	1790	1790	2390
	39	12.5×25	2290	2290	3060
	47	10×40	2450	2450	3280
	47	16×20	2270	2270	3040
	51	12.5×30	2780	2780	3720
290	22	12.5×20	1740	1740	2330
	33	12.5×25	2240	2240	3000
	39	10×40	2390	2390	3200
	39	16×20	2240	2240	3000
	43	12.5×30	2710	2710	3630

定格リプル電流I₀: 耐久性規格を満たす、連続印加可能なリプル電流。

Rated ripple current I₀: Ripple current continuous operation within endurance lifetime.

許容リプル電流IMAX: 連続印加可能なリプル電流最大値。寿命推定時間は、寿命計算式に従う。

Maximum ripple current IMAX: Maximum ripple current continuous operation. Estimated lifetime complies with our lifetime calculation formula.

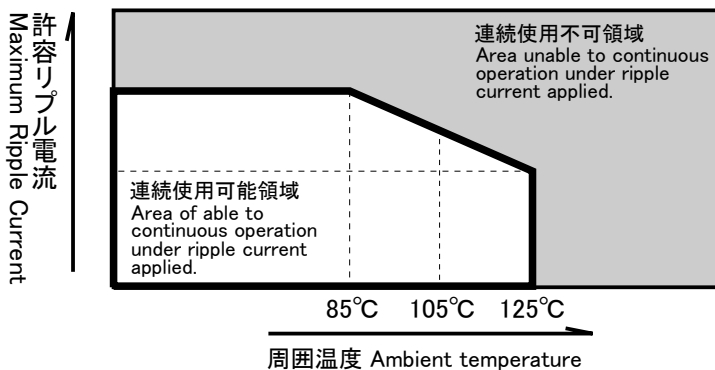

HGX series

125°C 3000時間、135°C 3000時間品
Load Life: 125°C 3000 hours, 135°C 3000 hours

・低圧インバータ等のDCリンク用に最適。
Suitable for DC Link of low voltage inverter

AEC-Q200



◆規格表/SPECIFICATIONS

項目 Item	特性 Characteristics																		
カテゴリ温度範囲 Category Temperature Range	-40~+135°C(150°C)																		
定格電圧範囲 Rated Voltage Range	25~70Vdc																		
静電容量許容差 Capacitance Tolerance	±20%(20°C, 120Hz)																		
漏れ電流 Leakage Current (MAX)	I=0.03CV又は4μAのいずれか大なる値以下(定格電圧印加1分後) I=0.03CV or 4μA whichever is greater. (After 1 minute) I=漏れ電流(μA) C=静電容量(μF) V=定格電圧(Vdc) Leakage Current Capacitance Rated Voltage																		
損失角の正接(tan δ) Dissipation Factor (MAX)	<table border="1"> <tr> <td>定格電圧 (Vdc) Rated Voltage</td> <td>25</td> <td>35</td> <td>50</td> <td>70</td> <td>(20°C, 120Hz)</td> </tr> <tr> <td>tan δ</td> <td>0.14</td> <td>0.12</td> <td>0.10</td> <td>0.10</td> <td></td> </tr> </table> <p>1000μFを越えるものは1000μF増す毎に上表の値に0.02を加えた値とする。 When capacitance is over 1000μF, tan δ shall be added 0.02 to the listed value with increase of every 1000μF.</p>	定格電圧 (Vdc) Rated Voltage	25	35	50	70	(20°C, 120Hz)	tan δ	0.14	0.12	0.10	0.10							
定格電圧 (Vdc) Rated Voltage	25	35	50	70	(20°C, 120Hz)														
tan δ	0.14	0.12	0.10	0.10															
耐久性 Endurance	<p>125°C又は135°Cにおいて3000時間(≥50Vdc:2000時間)定格電圧(定格リップル重畳)印加後、下記項目を満足すること。 After applying rated voltage with rated ripple current for 3000 hours(≥50Vdc:2000 hours) at each temperature, the capacitors shall meet the following requirements.</p> <table border="1"> <tr> <td>静電容量変化率 Capacitance Change</td> <td>初期値の±30%以内 Within ±30% of the initial value.</td> </tr> <tr> <td>損失角の正接 Dissipation Factor</td> <td>規格値の 300% 以下 Not more than 300% of the specified value.</td> </tr> <tr> <td>漏れ電流 Leakage Current</td> <td>規格値以下 Not more than the specified value.</td> </tr> </table>	静電容量変化率 Capacitance Change	初期値の±30%以内 Within ±30% of the initial value.	損失角の正接 Dissipation Factor	規格値の 300% 以下 Not more than 300% of the specified value.	漏れ電流 Leakage Current	規格値以下 Not more than the specified value.												
静電容量変化率 Capacitance Change	初期値の±30%以内 Within ±30% of the initial value.																		
損失角の正接 Dissipation Factor	規格値の 300% 以下 Not more than 300% of the specified value.																		
漏れ電流 Leakage Current	規格値以下 Not more than the specified value.																		
過温度耐性 Over temperature proof	<p>150°Cにおいて500時間定格電圧印加後、下記項目を満足すること。 After applying rated voltage for 500 hours at 150°C, the capacitors shall meet the following requirements.</p> <table border="1"> <tr> <td>静電容量変化率 Capacitance Change</td> <td>初期値の±30%以内 Within ±30% of the initial value.</td> </tr> <tr> <td>損失角の正接 Dissipation Factor</td> <td>規格値の 300% 以下 Not more than 300% of the specified value.</td> </tr> <tr> <td>漏れ電流 Leakage Current</td> <td>規格値以下 Not more than the specified value.</td> </tr> </table>	静電容量変化率 Capacitance Change	初期値の±30%以内 Within ±30% of the initial value.	損失角の正接 Dissipation Factor	規格値の 300% 以下 Not more than 300% of the specified value.	漏れ電流 Leakage Current	規格値以下 Not more than the specified value.												
静電容量変化率 Capacitance Change	初期値の±30%以内 Within ±30% of the initial value.																		
損失角の正接 Dissipation Factor	規格値の 300% 以下 Not more than 300% of the specified value.																		
漏れ電流 Leakage Current	規格値以下 Not more than the specified value.																		
低温特性 Low Temperature Stability (インピーダンス比) Impedance Ratio (MAX)	<table border="1"> <tr> <td>定格電圧 (Vdc) Rated Voltage</td> <td>25</td> <td>35</td> <td>50</td> <td>70</td> <td>(120Hz)</td> </tr> <tr> <td>Z(-25°C)/Z(+20°C)</td> <td>2</td> <td>2</td> <td>2</td> <td>2</td> <td></td> </tr> <tr> <td>Z(-40°C)/Z(+20°C)</td> <td>3</td> <td>3</td> <td>3</td> <td>3</td> <td></td> </tr> </table>	定格電圧 (Vdc) Rated Voltage	25	35	50	70	(120Hz)	Z(-25°C)/Z(+20°C)	2	2	2	2		Z(-40°C)/Z(+20°C)	3	3	3	3	
定格電圧 (Vdc) Rated Voltage	25	35	50	70	(120Hz)														
Z(-25°C)/Z(+20°C)	2	2	2	2															
Z(-40°C)/Z(+20°C)	3	3	3	3															

◆呼称方法/PART NUMBER

□□□	HGX	□□□□□	M	SPA	□□	D×L
定格電圧 Rated Voltage	シリーズ名 Series	静電容量 Capacitance	静電容量許容差 Capacitance Tolerance	副記号 Option	リード加工記号 Lead Forming	ケースサイズ Case Size

◆リップル電流補正係数/MULTIPLIER FOR RIPPLE CURRENT

周波数 (Hz) Frequency	120	1k	10k	100k≤
係数 Coefficient	0.45	0.80	1.00	1.00

◆寸法図／DIMENSIONS

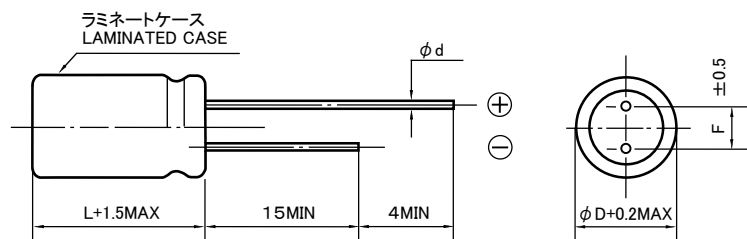

(mm)

ϕD	12.5	16	18
ϕd	0.8		
F	5.0	7.5	

◆標準品一覧表／STANDARD SIZE

定格電圧 Rated Voltage (Vdc)	静電容量 Capacitance (μF)	外形寸法 Size $\phi D \times L$ (mm)	定格リップル電流 I_o Rated ripple current I_o (mA r.m.s./100kHz)		ESR (Ω MAX / 20°C, 100kHz)	許容リップル電流 I_{MAX} MAX ripple current I_{MAX} (mA r.m.s./100kHz)		
			135°C	125°C		135°C	125°C	105°C
			25	910		12.5x20	2060	2870
	1300	12.5x25	2610	3640	0.034	2860	3700	4960
	1600	12.5x20	2060	2870	0.046	2260	2920	3910
	1600	12.5x30	3030	4230	0.029	3330	4300	5770
	1600	16x20	2320	3240	0.034	2550	3300	4420
	2000	18x20	2490	3470	0.033	2730	3520	4730
	2200	16x25	2930	4090	0.025	3210	4150	5570
	2400	12.5x25	2610	3640	0.034	2860	3700	4960
	2700	16x30	3280	4580	0.021	3610	4660	6250
	2700	18x25	3120	4360	0.025	3430	4430	5940
	3000	12.5x30	3030	4230	0.029	3330	4300	5770
	3000	16x20	2320	3240	0.034	2550	3300	4420
	3600	18x30	3460	4840	0.021	3800	4910	6590
	3900	18x20	2490	3470	0.033	2730	3520	4730
	4300	16x25	2930	4090	0.025	3210	4150	5570
	5600	16x30	3280	4580	0.021	3610	4660	6250
	5600	18x25	3120	4360	0.025	3430	4430	5940
	6800	18x30	3460	4840	0.021	3800	4910	6590
35	750	12.5x20	2060	2870	0.046	2260	2920	3910
	1000	12.5x25	2610	3640	0.034	2860	3700	4960
	1200	12.5x20	2060	2870	0.046	2260	2920	3910
	1300	12.5x30	3030	4230	0.029	3330	4300	5770
	1300	16x20	2320	3240	0.034	2550	3300	4420
	1600	12.5x25	2610	3640	0.034	2860	3700	4960
	1600	18x20	2490	3470	0.033	2730	3520	4730
	1800	16x25	2930	4090	0.025	3210	4150	5570
	2000	16x20	2320	3240	0.034	2550	3300	4420
	2200	12.5x30	3030	4230	0.029	3330	4300	5770
	2400	16x30	3280	4580	0.021	3610	4660	6250
	2400	18x25	3120	4360	0.025	3430	4430	5940
	2700	18x20	2490	3470	0.033	2730	3520	4730
	3000	16x25	2930	4090	0.025	3210	4150	5570
	3000	18x30	3460	4840	0.021	3800	4910	6590
	3600	16x30	3280	4580	0.021	3610	4660	6250
	3600	18x25	3120	4360	0.025	3430	4430	5940
	4700	18x30	3460	4840	0.021	3800	4910	6590

◆標準品一覧表／STANDARD SIZE

定格電圧 Rated Voltage (Vdc)	静電容量 Capacitance (μ F)	外形寸法 Size ϕ D×L(mm)	定格リップル電流 I_0 Rated ripple current I_0 (mA r.m.s./100kHz)		ESR (Ω MAX / 20°C,100kHz)	許容リップル電流 I_{MAX} MAX ripple current I_{MAX} (mA r.m.s./100kHz)		
			135°C	125°C		135°C	125°C	105°C
			50	510		12.5×20	1530	2280
620	12.5×20	1490		2220	0.076	1800	2330	3130
680	12.5×25	1950		2900	0.052	2360	3050	4090
910	12.5×25	1890		2820	0.055	2290	2960	3980
910	12.5×30	2320		3460	0.042	2810	3630	4880
910	16×20	1890		2820	0.049	2290	2960	3980
1100	12.5×30	2250		3370	0.044	2730	3530	4740
1100	16×20	1860		2780	0.051	2260	2920	3910
1100	18×20	2060		3070	0.047	2490	3220	4320
1300	16×25	2390		3570	0.036	2900	3750	5030
1300	18×20	2040		3050	0.047	2470	3200	4290
1600	16×25	2350		3510	0.037	2860	3690	4950
1600	16×30	2840		4240	0.029	3440	4450	5970
1600	18×25	2600		3880	0.034	3150	4070	5470
2000	16×30	2790		4170	0.030	3390	4370	5870
2000	18×25	2580		3850	0.034	3130	4040	5420
2000	18×30	3080		4600	0.027	3740	4830	6480
2400	18×30	3050		4560	0.028	3700	4780	6420
70	240	12.5×20	1340	2000	0.093	1630	2100	2820
	360	12.5×20	1300	1940	0.099	1580	2040	2740
	360	12.5×25	1710	2550	0.067	2070	2680	3600
	430	16×20	1690	2530	0.062	2050	2650	3560
	470	12.5×30	2040	3040	0.054	2470	3190	4290
	510	12.5×25	1660	2470	0.072	2010	2600	3490
	560	18×20	1860	2780	0.057	2260	2920	3920
	620	12.5×30	1980	2950	0.057	2400	3100	4150
	620	16×20	1660	2480	0.064	2010	2600	3490
	620	16×25	2150	3200	0.045	2600	3360	4510
	750	18×20	1840	2750	0.058	2230	2880	3870
	820	16×30	2550	3800	0.036	3090	3990	5360
	820	18×25	2350	3510	0.042	2860	3690	4950
	910	16×25	2100	3140	0.047	2550	3300	4420
	1000	18×30	2790	4170	0.033	3390	4380	5870
	1100	16×30	2500	3730	0.038	3030	3910	5250
	1100	18×25	2330	3470	0.042	2820	3650	4890
	1300	18×30	2760	4120	0.034	3350	4330	5810

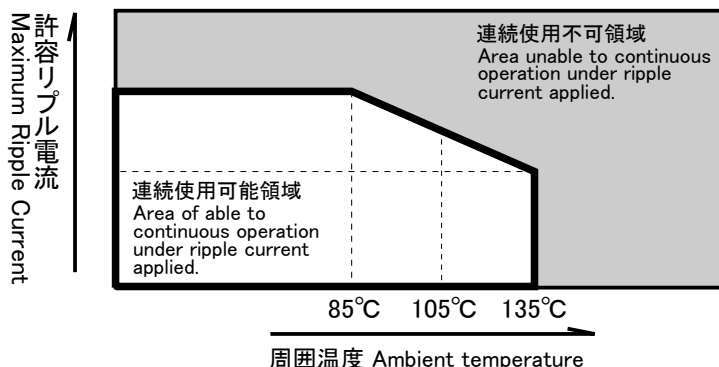

定格リップル電流 I_0 : 耐久性規格を満たす、連続印加可能なリップル電流。
Rated ripple current I_0 : Ripple current continuous operation within endurance lifetime.

許容リップル電流 I_{MAX} : 連続印加可能なリップル電流最大値。寿命推定時間は、寿命計算式に従う。
Maximum ripple current I_{MAX} : Maximum ripple current continuous operation. Estimated lifetime complies with our lifetime calculation formula.

JXF series

105°C 6000~8000時間品 低インピーダンス品 広温度範囲品
105°C 6000~8000 hours, Low Impedance, Wide Temperature Range

AEC-Q200



◆規格表/SPECIFICATIONS

項目 Item	特性 Characteristics																		
カテゴリ温度範囲 Category Temperature Range	-55~+105°C																		
定格電圧範囲 Rated Voltage Range	16~100Vdc																		
静電容量許容差 Capacitance Tolerance	±20%(20°C, 120Hz)																		
漏れ電流 Leakage Current (MAX)	I=0.01CV又は3µAのいずれか大なる値以下(定格電圧印加2分後) I=0.01CV or 3µA whichever is greater. (After 2 minutes) I=漏れ電流(µA) C=静電容量(µF) V=定格電圧(Vdc) Leakage Current Capacitance Rated Voltage																		
損失角の正接(tan δ) Dissipation Factor (MAX)	<table border="1"> <tr> <td>定格電圧(Vdc) Rated Voltage</td> <td>16</td> <td>25</td> <td>35</td> <td>50</td> <td>63</td> <td>80</td> <td>100</td> <td>(20°C, 120Hz)</td> </tr> <tr> <td>tan δ</td> <td>0.16</td> <td>0.14</td> <td>0.12</td> <td>0.10</td> <td>0.09</td> <td>0.09</td> <td>0.08</td> <td></td> </tr> </table> <p>1000µFを越えるものは1000µF増す毎に上表の値に0.02を加えた値とする。 When capacitance is over 1000µF, tan δ shall be added 0.02 to the listed value with increase of every 1000µF.</p>	定格電圧(Vdc) Rated Voltage	16	25	35	50	63	80	100	(20°C, 120Hz)	tan δ	0.16	0.14	0.12	0.10	0.09	0.09	0.08	
定格電圧(Vdc) Rated Voltage	16	25	35	50	63	80	100	(20°C, 120Hz)											
tan δ	0.16	0.14	0.12	0.10	0.09	0.09	0.08												
耐久性 Endurance	<p>105°C中で右表の時間定格電圧(リップル重畳)印加後、下記項目を満足すること。 After applying rated voltage with rated ripple current for specified time at 105°C, the capacitors shall meet the following requirements.</p> <table border="1"> <tr> <td>静電容量変化率 Capacitance Change</td> <td>初期値の±30%以内 Within ±30% of the initial value.</td> <td>ケースサイズ Case Size</td> <td>時間(hrs) Time(hrs)</td> </tr> <tr> <td>損失角の正接 Dissipation Factor</td> <td>規格値の300%以下 Not more than 300% of the specified value.</td> <td>φD ≤ 10</td> <td>6000</td> </tr> <tr> <td>漏れ電流 Leakage Current</td> <td>規格値以下 Not more than the specified value.</td> <td>φD ≥ 12.5</td> <td>8000</td> </tr> </table>	静電容量変化率 Capacitance Change	初期値の±30%以内 Within ±30% of the initial value.	ケースサイズ Case Size	時間(hrs) Time(hrs)	損失角の正接 Dissipation Factor	規格値の300%以下 Not more than 300% of the specified value.	φD ≤ 10	6000	漏れ電流 Leakage Current	規格値以下 Not more than the specified value.	φD ≥ 12.5	8000						
静電容量変化率 Capacitance Change	初期値の±30%以内 Within ±30% of the initial value.	ケースサイズ Case Size	時間(hrs) Time(hrs)																
損失角の正接 Dissipation Factor	規格値の300%以下 Not more than 300% of the specified value.	φD ≤ 10	6000																
漏れ電流 Leakage Current	規格値以下 Not more than the specified value.	φD ≥ 12.5	8000																
低温特性 Low Temperature Stability (インピーダンス比) Impedance Ratio (MAX)	<table border="1"> <tr> <td>定格電圧(Vdc) Rated Voltage</td> <td>16</td> <td>25</td> <td>35</td> <td>50</td> <td>63</td> <td>80</td> <td>100</td> <td>(120Hz)</td> </tr> <tr> <td>Z(-55°C)/Z(+20°C)</td> <td>3</td> <td>3</td> <td>3</td> <td>3</td> <td>3</td> <td>3</td> <td>3</td> <td></td> </tr> </table>	定格電圧(Vdc) Rated Voltage	16	25	35	50	63	80	100	(120Hz)	Z(-55°C)/Z(+20°C)	3	3	3	3	3	3	3	
定格電圧(Vdc) Rated Voltage	16	25	35	50	63	80	100	(120Hz)											
Z(-55°C)/Z(+20°C)	3	3	3	3	3	3	3												

◆呼称方法/PART NUMBER

JXF M D x L
 定格電圧 シリーズ名 静電容量 静電容量許容差 副記号 リード加工記号 ケースサイズ
 Rated Voltage Series Capacitance Capacitance Tolerance Option Lead Forming Case Size

◆リップル電流補正係数/
MULTIPLIER FOR RIPPLE CURRENT

周波数 (Hz) Frequency	120	1k	10k	100k ≤
68~270µF	0.50	0.73	0.92	1.00
300~680µF	0.55	0.77	0.94	1.00
820~1800µF	0.60	0.80	0.96	1.00
2200~10000µF	0.70	0.85	0.98	1.00

◆副記号/OPTION

EFC : PETスリーブ PET Sleeve

◆寸法図／DIMENSIONS

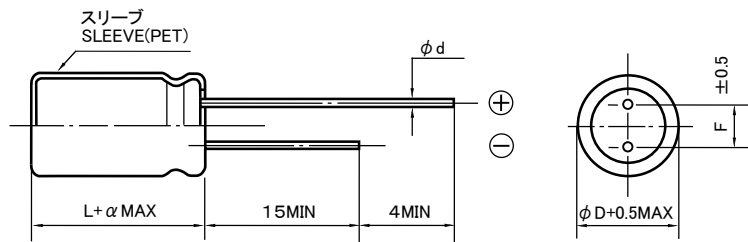

(mm)				
ϕD	10	12.5	16	18
ϕd	0.6		0.8	
F	5.0		7.5	
α	2.0			

◆標準品一覧表／STANDARD SIZE

Rated Ripple Current (mA r.m.s./105°C, 100kHz), Impedance (Ω MAX/100kHz)

定格電圧 Rated Voltage (Vdc)	静電容量 Capacitance (μF)	外形寸法 Size φD × L (mm)	定格リプル 電流 Rated Ripple	インピーダンス (Ω MAX) Impedance	
				20°C	-10°C
16	1000	10×16	1180	0.061	0.122
	1500	10×20	1490	0.045	0.090
	1800	10×25	1710	0.037	0.074
	2200	12.5×20	1780	0.038	0.076
	3300	12.5×25	2170	0.030	0.060
	3900	12.5×30	2540	0.025	0.050
	3900	16×20	2210	0.028	0.056
	5600	16×25	2620	0.022	0.044
	5600	18×20	2490	0.028	0.056
	6800	16×30	3060	0.019	0.038
	8200	18×25	2790	0.020	0.040
	10000	18×30	3240	0.018	0.036
25	680	10×16	1180	0.061	0.122
	1000	10×20	1490	0.045	0.090
	1200	10×25	1710	0.037	0.074
	1500	12.5×20	1780	0.038	0.076
	2200	12.5×25	2170	0.030	0.060
	2700	12.5×30	2540	0.025	0.050
	2700	16×20	2210	0.028	0.056
	3300	18×20	2490	0.028	0.056
	3900	16×25	2620	0.022	0.044
	4700	16×30	3060	0.019	0.038
	4700	18×25	2790	0.020	0.040
	5600	18×30	3240	0.018	0.036

定格電圧 Rated Voltage (Vdc)	静電容量 Capacitance (μF)	外形寸法 Size φD × L (mm)	定格リプル 電流 Rated Ripple	インピーダンス (Ω MAX) Impedance	
				20°C	-10°C
35	470	10×16	1180	0.061	0.122
	680	10×20	1490	0.045	0.090
	820	10×25	1710	0.037	0.074
	1000	12.5×20	1780	0.038	0.076
	1200	12.5×25	2170	0.030	0.060
	1800	12.5×30	2540	0.025	0.050
	1800	16×20	2210	0.028	0.056
	2200	16×25	2620	0.022	0.044
	2200	18×20	2490	0.028	0.056
	3300	16×30	3060	0.019	0.038
	3300	18×25	2790	0.020	0.040
	3900	18×30	3240	0.018	0.036
50	180	10×16	850	0.100	0.200
	270	10×20	1050	0.075	0.150
	330	10×25	1250	0.057	0.114
	390	12.5×20	1480	0.059	0.118
	560	12.5×25	1840	0.044	0.088
	680	12.5×30	2220	0.036	0.072
	820	16×20	1840	0.044	0.088
	1200	16×25	2240	0.032	0.064
	1200	18×20	2150	0.041	0.082
	1500	16×30	2700	0.026	0.052
	1500	18×25	2610	0.029	0.058
	2200	18×30	3000	0.024	0.048

◆標準品一覧表／STANDARD SIZE

Rated Ripple Current (mA r.m.s./105°C, 100kHz), Impedance (Ω MAX/100kHz)

定格電圧 Rated Voltage (Vdc)	静電容量 Capacitance (μF)	外形寸法 Size φD×L (mm)	定格リプル 電流 Rated Ripple	インピーダンス (Ω MAX) Impedance	
				20°C	-10°C
63	120	10×16	600	0.160	0.32
	180	10×20	890	0.120	0.24
	220	10×25	1050	0.090	0.18
	330	12.5×20	1290	0.085	0.17
	390	12.5×25	1720	0.066	0.132
	470	12.5×30	2090	0.052	0.104
	560	16×20	1770	0.059	0.118
	820	16×25	2160	0.047	0.094
	820	18×20	2290	0.055	0.110
	1000	16×30	2670	0.037	0.074
	1000	18×25	2590	0.040	0.080
	1500	18×30	2950	0.032	0.064
80	100	10×16	550	0.330	0.81
	150	10×20	780	0.240	0.59
	180	10×25	970	0.190	0.47
	180	12.5×20	1120	0.165	0.39
	270	12.5×25	1420	0.120	0.28
	390	12.5×30	1690	0.097	0.23
	390	16×20	1560	0.110	0.26
	470	18×20	1660	0.090	0.19
	560	16×25	1980	0.081	0.19
	680	16×30	2350	0.064	0.15
	680	18×25	2100	0.070	0.15
	820	18×30	2490	0.058	0.13

定格電圧 Rated Voltage (Vdc)	静電容量 Capacitance (μF)	外形寸法 Size φD×L (mm)	定格リプル 電流 Rated Ripple	インピーダンス (Ω MAX) Impedance	
				20°C	-10°C
100	68	10×16	550	0.330	0.81
	100	10×20	780	0.240	0.59
	120	10×25	970	0.190	0.47
	120	12.5×20	1120	0.165	0.39
	180	12.5×25	1420	0.120	0.28
	220	12.5×30	1690	0.097	0.23
	270	16×20	1560	0.110	0.26
	330	16×25	1980	0.081	0.19
	330	18×20	1660	0.090	0.19
	470	16×30	2350	0.064	0.15
	470	18×25	2100	0.070	0.15
	560	18×30	2490	0.058	0.13

LEX series

125°C 3000~5000時間品
Load Life: 125°C 3000~5000 hours

・LED照明用電源回路に最適。
For LED Lighting.

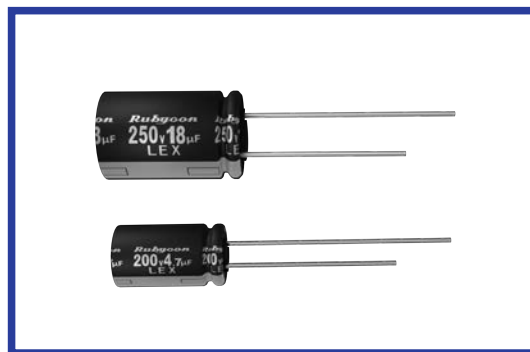

◆規格表/SPECIFICATIONS

項目 Item	特性 Characteristics															
カテゴリ温度範囲 Category Temperature Range	-40~+125°C															
定格電圧範囲 Rated Voltage Range	160~450Vdc															
静電容量許容差 Capacitance Tolerance	±20%(20°C, 120Hz)															
漏れ電流 Leakage Current (MAX)	CV ≤ 1000	CV > 1000														
	I=0.1CV+40 μA以下(1分値) I=0.1CV+40 μA (1minute) I=0.03CV+15 μA以下(5分値) I=0.03CV+15 μA (5minutes)	I=0.04CV+100 μA以下(1分値) I=0.04CV+100 μA (1minute) I=0.02CV+25 μA以下(5分値) I=0.02CV+25 μA (5minutes)														
I=漏れ電流(μA) Leakage Current C=静電容量(μF) Capacitance V=定格電圧(Vdc) Rated Voltage																
損失角の正接(tan δ) Dissipation Factor (MAX)	定格電圧 (Vdc) Rated Voltage	160 200 250 400 450														
	tan δ	0.24 0.24 0.24 0.24 0.24														
(20°C, 120Hz)																
耐久性 Endurance	125°C中で右表の時間定格電圧(リップル重畳)印加後、下記項目を満足すること。 After applying rated voltage with rated ripple current for specified time at 125°C, the capacitors shall meet the following requirements.															
	静電容量変化率 Capacitance Change	初期値の±30%以内 Within ±30% of the initial value.														
	損失角の正接 Dissipation Factor	規格値の300%以下 Not more than 300% of the specified value.														
	漏れ電流 Leakage Current	規格値以下 Not more than the specified value.														
		<table border="1"> <thead> <tr> <th rowspan="2">ケースサイズ Case Size</th> <th colspan="2">Time(hrs)</th> </tr> <tr> <th>160~400Vdc</th> <th>450Vdc</th> </tr> </thead> <tbody> <tr> <td>6.3x11, 8x9, 10x9</td> <td>4000</td> <td>3000</td> </tr> <tr> <td>8x11.5</td> <td>5000</td> <td>3000</td> </tr> <tr> <td>10x12.5, 10x16, 10x20 φD ≥ 12.5</td> <td>5000</td> <td>5000</td> </tr> </tbody> </table>	ケースサイズ Case Size	Time(hrs)		160~400Vdc	450Vdc	6.3x11, 8x9, 10x9	4000	3000	8x11.5	5000	3000	10x12.5, 10x16, 10x20 φD ≥ 12.5	5000	5000
ケースサイズ Case Size	Time(hrs)															
	160~400Vdc	450Vdc														
6.3x11, 8x9, 10x9	4000	3000														
8x11.5	5000	3000														
10x12.5, 10x16, 10x20 φD ≥ 12.5	5000	5000														
低温特性 Low Temperature Stability (インピーダンス比) Impedance Ratio (MAX)	定格電圧 (Vdc) Rated Voltage	160 200 250 400 450														
	Z(-25°C)/Z(+20°C)	3 3 6 6 6														
	Z(-40°C)/Z(+20°C)	8 8 10 12 12														
(120Hz)																

◆呼称方法/PART NUMBER

□□□ LEX □□□□□ M □□□ □□ D x L
 定格電圧 シリーズ名 静電容量 静電容量許容差 副記号 リード加工記号 ケースサイズ
 Rated Voltage Series Capacitance Capacitance Tolerance Option Lead Forming Case Size

◆リップル電流補正係数/
MULTIPLIER FOR RIPPLE CURRENT

Frequency (Hz)	120	1k	10k	100k ≤
1~5.6 μF	1.0	1.6	1.8	2.0
6.8~18 μF	1.0	1.5	1.7	1.9
22~56 μF	1.0	1.4	1.6	1.8

◆副記号/OPTION

EFC : PETスリーブ PET Sleeve

◆寸法図／DIMENSIONS

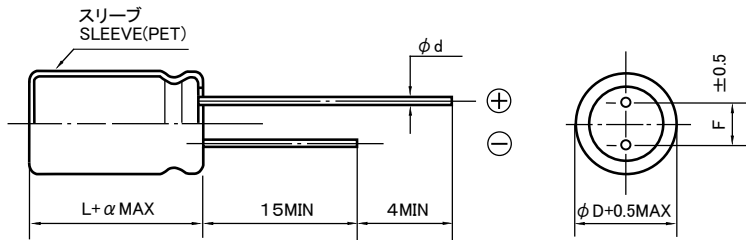

(mm)						
φD	6.3	8	10	12.5	16	18
φd	0.5	0.6		0.8		
F	2.5	3.5	5.0	7.5		
α	2.0					

◆標準品一覧表／STANDARD SIZE

Rated Ripple Current (mA r.m.s./125°C)

定格電圧 Rated Voltage (Vdc)	静電容量 Capacitance (μF)	外形寸法 Size φD×L (mm)	定格リプル電流 Rated Ripple	
			120Hz	100kHz
160	5.6	6.3×11	52	104
	10	8×9	70	133
	15	8×11.5	92	174
		10×9	95	180
	22	10×12.5	121	217
	33	10×16	158	284
200	2.2	6.3×11	36	72
	3.3	6.3×11	42	84
	4.7	6.3×11	49	98
	5.6	8×9	56	112
	6.8	8×9	62	117
	8.2	8×9	66	125
	10	8×11.5	80	152
	12	10×9	88	167
	18	10×12.5	113	214
	27	10×16	149	268
250	1.8	6.3×11	33	66
	2.2	6.3×11	36	72
	3.3	6.3×11	42	84
	4.7	8×9	53	106
	5.6	8×11.5	56	112
	6.8	8×11.5	68	129
	8.2	10×9	76	144
	10	10×12.5	83	157
	12	10×12.5	97	184
	18	10×16	127	241

定格電圧 Rated Voltage (Vdc)	静電容量 Capacitance (μF)	外形寸法 Size φD×L (mm)	定格リプル電流 Rated Ripple	
			120Hz	100kHz
400	1	6.3×11	24	48
	1.2	8×9	28	56
	1.5	8×9	30	60
	1.8	8×9	33	66
	2.2	8×9	36	72
		8×11.5	40	80
	2.7	8×11.5	43	86
	3.3	8×11.5	47	94
		10×9	48	96
	3.9	10×12.5	57	114
4.7	10×12.5	61	122	
6.8	10×16	85	161	
450	1	6.3×11	24	48
	1.5	8×9	30	60
	1.8	8×11.5	38	76
	2.2	10×9	40	80
	2.7	10×9	42	84
	3.3	10×12.5	52	104
	4.7	10×16	68	136
	6.8	10×20	88	167
	10	12.5×20	110	209
	15	12.5×25	150	285
	18	12.5×25	160	304
	22	16×20	210	378
	27	16×25	250	450
	33	16×25	280	504
		18×20	270	486
	39	16×31.5	330	561
47	18×25	350	630	
56	18×31.5	410	738	

LLE series

105°C 12000~20000時間品
Load Life: 105°C 12000~20000 hours

•LED照明用電源回路に最適。
For LED Lighting.

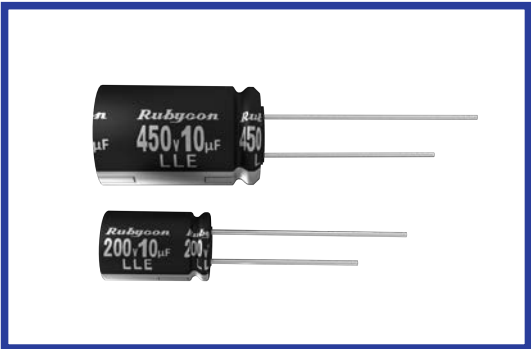

◆規格表/SPECIFICATIONS

項目 Item	特性 Characteristics			
カテゴリ温度範囲 Category Temperature Range	-40~+105°C	-25~+105°C		
定格電圧範囲 Rated Voltage Range	160~400Vdc	450Vdc		
静電容量許容差 Capacitance Tolerance	±20%(20°C, 120Hz)			
漏れ電流 Leakage Current (MAX)	CV ≤ 1000	CV > 1000	I = 漏れ電流(µA) Leakage Current C = 静電容量(µF) Capacitance V = 定格電圧(Vdc) Rated Voltage	
	I=0.1CV+40µA以下(1分値) I=0.1CV+40µA (1minute) I=0.03CV+15µA以下(5分値) I=0.03CV+15µA (5minutes)	I=0.04CV+100µA以下(1分値) I=0.04CV+100µA (1minute) I=0.02CV+25µA以下(5分値) I=0.02CV+25µA (5minutes)		
損失角の正接(tan δ) Dissipation Factor (MAX)	定格電圧 (Vdc) Rated Voltage	160 200 250 400 450	(20°C, 120Hz)	
	tan δ	0.24 0.24 0.24 0.24 0.24		
耐久性 Endurance	105°C中で右表の時間定格電圧(リップル重畳)印加後、下記項目を満足すること。 After applying rated voltage with rated ripple current for specified time at 105°C, the capacitors shall meet the following requirements.			
	静電容量変化率 Capacitance Change	初期値の±30%以内 Within ±30% of the initial value.		ケースサイズ Case Size
	損失角の正接 Dissipation Factor	規格値の 300% 以下 Not more than 300% of the specified value.		時間(hrs) Time(hrs)
	漏れ電流 Leakage Current	規格値以下 Not more than the specified value.		10×16, 10×20 φD ≥ 12.5
低温特性 Low Temperature Stability (インピーダンス比) Impedance Ratio (MAX)	定格電圧 (Vdc) Rated Voltage	160 200 250 400 450	(120Hz)	
	Z(-25°C)/Z(+20°C)	3 3 3 6 6		
	Z(-40°C)/Z(+20°C)	8 8 8 10 -		

◆呼称方法/PART NUMBER

LLE M D x L
 定格電圧 シリーズ名 静電容量 静電容量許容差 副記号 リード加工記号 ケースサイズ
 Rated Voltage Series Capacitance Capacitance Tolerance Option Lead Forming Case Size

◆副記号/OPTION

EFC : PETスリーブ PET Sleeve

◆リップル電流補正係数/MULTIPLIER FOR RIPPLE CURRENT

160~400Vdc

Frequency (Hz)	120	1k	10k	100k ≤
1~5.6 µF	1.0	1.6	1.8	2.0
6.8~18 µF	1.0	1.5	1.7	1.9
22~33 µF	1.0	1.4	1.6	1.8

450Vdc

Frequency (Hz)	120	1k	10k	100k ≤
4.7~15 µF	0.3	0.6	0.9	1.0
22~68 µF	0.4	0.7	0.9	1.0

◆寸法図／DIMENSIONS

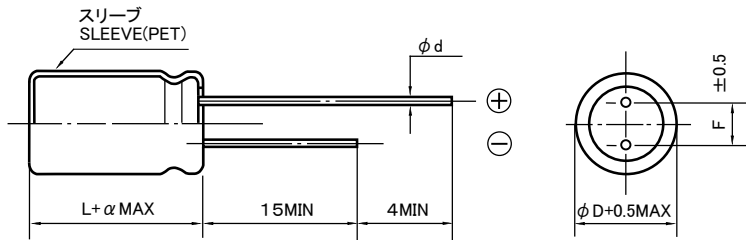

	(mm)					
φD	6.3	8	10	12.5	16	18
φd	0.5	0.6		0.8		
F	2.5	3.5	5.0	7.5		
α	2.0					

◆標準品一覧表／STANDARD SIZE

定格電圧 Rated Voltage (Vdc)	静電容量 Capacitance (μF)	外形寸法 Size φD×L (mm)	定格リプル電流 Rated Ripple	
			120Hz	100kHz
160	5.6	6.3×11	52	104
	10	8×9	70	133
	15	8×11.5	92	174
		10×9	95	180
	22	10×12.5	121	217
	33	10×16	158	284
200	2.2	6.3×11	36	72
	3.3	6.3×11	42	84
	4.7	6.3×11	49	98
	5.6	8×9	56	112
	6.8	8×9	62	117
	8.2	8×9	66	125
	10	8×11.5	80	152
	12	10×9	88	167
	18	10×12.5	113	214
	27	10×16	149	268
250	1.8	6.3×11	33	66
	2.2	6.3×11	36	72
	3.3	6.3×11	42	84
	4.7	8×9	53	106
	5.6	8×11.5	62	124
	6.8	8×11.5	68	129
	8.2	10×9	76	144
	10	10×12.5	90	171
	12	10×12.5	97	184
	18	10×16	127	241

Rated Ripple Current (mA r.m.s./105°C)

定格電圧 Rated Voltage (Vdc)	静電容量 Capacitance (μF)	外形寸法 Size φD×L (mm)	定格リプル電流 Rated Ripple	
			120Hz	100kHz
400	1	6.3×11	24	48
	1.2	8×9	28	56
	1.5	8×9	30	60
	1.8	8×9	33	66
	2.2	8×9	36	72
		8×11.5	40	80
	2.7	8×11.5	43	86
	3.3	8×11.5	47	94
		10×9	48	96
	3.9	10×12.5	57	114
4.7	10×12.5	61	122	
6.8	10×16	85	161	
450	4.7	10×16	54	180
		10×20	66	220
	6.8	10×20	84	280
	8.2	10×20	84	280
	10	12.5×20	135	450
	15	12.5×25	180	600
	22	12.5×25	240	600
		16×20	292	730
	33	16×25	392	980
		18×20	312	780
47	18×25	480	1200	
68	18×31.5	520	1300	

RX30 series

130°C 1000~4000時間品
Load Life : 130°C 1000~4000 hours

・車載機器やLED照明に最適
For Automotive and LED Lighting applications

AEC-Q200

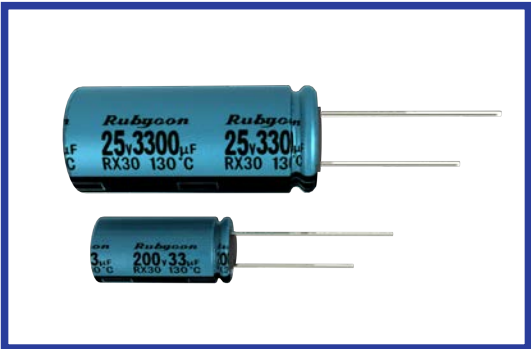

◆規格表／SPECIFICATIONS

項目 Item	特性 Characteristics																																									
カテゴリ温度範囲 Category Temperature Range	-40~+130°C	-25~+130°C																																								
定格電圧範囲 Rated Voltage Range	10~100Vdc	200,400Vdc																																								
静電容量許容差 Capacitance Tolerance	±20%(20°C, 120Hz)																																									
漏れ電流 Leakage Current (MAX)	I=0.01CV又は3µAのいずれか大なる値以下 (定格電圧印加2分後) I=0.01CV or 3µA whichever is greater. (After 2 minutes)	<table border="1"> <tr> <th>CV ≤ 1000</th> <th>CV > 1000</th> </tr> <tr> <td>I=0.1CV+40µA以下(1分値) I=0.1CV+40µA (1minute)</td> <td>I=0.04CV+100µA以下(1分値) I=0.04CV+100µA (1minute)</td> </tr> <tr> <td>I=0.03CV+15µA以下(5分値) I=0.03CV+15µA (5minutes)</td> <td>I=0.02CV+25µA以下(5分値) I=0.02CV+25µA (5minutes)</td> </tr> </table>	CV ≤ 1000	CV > 1000	I=0.1CV+40µA以下(1分値) I=0.1CV+40µA (1minute)	I=0.04CV+100µA以下(1分値) I=0.04CV+100µA (1minute)	I=0.03CV+15µA以下(5分値) I=0.03CV+15µA (5minutes)	I=0.02CV+25µA以下(5分値) I=0.02CV+25µA (5minutes)																																		
	CV ≤ 1000	CV > 1000																																								
I=0.1CV+40µA以下(1分値) I=0.1CV+40µA (1minute)	I=0.04CV+100µA以下(1分値) I=0.04CV+100µA (1minute)																																									
I=0.03CV+15µA以下(5分値) I=0.03CV+15µA (5minutes)	I=0.02CV+25µA以下(5分値) I=0.02CV+25µA (5minutes)																																									
I=漏れ電流(µA) Leakage Current C=静電容量(µF) Capacitance V=定格電圧(Vdc) Rated Voltage																																										
損失角の正接 (tan δ) Dissipation Factor (MAX)	<table border="1"> <tr> <th>定格電圧 (Vdc) Rated Voltage</th> <th>10</th> <th>16</th> <th>25</th> <th>35</th> <th>50</th> <th>63</th> <th>100</th> <th>200</th> <th>400</th> </tr> <tr> <td>(20°C, 120Hz)</td> <td>0.20</td> <td>0.16</td> <td>0.14</td> <td>0.12</td> <td>0.10</td> <td>0.09</td> <td>0.08</td> <td>0.15</td> <td>0.20</td> </tr> </table>		定格電圧 (Vdc) Rated Voltage	10	16	25	35	50	63	100	200	400	(20°C, 120Hz)	0.20	0.16	0.14	0.12	0.10	0.09	0.08	0.15	0.20																				
	定格電圧 (Vdc) Rated Voltage	10	16	25	35	50	63	100	200	400																																
(20°C, 120Hz)	0.20	0.16	0.14	0.12	0.10	0.09	0.08	0.15	0.20																																	
1000µFを越えるものは1000µF増す毎に上表の値に0.02を加えた値とする。 When capacitance is over 1000µF, tan δ shall be added 0.02 to the listed value with increase of every 1000µF.																																										
耐久性 Endurance	130°C中で右表の時間定格電圧(リップル重畳)印加後、下記項目を満足すること。 After applying rated voltage with rated ripple current for specified time at 130°C, the capacitors shall meet the following requirements.																																									
	<table border="1"> <tr> <th></th> <th>10~100Vdc</th> <th>200,400Vdc</th> <th rowspan="2">ケースサイズ Case Size</th> <th colspan="2">時間(hrs) Time(hrs)</th> </tr> <tr> <th>静電容量変化率 Capacitance Change</th> <td>初期値の±30%以内 Within ±30% of the initial value.</td> <td>初期値の±20%以内 Within ±20% of the initial value.</td> <td>10~100Vdc</td> <td>200,400Vdc</td> </tr> <tr> <th>損失角の正接 Dissipation Factor</th> <td>規格値の300%以下 Not more than 300% of the specified value.</td> <td>規格値の200%以下 Not more than 200% of the specified value.</td> <td>φD=6.3</td> <td>-</td> <td>1000</td> </tr> <tr> <th rowspan="2">漏れ電流 Leakage Current</th> <td colspan="2" rowspan="2">規格値以下 Not more than the specified value.</td> <td>φD=8,10</td> <td>2000</td> <td>2000</td> </tr> <tr> <td>φD ≥ 12.5</td> <td>4000</td> <td>-</td> </tr> </table>			10~100Vdc	200,400Vdc	ケースサイズ Case Size	時間(hrs) Time(hrs)		静電容量変化率 Capacitance Change	初期値の±30%以内 Within ±30% of the initial value.	初期値の±20%以内 Within ±20% of the initial value.	10~100Vdc	200,400Vdc	損失角の正接 Dissipation Factor	規格値の300%以下 Not more than 300% of the specified value.	規格値の200%以下 Not more than 200% of the specified value.	φD=6.3	-	1000	漏れ電流 Leakage Current	規格値以下 Not more than the specified value.		φD=8,10	2000	2000	φD ≥ 12.5	4000	-														
		10~100Vdc	200,400Vdc	ケースサイズ Case Size	時間(hrs) Time(hrs)																																					
	静電容量変化率 Capacitance Change	初期値の±30%以内 Within ±30% of the initial value.	初期値の±20%以内 Within ±20% of the initial value.		10~100Vdc	200,400Vdc																																				
損失角の正接 Dissipation Factor	規格値の300%以下 Not more than 300% of the specified value.	規格値の200%以下 Not more than 200% of the specified value.	φD=6.3	-	1000																																					
漏れ電流 Leakage Current	規格値以下 Not more than the specified value.		φD=8,10	2000	2000																																					
			φD ≥ 12.5	4000	-																																					
低温特性 Low Temperature Stability (インピーダンス比) Impedance Ratio (MAX)	<table border="1"> <tr> <th>定格電圧 (Vdc) Rated Voltage</th> <th>10</th> <th>16</th> <th>25</th> <th>35</th> <th>50</th> <th>63</th> <th>100</th> <th>200</th> <th>400</th> </tr> <tr> <td>(120Hz)</td> <td>3</td> <td>2</td> <td>2</td> <td>2</td> <td>2</td> <td>2</td> <td>2</td> <td>3</td> <td>6</td> </tr> <tr> <td>Z(-25°C)/Z(+20°C)</td> <td>6</td> <td>4</td> <td>3</td> <td>3</td> <td>3</td> <td>3</td> <td>3</td> <td>-</td> <td>-</td> </tr> <tr> <td>Z(-40°C)/Z(+20°C)</td> <td></td> <td></td> <td></td> <td></td> <td></td> <td></td> <td></td> <td></td> <td></td> </tr> </table>		定格電圧 (Vdc) Rated Voltage	10	16	25	35	50	63	100	200	400	(120Hz)	3	2	2	2	2	2	2	3	6	Z(-25°C)/Z(+20°C)	6	4	3	3	3	3	3	-	-	Z(-40°C)/Z(+20°C)									
	定格電圧 (Vdc) Rated Voltage	10	16	25	35	50	63	100	200	400																																
	(120Hz)	3	2	2	2	2	2	2	3	6																																
Z(-25°C)/Z(+20°C)	6	4	3	3	3	3	3	-	-																																	
Z(-40°C)/Z(+20°C)																																										

◆呼称方法／PART NUMBER

□□□ RX30 □□□□□ M □□□ □□ D x L
 定格電圧 シリーズ名 静電容量 静電容量許容差 副記号 リード加工記号 ケースサイズ
 Rated Voltage Series Capacitance Capacitance Tolerance Option Lead Forming Case Size

◆副記号／OPTION

標準品はブランクです。 Standard item is blank.

◆リップル電流補正係数／MULTIPLIER FOR RIPPLE CURRENT

10~100Vdc						200,400Vdc							
Frequency (Hz)		60(50)	120	1k	10k	100k ≤	Frequency (Hz)		120	1k	10k	100k ≤	
係数 Coefficient	4.7µF	0.35	0.42	0.60	0.80	1.00	係数 Coefficient	1~5.6µF	0.20	0.40	0.80	1.00	
	10~33µF	0.45	0.55	0.75	0.90	1.00		6.8~15µF	0.30	0.60	0.90	1.00	
	47~330µF	0.60	0.70	0.85	0.95	1.00		22~33µF	0.50	0.80	0.90	1.00	
	470~1500µF	0.65	0.75	0.90	0.98	1.00							
	2200~4700µF	0.75	0.80	0.95	1.00	1.00							

◆寸法図／DIMENSIONS

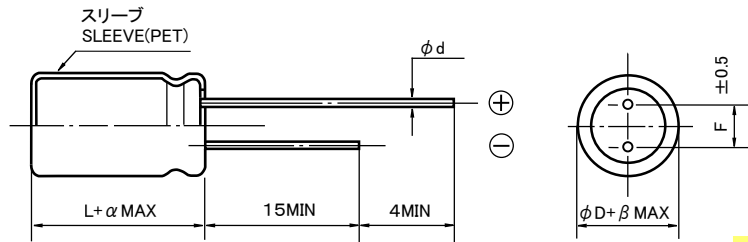

(mm)

ϕD	6.3	8	10	12.5	16	18
ϕd	0.5	0.6		0.8		
F	2.5	3.5	5.0		7.5	
α	2.0					
β	0.5			1.0		

◆標準品一覧表／STANDARD SIZE

定格電圧 Rated Voltage (Vdc)	静電容量 Capacitance (μF)	外形寸法 Size $\phi D \times L$ (mm)	定格リップル 電流 Rated Ripple Current	インピーダンス Impedance	
				20°C	100kHz
10	330	8x11.5	360	0.22	
	470	10x12.5	620	0.15	
	1000	10x20	960	0.073	
	2200	12.5x25	1430	0.040	
	3300	16x25	1900	0.038	
	4700	16x31.5	2300	0.034	
16	330	8x11.5	360	0.22	
	470	10x12.5	620	0.15	
	1000	10x20	960	0.073	
	2200	12.5x25	1430	0.040	
	3300	16x31.5	2300	0.034	
	4700	16x35.5	2550	0.031	
25	220	8x11.5	360	0.22	
	330	10x12.5	620	0.15	
	470	10x16	800	0.10	
	1000	12.5x20	1100	0.055	
	2200	16x31.5	2300	0.034	
	3300	16x35.5	2550	0.031	
35	100	8x11.5	360	0.22	
	220	10x12.5	620	0.15	
	330	10x16	800	0.10	
	470	10x20	960	0.073	
	1000	12.5x25	1430	0.040	
	2200	16x35.5	2550	0.031	
	3300	18x35.5	2800	0.028	
	4700	18x35.5	2800	0.028	
50	4.7	8x11.5	100	0.85	
	10	8x11.5	200	0.60	
	22	8x11.5	260	0.35	
	33	8x11.5	300	0.28	
	47	8x11.5	300	0.28	
	100	10x12.5	520	0.18	
	220	10x20	890	0.082	
	330	12.5x20	1000	0.065	
	470	12.5x25	1200	0.051	
	1000	16x31.5	2180	0.037	
63	33	8x11.5	250	0.40	
	47	10x12.5	400	0.27	
	100	10x16	450	0.20	
	220	12.5x20	820	0.10	
	330	12.5x25	1000	0.072	
	470	16x25	1500	0.069	
	1000	16x31.5	1850	0.056	
	1500	18x40	2350	0.043	

 =生産中止予定品
 Obsolete Products

 =新規設計非推奨品
 Not recommend to new design

Rated Ripple Current (mA r.m.s./130°C, 100kHz), Impedance (Ω MAX)

定格電圧 Rated Voltage (Vdc)	静電容量 Capacitance (μF)	外形寸法 Size $\phi D \times L$ (mm)	定格リップル 電流 Rated Ripple Current	インピーダンス Impedance
				20°C 100kHz
100	4.7	8x11.5	100	1.3
	10	8x11.5	200	1.0
	22	8x11.5	220	0.67
	33	10x12.5	260	0.45
	47	10x16	330	0.33
	100	12.5x20	670	0.17
	220	16x25	1100	0.13
	330	16x31.5	1300	0.10
	470	18x31.5	1600	0.092

定格電圧 Rated Voltage (Vdc)	静電容量 Capacitance (μF)	外形寸法 Size $\phi D \times L$ (mm)	定格リップル 電流 Rated Ripple Current
200	4.7	6.3x11	100
		8x11.5	120
	5.6	8x11.5	130
		8x16	180
	6.8	8x11.5	130
		8x16	180
	10	8x16	200
		8x20	240
	15	8x16	200
		8x20	240
22	8x20	300	
	10x16	240	
33	10x20	320	
400	1	6.3x11	60
		8x11.5	65
	1.5	8x11.5	75
		8x16	80
	1.8	8x11.5	75
		8x16	85
	2.2	8x11.5	75
		8x16	90
	2.7	8x16	110
		8x20	95
3.3	8x16	115	
	8x20	100	
4.7	8x20	120	
	10x16	120	
5.6	10x16	125	
	10x20	130	
6.8	10x20	145	
		150	150

RXA series

125°C 2000~3000時間, 小形化品
Load Life : 125°C 2000~3000hours, Miniaturized

AEC-Q200



◆規格表/SPECIFICATIONS

項目 Item	特性 Characteristics											
カテゴリ温度範囲 Category Temperature Range	-40 ~ +125°C											
定格電圧範囲 Rated Voltage Range	25 ~ 70Vdc											
静電容量許容差 Capacitance Tolerance	±20%(20°C, 120Hz)											
漏れ電流 Leakage Current (MAX)	I=0.01CV以下 (定格電圧印加2分後) I=0.01CV MAX (After 2 minute) I=漏れ電流 (μA) C=静電容量 (μF) V=定格電圧 (Vdc) Leakage Current Capacitance Rated Voltage											
損失角の正接 (tan δ) Dissipation Factor (MAX)	定格電圧 (Vdc) Rated Voltage	25	35	50	70	(20°C, 120Hz)						
	tan δ	0.14	0.12	0.10	0.10							
耐久性 Endurance	125°C中で右表の時間定格電圧 (定格リップル重畳) 印加後、下記項目を満足すること。 After applying rated voltage with rated ripple current for specified time at 125°C, the capacitors shall meet the following requirements.											
	静電容量変化率 Capacitance Change	初期値の±30%以内 Within ±30% of the initial value.				<table border="1"> <tr> <th>定格電圧 Rated Voltage</th> <th>時間(hrs) Time(hrs)</th> </tr> <tr> <td>25~50Vdc</td> <td>3000</td> </tr> <tr> <td>70Vdc</td> <td>2000</td> </tr> </table>	定格電圧 Rated Voltage	時間(hrs) Time(hrs)	25~50Vdc	3000	70Vdc	2000
	定格電圧 Rated Voltage	時間(hrs) Time(hrs)										
	25~50Vdc	3000										
70Vdc	2000											
損失角の正接 Dissipation Factor	規格値の 300% 以下 Not more than 300% of the specified value.											
漏れ電流 Leakage Current	規格値以下 Not more than the specified value.											
低温特性 Low Temperature Stability (インピーダンス比) Impedance Ratio (MAX)	定格電圧 (Vdc) Rated Voltage	25	35	50	70	(120Hz)						
	Z(-25°C)/Z(+20°C)	2	2	2	2							
	Z(-40°C)/Z(+20°C)	3	3	3	3							

◆呼称方法/PART NUMBER

RXA M D x L
 定格電圧 シリーズ名 静電容量 静電容量許容差 副記号 リード加工記号 ケースサイズ
 Rated Voltage Series Capacitance Capacitance Tolerance Option Lead Forming Case Size

◆リップル電流補正係数/
MULTIPLIER FOR RIPPLE CURRENT

周波数 (Hz) Frequency	120	1k	10k	100k ≤
240~680 μF	0.55	0.78	0.95	1.00
750~1800 μF	0.60	0.80	0.96	1.00
2000~5600 μF	0.70	0.86	0.98	1.00

◆副記号/OPTION

EFC : PETスリーブ PET Sleeve

◆寸法図／DIMENSIONS

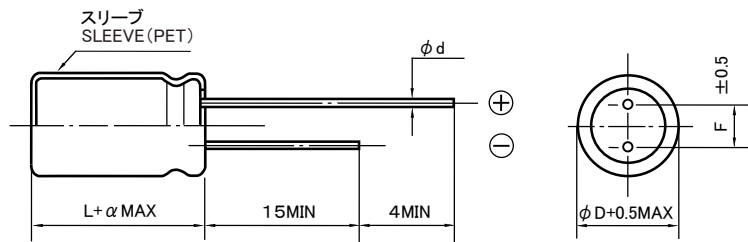

(mm)			
φD	12.5	16	18
φd	0.6	0.8	
F	5.0	7.5	
α	2.0		

◆標準品一覧表／STANDARD SIZE

定格電圧 Rated Voltage (Vdc)	静電容量 Capacitance (μF)	外形寸法 Size φD×L (mm)	定格リプル電流 Rated Ripple Current	等価直列抵抗 ESR	
				20°C	-40°C
25	1300	12.5×20	1510	0.068	0.71
	1600	12.5×20	1470	0.072	0.77
	1800	12.5×25	1900	0.050	0.52
	2000	16×20	1820	0.049	0.43
	2200	12.5×25	1850	0.053	0.57
	2200	12.5×30	2190	0.043	0.45
	2700	12.5×30	2130	0.046	0.49
	2700	16×20	1800	0.051	0.46
	2700	16×25	2250	0.038	0.33
	2700	18×20	1990	0.046	0.34
	3300	18×20	1970	0.047	0.37
	3600	16×25	2220	0.039	0.35
	3600	16×31.5	2720	0.029	0.25
	3900	18×25	2510	0.033	0.25
	4700	16×31.5	2670	0.030	0.27
	4700	18×25	2490	0.034	0.26
4700	18×31.5	2940	0.028	0.20	
5600	18×31.5	2910	0.028	0.22	
35	910	12.5×20	1510	0.068	0.71
	1100	12.5×20	1470	0.072	0.77
	1200	12.5×25	1900	0.050	0.52
	1500	12.5×25	1850	0.053	0.57
	1500	12.5×30	2190	0.043	0.45
	1500	16×20	1820	0.049	0.43
	1800	12.5×30	2130	0.046	0.49
	1800	16×20	1800	0.051	0.46
	1800	18×20	1990	0.046	0.34
	2000	16×25	2250	0.038	0.33
	2200	18×20	1970	0.047	0.37
	2400	16×25	2220	0.039	0.35
	2400	16×31.5	2720	0.029	0.25
	2700	18×25	2510	0.033	0.25
	3000	16×31.5	2670	0.030	0.27
	3300	18×25	2490	0.034	0.26
3300	18×31.5	2940	0.028	0.20	
3900	18×31.5	2910	0.028	0.22	

Rated Ripple Current (mA r.m.s./125°C, 100kHz) ESR (Ω MAX/ 100kHz)

定格電圧 Rated Voltage (Vdc)	静電容量 Capacitance (μF)	外形寸法 Size φD×L (mm)	定格リプル電流 Rated Ripple Current	等価直列抵抗 ESR	
				20°C	-40°C
50	510	12.5×20	1510	0.068	0.72
	620	12.5×20	1470	0.072	0.78
	680	12.5×25	1900	0.050	0.53
	820	12.5×25	1850	0.053	0.57
	820	12.5×30	2190	0.043	0.45
	820	16×20	1820	0.049	0.43
	1000	12.5×30	2130	0.046	0.49
	1000	16×20	1800	0.051	0.46
	1000	18×20	1990	0.046	0.35
	1100	16×25	2250	0.038	0.33
	1300	16×25	2220	0.039	0.35
	1300	18×20	1970	0.047	0.37
	1500	16×31.5	2720	0.029	0.25
	1500	18×25	2510	0.033	0.25
	1800	16×31.5	2670	0.030	0.27
	1800	18×25	2490	0.034	0.27
	1800	18×31.5	2940	0.028	0.20
	2200	18×31.5	2910	0.028	0.22
	70	240	12.5×20	1270	0.096
360		12.5×20	1230	0.100	0.78
360		12.5×25	1600	0.070	0.53
430		12.5×30	1850	0.061	0.46
430		16×20	1560	0.067	0.44
510		12.5×25	1550	0.075	0.57
510		18×20	1730	0.061	0.36
560		12.5×30	1790	0.065	0.49
560		16×20	1530	0.070	0.47
560		16×25	1930	0.051	0.33
750		16×25	1890	0.053	0.36
750		16×31.5	2330	0.040	0.26
750		18×20	1710	0.063	0.38
750		18×25	2190	0.044	0.25
1000		16×31.5	2280	0.042	0.27
1000		18×25	2160	0.045	0.27
1000		18×31.5	2560	0.036	0.21
1300		18×31.5	2530	0.037	0.22

RXF series

125°C 2000~5000時間品 高リップル、小形化品
125°C 2000~5000 hours, High Ripple Current, Miniaturized

AEC-Q200



◆規格表/SPECIFICATIONS

項目 Item	特性 Characteristics																					
カテゴリ温度範囲 Category Temperature Range	-55~+125°C																					
定格電圧範囲 Rated Voltage Range	25~80Vdc																					
静電容量許容差 Capacitance Tolerance	±20%(20°C, 120Hz)																					
漏れ電流 Leakage Current (MAX)	I=0.01CV以下(定格電圧印加2分後) I=0.01CV MAX. (After 2 minutes) I=漏れ電流(µA) C=静電容量(µF) V=定格電圧(Vdc) Leakage Current Capacitance Rated Voltage																					
損失角の正接(tan δ) Dissipation Factor (MAX)	<table border="1"> <tr> <td>定格電圧(Vdc) Rated Voltage</td> <td>25</td> <td>35</td> <td>50</td> <td>63</td> <td>80</td> <td>(20°C, 120Hz)</td> </tr> <tr> <td>tan δ</td> <td>0.14</td> <td>0.12</td> <td>0.10</td> <td>0.09</td> <td>0.08</td> <td></td> </tr> </table> <p>1000µFを越えるものは1000µF増す毎に上表の値に0.02を加えた値とする。 When capacitance is over 1000µF, tan δ shall be added 0.02 to the listed value with increase of every 1000µF.</p>		定格電圧(Vdc) Rated Voltage	25	35	50	63	80	(20°C, 120Hz)	tan δ	0.14	0.12	0.10	0.09	0.08							
定格電圧(Vdc) Rated Voltage	25	35	50	63	80	(20°C, 120Hz)																
tan δ	0.14	0.12	0.10	0.09	0.08																	
耐久性 Endurance	<p>125°C中で右表の時間定格電圧(定格リップル重畳)印加後、下記項目を満足すること。 After applying rated voltage with rated ripple current for specified time at 125°C, the capacitors shall meet the following requirements.</p> <table border="1"> <tr> <td>静電容量変化率 Capacitance Change</td> <td>初期値の±30%以内 Within ±30% of the initial value.</td> <td>ケースサイズ Case Size</td> <td>時間(hrs) Time(hrs)</td> </tr> <tr> <td>損失角の正接 Dissipation Factor</td> <td>規格値の300%以下 Not more than 300% of the specified value.</td> <td>10x16, 10x20</td> <td>2000</td> </tr> <tr> <td>漏れ電流 Leakage Current</td> <td>規格値以下 Not more than the specified value.</td> <td>10x25</td> <td>3000</td> </tr> <tr> <td></td> <td></td> <td>φD≥12.5(63~80Vdc)</td> <td>5000</td> </tr> <tr> <td></td> <td></td> <td>φD≥12.5(25~50Vdc)</td> <td></td> </tr> </table>		静電容量変化率 Capacitance Change	初期値の±30%以内 Within ±30% of the initial value.	ケースサイズ Case Size	時間(hrs) Time(hrs)	損失角の正接 Dissipation Factor	規格値の300%以下 Not more than 300% of the specified value.	10x16, 10x20	2000	漏れ電流 Leakage Current	規格値以下 Not more than the specified value.	10x25	3000			φD≥12.5(63~80Vdc)	5000			φD≥12.5(25~50Vdc)	
静電容量変化率 Capacitance Change	初期値の±30%以内 Within ±30% of the initial value.	ケースサイズ Case Size	時間(hrs) Time(hrs)																			
損失角の正接 Dissipation Factor	規格値の300%以下 Not more than 300% of the specified value.	10x16, 10x20	2000																			
漏れ電流 Leakage Current	規格値以下 Not more than the specified value.	10x25	3000																			
		φD≥12.5(63~80Vdc)	5000																			
		φD≥12.5(25~50Vdc)																				
低温特性 Low Temperature Stability (インピーダンス比) Impedance Ratio (MAX)	<table border="1"> <tr> <td>定格電圧(Vdc) Rated Voltage</td> <td>25</td> <td>35</td> <td>50</td> <td>63</td> <td>80</td> <td>(120Hz)</td> </tr> <tr> <td>Z(-55°C)/Z(+20°C)</td> <td>3</td> <td>3</td> <td>3</td> <td>3</td> <td>3</td> <td></td> </tr> </table>		定格電圧(Vdc) Rated Voltage	25	35	50	63	80	(120Hz)	Z(-55°C)/Z(+20°C)	3	3	3	3	3							
定格電圧(Vdc) Rated Voltage	25	35	50	63	80	(120Hz)																
Z(-55°C)/Z(+20°C)	3	3	3	3	3																	

◆呼称方法/PART NUMBER

RXF M D x L
 定格電圧 シリーズ名 静電容量 静電容量許容差 副記号 リード加工記号 ケースサイズ
 Rated Voltage Series Capacitance Capacitance Tolerance Option Lead Forming Case Size

◆リップル電流補正係数/
MULTIPLIER FOR RIPPLE CURRENT

周波数(Hz) Frequency	120	1k	10k	100k≤
180~270µF	0.50	0.73	0.92	1.00
330~680µF	0.55	0.77	0.94	1.00
750~1800µF	0.60	0.80	0.96	1.00
2000~7500µF	0.70	0.85	0.98	1.00

◆副記号/OPTION

EFC : PETスリーブ PET Sleeve

◆寸法図／DIMENSIONS

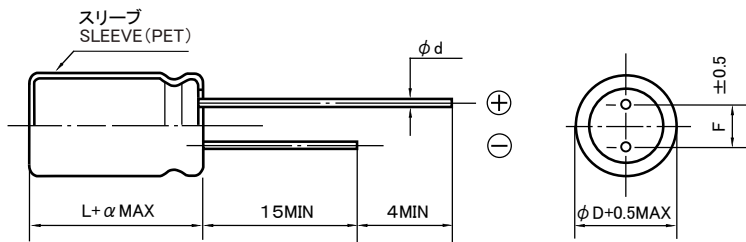

(mm)

φD	10	12.5	16	18
φd	0.6		0.8	
F	5.0		7.5	
α	2.0			

◆標準品一覧表／STANDARD SIZE

Rated Ripple Current (mA r.m.s./125°C,100kHz)

定格電圧 Rated Voltage (Vdc)	静電容量 Capacitance (μF)	外形寸法 Size φD×L(mm)	定格リプル電流 RatedRipple Current	等価直列抵抗 ESR (Ω MAX)	
				20°C, 100kHz	-40°C, 100kHz
25	750	10×16	1300	0.078	0.520
	1200	10×20	1540	0.058	0.390
	1500	10×25	1880	0.042	0.300
	1800	12.5×20	1590	0.038	0.220
	2700	12.5×25	2280	0.030	0.160
	3000	16×20	1890	0.029	0.130
	3300	12.5×30	2760	0.025	0.130
	4300	16×25	3030	0.022	0.092
	4300	18×20	1930	0.028	0.110
	5100	16×30	3330	0.018	0.071
	5600	18×25	3200	0.020	0.081
	7500	18×30	3480	0.016	0.066
35	510	10×16	1300	0.078	0.520
	680	10×20	1540	0.058	0.390
	820	10×25	1880	0.042	0.300
	1100	12.5×20	1590	0.038	0.220
	1500	12.5×25	2280	0.030	0.160
	2000	12.5×30	2760	0.025	0.130
	2000	16×20	1890	0.029	0.130
	2400	16×25	3030	0.022	0.092
	2400	18×20	1930	0.028	0.110
	3300	16×30	3330	0.018	0.071
	3300	18×25	3200	0.020	0.081
	4300	18×30	3480	0.016	0.066
50	240	10×16	1080	0.120	0.940
	330	10×20	1290	0.088	0.690
	430	10×25	1740	0.062	0.480
	510	12.5×20	1410	0.060	0.410
	750	12.5×25	2030	0.044	0.300
	910	16×20	1740	0.042	0.210
	1000	12.5×30	2510	0.036	0.250
	1200	18×20	1830	0.040	0.200
	1300	16×25	2690	0.030	0.160
	1600	16×30	3150	0.025	0.130
	1800	18×25	2900	0.029	0.150
	2200	18×30	3330	0.024	0.120

定格電圧 Rated Voltage (Vdc)	静電容量 Capacitance (μF)	外形寸法 Size φD×L(mm)	定格リプル電流 RatedRipple Current	等価直列抵抗 ESR (Ω MAX)	
				20°C, 100kHz	-40°C, 100kHz
63	390	12.5×20	1310	0.094	0.480
	510	12.5×25	1880	0.069	0.360
	620	16×20	1630	0.062	0.240
	680	12.5×30	2410	0.052	0.290
	820	18×20	1750	0.055	0.220
	910	16×25	2300	0.047	0.180
	1100	16×30	2940	0.037	0.140
	1200	18×25	2440	0.042	0.160
	1500	18×30	3100	0.034	0.130
	180	10×20	1250	0.134	1.700
	240	10×25	1530	0.101	1.200
	270	12.5×20	1310	0.103	0.940
80	330	12.5×25	1880	0.075	0.700
	470	12.5×30	2410	0.060	0.520
	470	16×20	1630	0.064	0.530
	680	16×25	2300	0.046	0.390
	820	16×30	2940	0.037	0.330
	620	18×20	1790	0.057	0.390
	820	18×25	2440	0.041	0.320
	1000	18×30	3100	0.034	0.260

RXG series

150°C 1500時間品
Load Life : 150°C 1500hours

・車載機器等の高温用途に最適
Solution for high temperature application such as automobile electronics.

AEC-Q200

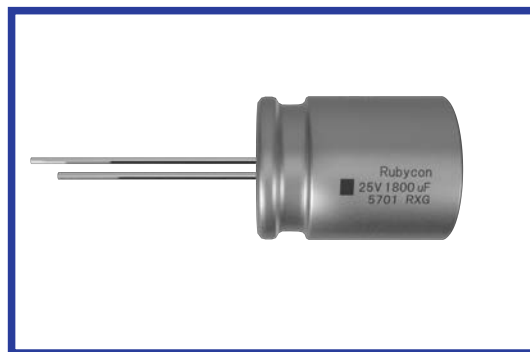

◆規格表/SPECIFICATIONS

項目 Item	特性 Characteristics													
カテゴリ温度範囲 Category Temperature Range	-40~+150°C													
定格電圧範囲 Rated Voltage Range	25~50Vdc													
静電容量許容差 Capacitance Tolerance	±20%(20°C, 120Hz)													
漏れ電流 Leakage Current (MAX)	I=0.01CV又は3µAのいずれか大なる値以下(定格電圧印加2分後) I=0.01CV or 3µA whichever is greater. (After 2 minutes) I=漏れ電流(µA) C=静電容量(µF) V=定格電圧(Vdc) Leakage Current Capacitance Rated Voltage													
損失角の正接(tan δ) Dissipation Factor (MAX)	<table border="1"> <tr> <td>定格電圧(Vdc) Rated Voltage</td> <td>25</td> <td>35</td> <td>50</td> <td rowspan="2">(20°C, 120Hz)</td> </tr> <tr> <td>tan δ</td> <td>0.14</td> <td>0.12</td> <td>0.10</td> </tr> </table> <p>1000µFを超えるものは1000µF増す毎に上記の表に0.02を加えた値とする。</p>	定格電圧(Vdc) Rated Voltage	25	35	50	(20°C, 120Hz)	tan δ	0.14	0.12	0.10				
定格電圧(Vdc) Rated Voltage	25	35	50	(20°C, 120Hz)										
tan δ	0.14	0.12	0.10											
耐久性 Endurance	<p>150°C中で1500時間定格電圧(定格リップル重畳)印加後、下記規格を満足すること。 After applying rated voltage with rated ripple current for 1500 hours at 150°C, the capacitors shall meet the following requirements.</p> <table border="1"> <tr> <td>静電容量変化率 Capacitance Change</td> <td>初期値の ±30% 以内 Within ±30% of the initial value.</td> </tr> <tr> <td>損失角の正接 Dissipation Factor</td> <td>規格値の 300% 以下 Not more than 300% of the specified value.</td> </tr> <tr> <td>漏れ電流 Leakage Current</td> <td>規格値以下 Not more than the specified value.</td> </tr> </table>	静電容量変化率 Capacitance Change	初期値の ±30% 以内 Within ±30% of the initial value.	損失角の正接 Dissipation Factor	規格値の 300% 以下 Not more than 300% of the specified value.	漏れ電流 Leakage Current	規格値以下 Not more than the specified value.							
静電容量変化率 Capacitance Change	初期値の ±30% 以内 Within ±30% of the initial value.													
損失角の正接 Dissipation Factor	規格値の 300% 以下 Not more than 300% of the specified value.													
漏れ電流 Leakage Current	規格値以下 Not more than the specified value.													
低温特性 Low Temperature Stability (インピーダンス比) Impedance Ratio (MAX)	<table border="1"> <tr> <td>定格電圧(Vdc) Rated Voltage</td> <td>25</td> <td>35</td> <td>50</td> <td rowspan="3">(120Hz)</td> </tr> <tr> <td>Z(-25°C)/Z(+20°C)</td> <td>2</td> <td>2</td> <td>2</td> </tr> <tr> <td>Z(-40°C)/Z(+20°C)</td> <td>4</td> <td>4</td> <td>4</td> </tr> </table>	定格電圧(Vdc) Rated Voltage	25	35	50	(120Hz)	Z(-25°C)/Z(+20°C)	2	2	2	Z(-40°C)/Z(+20°C)	4	4	4
定格電圧(Vdc) Rated Voltage	25	35	50	(120Hz)										
Z(-25°C)/Z(+20°C)	2	2	2											
Z(-40°C)/Z(+20°C)	4	4	4											

◆呼称方法/PART NUMBER

RXG M D x L
 定格電圧 シリーズ名 静電容量 静電容量許容差 副記号 リード加工記号 ケースサイズ
 Rated Voltage Series Capacitance Capacitance Tolerance Option Lead Forming Case Size

◆リップル電流補正係数/
MULTIPLIER FOR RIPPLE CURRENT

周波数 (Hz) Frequency	120	1k	10k	100k ≤	
係数 Coefficient	390~560 µF	0.50	0.74	0.94	1.00
	680~1800 µF	0.60	0.74	0.94	1.00
	2000~3600 µF	0.64	0.75	0.95	1.00

◆副記号/OPTION

標準品はブランクとなります。
Standard item is blank

◆寸法図／DIMENSIONS

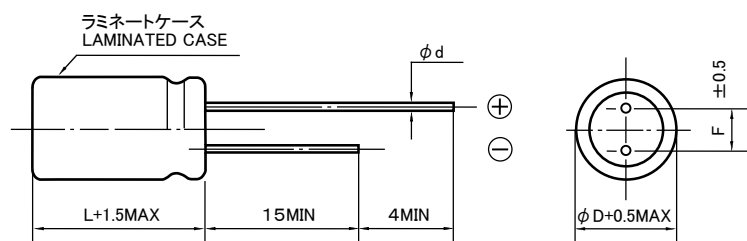

(mm)

φD	12.5	16	18
φd	0.6	0.8	
F	5.0		7.5

◆標準品一覧表／STANDARD SIZE

Rated Ripple Current (mA r.m.s./150°C,100kHz)

定格電圧 Rated Voltage (Vdc)	静電容量 Capacitance (μF)	外形寸法 Size φD×L (mm)	定格リプル電流 Rated Ripple Current	等価直列抵抗 ESR(Ω MAX)	
				20°C,100kHz	-40°C,100kHz
25	1100	12.5×20	1150	0.070	1.0
	1600	12.5×25	1400	0.050	0.75
	1800	16×20	1520	0.045	0.60
	2400	18×20	1610	0.040	0.50
	2700	16×25	1750	0.035	0.43
	3600	18×25	1850	0.030	0.35
35	560	12.5×20	1150	0.070	1.0
	820	12.5×25	1400	0.050	0.75
	1000	16×20	1520	0.045	0.60
	1300	18×20	1610	0.040	0.50
	1400	16×25	1750	0.035	0.43
	2000	18×25	1850	0.030	0.35
50	390	12.5×20	860	0.12	2.5
	560	12.5×25	1100	0.085	2.0
	680	16×20	1100	0.075	1.5
	910	18×20	1170	0.065	1.2
	1000	16×25	1400	0.055	1.1
	1300	18×25	1500	0.045	1.0

RXL series

125°C 3000~8000時間品 高リップル、小形化品
125°C 3000~8000 hours, High Ripple Current, Miniaturized

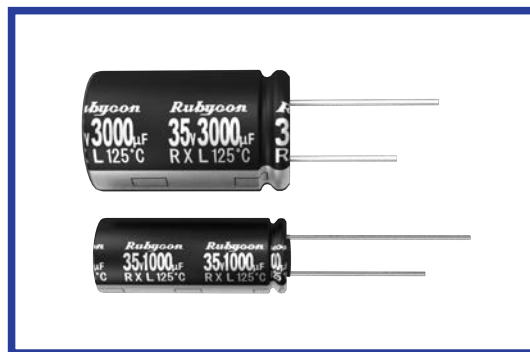

◆規格表/SPECIFICATIONS

項目 Item	特性 Characteristics			
カテゴリ温度範囲 Category Temperature Range	-55~+125°C			
定格電圧範囲 Rated Voltage Range	16~35Vdc			
静電容量許容差 Capacitance Tolerance	±20%(20°C, 120Hz)			
漏れ電流 Leakage Current (MAX)	I=0.01CV又は3µAのいずれか大なる値以下(定格電圧印加2分後) I=0.01CV or 3µA whichever is greater. (After 2 minutes) I=漏れ電流(µA) C=静電容量(µF) V=定格電圧(Vdc) Leakage Current Capacitance Rated Voltage			
損失角の正接(tan δ) Dissipation Factor (MAX)	定格電圧(Vdc) Rated Voltage	16	25	35
	tan δ	0.16	0.14	0.12
1000µFを越えるものは1000µF増す毎に上表の値に0.02を加えた値とする。 When capacitance is over 1000µF, tan δ shall be added 0.02 to the listed value with increase of every 1000µF.				
耐久性 Endurance	125°C中で右表の時間定格電圧(定格リップル重畳)印加後、下記項目を満足すること。 After applying rated voltage with rated ripple current for specified time at 125°C, the capacitors shall meet the following requirements.			
	静電容量変化率 Capacitance Change	初期値の±30%以内 Within ±30% of the initial value.		ケースサイズ Case Size
	損失角の正接 Dissipation Factor	規格値の300%以下 Not more than 300% of the specified value.		時間(hrs) Time(hrs)
	漏れ電流 Leakage Current	規格値以下 Not more than the specified value.		10x16 3000 10x20 4000 10x25 5000 φD ≥ 12.5 L ≤ 20 6000 L ≥ 25 8000
低温特性 Low Temperature Stability (インピーダンス比) Impedance Ratio (MAX)	定格電圧(Vdc) Rated Voltage	16	25	35
Z(-55°C)/Z(+20°C)				
3 3 3 (120Hz)				

◆呼称方法/PART NUMBER

RXL M D x L
 定格電圧 シリーズ名 静電容量 静電容量許容差 副記号 リード加工記号 ケースサイズ
 Rated Voltage Series Capacitance Capacitance Tolerance Option Lead Forming Case Size

◆リップル電流補正係数/
MULTIPLIER FOR RIPPLE CURRENT

周波数(Hz) Frequency	120	1k	10k	100k ≤
510µF	0.55	0.77	0.94	1.00
750~1800µF	0.60	0.80	0.96	1.00
2000~7500µF	0.70	0.85	0.98	1.00

◆副記号/OPTION

EFC : PETスリーブ PET Sleeve

◆寸法図／DIMENSIONS

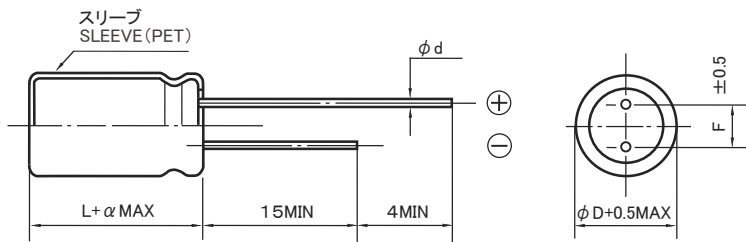

(mm)

ϕD	10	12.5	16	18
ϕd	0.6		0.8	
F	5.0		7.5	
α	2.0			

◆標準品一覧表／STANDARD SIZE

定格電圧 Rated Voltage (Vdc)	静電容量 Capacitance (μF)	外形寸法 Size $\phi D \times L$ (mm)	定格リップル電流 Rated Ripple Current	等価直列抵抗 ESR (Ω MAX)	
				20°C, 100kHz	-40°C, 100kHz
16	1200	10×16	1180	0.084	0.760
	1800	10×20	1470	0.062	0.550
	2400	10×25	1810	0.047	0.410
	2700	12.5×20	1590	0.042	0.290
	3900	12.5×25	2280	0.030	0.210
	4700	12.5×30	2760	0.025	0.170
25	820	10×16	1180	0.084	0.760
	1200	10×20	1470	0.062	0.550
	1600	10×25	1810	0.047	0.410
	1800	12.5×20	1590	0.042	0.290
	2700	12.5×25	2280	0.030	0.210
	3300	12.5×30	2760	0.025	0.170
	3300	16×20	1890	0.034	0.140
	4300	18×20	1930	0.033	0.120
	4700	16×25	3030	0.025	0.100
	5600	16×30	3330	0.020	0.080
	6200	18×25	3200	0.024	0.086
	7500	18×30	3480	0.020	0.070

Rated Ripple Current (mA r.m.s./125°C, 100kHz)

定格電圧 Rated Voltage (Vdc)	静電容量 Capacitance (μF)	外形寸法 Size $\phi D \times L$ (mm)	定格リップル電流 Rated Ripple Current	等価直列抵抗 ESR (Ω MAX)	
				20°C, 100kHz	-40°C, 100kHz
35	510	10×16	1180	0.084	0.760
	750	10×20	1470	0.062	0.550
	1000	10×25	1810	0.047	0.410
	1100	12.5×20	1590	0.042	0.290
	1500	12.5×25	2280	0.030	0.210
	2000	12.5×30	2760	0.025	0.170
	2000	16×20	1890	0.034	0.140
	2700	18×20	1930	0.033	0.120
	3000	16×25	3030	0.025	0.100
	3600	16×30	3330	0.020	0.080
	3900	18×25	3200	0.024	0.086
	4700	18×30	3480	0.020	0.070

YXJ series

105°C 4000~10000時間品 小形化 長寿命品
Load Life : 105°C 4000~10000 hours, Miniaturized, Long Life



◆規格表/SPECIFICATIONS

項目 Item	特性 Characteristics															
カテゴリ温度範囲 Category Temperature Range	-40~+105°C															
定格電圧範囲 Rated Voltage Range	6.3~100Vdc															
静電容量許容差 Capacitance Tolerance	±20%(20°C, 120Hz)															
漏れ電流 Leakage Current (MAX)	I=0.01CV又は3μAのいずれか大なる値以下(定格電圧印加2分後) I=0.01CV or 3μA whichever is greater. (After 2 minutes) I=漏れ電流(μA) C=静電容量(μF) V=定格電圧(Vdc) Leakage Current Capacitance Rated Voltage															
損失角の正接(tan δ) Dissipation Factor (MAX)	定格電圧(Vdc) Rated Voltage	6.3 10 16 25 35 50 63 100 (20°C, 120Hz)														
	tan δ	0.22 0.19 0.16 0.14 0.12 0.10 0.09 0.08														
1000μFを越えるものは1000μF増す毎に上表の値に0.02を加えた値とする。 When capacitance is over 1000μF, tan δ shall be added 0.02 to the listed value with increase of every 1000μF.																
耐久性 Endurance	105°C中で右表の時間定格電圧(リップル重畳)印加後、下記項目を満足すること。 After applying rated voltage with rated ripple current for specified time at 105°C, the capacitors shall meet the following requirements.															
	静電容量変化率 Capacitance Change	初期値の±25%以内(6.3Vdc: ±30%) Within ±25% of the initial value(6.3Vdc: ±30%)														
	損失角の正接 Dissipation Factor	規格値の200%以下 Not more than 200% of the specified value.														
	漏れ電流 Leakage Current	規格値以下 Not more than the specified value.														
		<table border="1"> <thead> <tr> <th rowspan="2">ケースサイズ Case Size</th> <th colspan="2">時間(hrs) Time(hrs)</th> </tr> <tr> <th>6.3~10Vdc</th> <th>16~100Vdc</th> </tr> </thead> <tbody> <tr> <td>φD=5</td> <td>4000</td> <td>5000</td> </tr> <tr> <td>φD=6.3,8</td> <td>6000</td> <td>7000</td> </tr> <tr> <td>φD≥10</td> <td>8000</td> <td>10000</td> </tr> </tbody> </table>	ケースサイズ Case Size	時間(hrs) Time(hrs)		6.3~10Vdc	16~100Vdc	φD=5	4000	5000	φD=6.3,8	6000	7000	φD≥10	8000	10000
ケースサイズ Case Size	時間(hrs) Time(hrs)															
	6.3~10Vdc	16~100Vdc														
φD=5	4000	5000														
φD=6.3,8	6000	7000														
φD≥10	8000	10000														
低温特性 Low Temperature Stability (インピーダンス比) Impedance Ratio (MAX)	定格電圧(Vdc) Rated Voltage	6.3 10 16 25 35 50 63 100 (120Hz)														
	Z(-25°C)/Z(+20°C)	4 3 2 2 2 2 2 2														
	Z(-40°C)/Z(+20°C)	8 6 4 3 3 3 3 3														

◆呼称方法/PART NUMBER

YXJ M D x L
 定格電圧 シリーズ名 静電容量 静電容量許容差 副記号 リード加工記号 ケースサイズ
 Rated Voltage Series Capacitance Capacitance Tolerance Option Lead Forming Case Size

◆副記号/OPTION

標準品はブランクとなります。Standard item is blank.

◆リップル電流補正係数/MULTIPLIER FOR RIPPLE CURRENT

		6.3~50Vdc			
Frequency (Hz)		120	1k	10k	100k≤
係数 Coefficient	1μF	0.35	0.60	0.80	1.00
	2.2~10μF	0.42	0.60	0.80	1.00
	22~47μF	0.55	0.75	0.90	1.00
	100~330μF	0.70	0.85	0.95	1.00
	470~1000μF	0.75	0.90	0.98	1.00
	2200~15000μF	0.80	0.95	1.00	1.00

		63~100Vdc			
Frequency (Hz)		120	1k	10k	100k≤
Coefficient	63~100Vdc	0.42	0.60	0.80	1.00

◆寸法図／DIMENSIONS

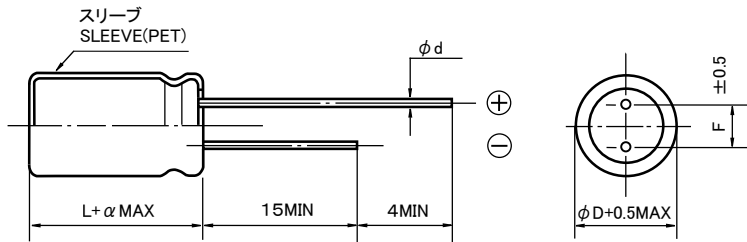

φD	5	6.3	8	10	12.5	16
φd	0.5		0.6			0.8
F	2.0	2.5	3.5	5.0		7.5
α	L ≤ 16 : α = 1.5 L ≥ 20 : α = 2.0					

(mm)

◆標準品一覧表／STANDARD SIZE

Rated Ripple Current (mA r.m.s./105°C, 100kHz)

定格電圧 Rated Voltage (Vdc)	静電容量 Capacitance (μF)	外形寸法 Size φD × L (mm)	定格リプル 電流 Rated Ripple Current	インピーダンス(Ω MAX) Impedance	
				20°C, 100kHz	-10°C, 100kHz
6.3	100	5×11	150	0.90	3.6
	220	5×11	250	0.40	1.2
	330	6.3×11	340	0.22	0.87
	470	6.3×11	400	0.22	0.87
	1000	8×11.5	640	0.13	0.52
	2200	10×16	1300	0.062	0.25
	3300	10×20	1400	0.046	0.18
	4700	12.5×25	2230	0.032	0.11
	6800	12.5×25	2230	0.032	0.11
	10000	16×25	2930	0.021	0.060
15000	16×35.5	3610	0.015	0.044	
10	100	5×11	150	0.90	3.6
	220	5×11	250	0.40	1.2
	330	6.3×11	400	0.22	0.87
	470	6.3×11	400	0.22	0.87
	1000	10×12.5	865	0.08	0.32
	2200	10×20	1400	0.046	0.18
	3300	12.5×20	1900	0.041	0.14
	4700	12.5×25	2230	0.032	0.11
	6800	16×25	2930	0.021	0.060
	10000	16×31.5	3450	0.019	0.056
16	47	5×11	250	0.40	1.2
	100	5×11	250	0.40	1.2
	220	6.3×11	400	0.22	0.87
	330	6.3×11	400	0.22	0.87
	470	8×11.5	640	0.13	0.52
	1000	10×16	1210	0.062	0.25
	2200	12.5×20	1900	0.041	0.14
	3300	12.5×25	2230	0.032	0.11
4700	16×25	2930	0.021	0.060	
6800	16×31.5	3450	0.019	0.056	
25	33	5×11	250	0.40	1.2
	47	5×11	250	0.40	1.2
	100	5×11	250	0.40	1.2
	220	6.3×11	400	0.22	0.87
	330	8×11.5	640	0.13	0.52
	470	10×12.5	865	0.08	0.32
	1000	10×20	1400	0.046	0.18
	2200	12.5×25	2230	0.032	0.11
	3300	16×25	2930	0.021	0.060
4700	16×31.5	3450	0.019	0.056	

定格電圧 Rated Voltage (Vdc)	静電容量 Capacitance (μF)	外形寸法 Size φD × L (mm)	定格リプル 電流 Rated Ripple Current	インピーダンス(Ω MAX) Impedance	
				20°C, 100kHz	-10°C, 100kHz
35	33	5×11	250	0.40	1.2
	47	5×11	250	0.40	1.2
	100	6.3×11	400	0.22	0.87
	220	8×11.5	640	0.13	0.52
	330	10×12.5	865	0.08	0.32
	470	10×16	1210	0.062	0.25
	1000	12.5×20	1900	0.041	0.14
	2200	16×25	2930	0.021	0.060
	3300	16×31.5	3450	0.019	0.056
	50	1	5×11	30	4.0
2.2		5×11	43	2.5	6.0
3.3		5×11	53	2.2	5.6
4.7		5×11	88	1.9	5.0
10		5×11	100	1.5	4.0
22		5×11	180	0.7	2.8
33		5×11	250	0.7	2.8
47		6.3×11	295	0.3	1.2
100		8×11.5	555	0.17	0.68
220		10×16	1050	0.084	0.34
330		10×20	1220	0.06	0.24
470		12.5×20	1660	0.045	0.15
1000		16×25	2730	0.032	0.096
2200		16×35.5	3150	0.019	0.057
63	10	5×11	173	0.88	3.5
	22	5×11	173	0.88	3.5
	33	6.3×11	278	0.35	1.4
	47	6.3×11	278	0.35	1.4
	100	10×12.5	725	0.15	0.60
	220	10×20	1200	0.078	0.31
	330	12.5×20	1570	0.06	0.19
	470	12.5×25	1990	0.043	0.14
	1000	16×25	2730	0.032	0.096
	100	1	5×11	20	4.5
2.2		5×11	30	3.0	13.0
3.3		5×11	40	2.7	11.0
4.7		5×11	65	2.5	10.0
10		6.3×11	267	0.57	2.3
22		6.3×11	267	0.57	2.3
33		8×11.5	462	0.36	1.4
47		8×16	585	0.25	1.0
100		10×20	1040	0.12	0.52
220		12.5×25	1620	0.06	0.23
330		16×25	2210	0.044	0.16

＝生産中止予定品
OBSELETE PRODUCTS

＝新規設計非推奨品
Not recommend to new design

YXM series

105°C 10000時間品 小形化品, -40°C対応
Load Life : 105°C 10000 hours, Miniaturized, -40°C~+105°C

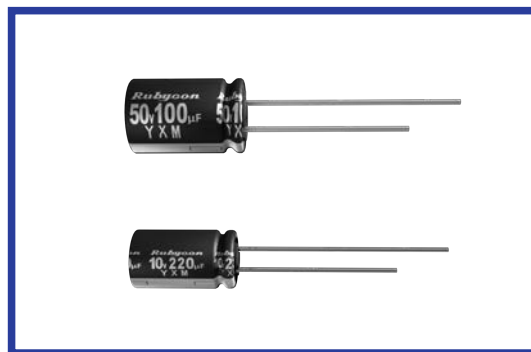

◆規格表/SPECIFICATIONS

項目 Item	特性 Characteristics																		
カテゴリ温度範囲 Category Temperature Range	-40~+105°C																		
定格電圧範囲 Rated Voltage Range	10~100Vdc																		
静電容量許容差 Capacitance Tolerance	±20%(20°C, 120Hz)																		
漏れ電流 Leakage Current (MAX)	I=0.01CV又は3µAのいずれか大なる値以下(定格電圧印加2分後) I=0.01CV or 3µA whichever is greater. (After 2 minutes) I=漏れ電流(µA) C=静電容量(µF) V=定格電圧(Vdc) Leakage Current Capacitance Rated Voltage																		
損失角の正接(tan δ) Dissipation Factor (MAX)	<table border="1"> <tr> <td>定格電圧(Vdc) Rated Voltage</td> <td>10</td> <td>16</td> <td>25</td> <td>35</td> <td>50</td> <td>63</td> <td>100</td> <td>(20°C, 120Hz)</td> </tr> <tr> <td>tan δ</td> <td>0.45</td> <td>0.35</td> <td>0.30</td> <td>0.22</td> <td>0.19</td> <td>0.17</td> <td>0.15</td> <td></td> </tr> </table>	定格電圧(Vdc) Rated Voltage	10	16	25	35	50	63	100	(20°C, 120Hz)	tan δ	0.45	0.35	0.30	0.22	0.19	0.17	0.15	
定格電圧(Vdc) Rated Voltage	10	16	25	35	50	63	100	(20°C, 120Hz)											
tan δ	0.45	0.35	0.30	0.22	0.19	0.17	0.15												
耐久性 Endurance	105°C中で10000時間定格電圧(リップル重畳)印加後、下記項目を満足すること。 After applying rated voltage with rated ripple current for 10000hours at 105°C, the capacitors shall meet the following requirements. <table border="1"> <tr> <td>静電容量変化率 Capacitance Change</td> <td>初期値の ±25% 以内 Within ±25% of the initial value.</td> </tr> <tr> <td>損失角の正接 Dissipation Factor</td> <td>規格値の 300% 以下 Not more than 300% of the specified value.</td> </tr> <tr> <td>漏れ電流 Leakage Current</td> <td>規格値以下 Not more than the specified value.</td> </tr> </table>	静電容量変化率 Capacitance Change	初期値の ±25% 以内 Within ±25% of the initial value.	損失角の正接 Dissipation Factor	規格値の 300% 以下 Not more than 300% of the specified value.	漏れ電流 Leakage Current	規格値以下 Not more than the specified value.												
静電容量変化率 Capacitance Change	初期値の ±25% 以内 Within ±25% of the initial value.																		
損失角の正接 Dissipation Factor	規格値の 300% 以下 Not more than 300% of the specified value.																		
漏れ電流 Leakage Current	規格値以下 Not more than the specified value.																		
低温特性 Low Temperature Stability (インピーダンス比) Impedance Ratio (MAX)	<table border="1"> <tr> <td>定格電圧(Vdc) Rated Voltage</td> <td>10</td> <td>16</td> <td>25</td> <td>35</td> <td>50</td> <td>63</td> <td>100</td> <td>(120Hz)</td> </tr> <tr> <td>Z(-25°C)/Z(+20°C)</td> <td>8</td> <td>6</td> <td>4</td> <td>4</td> <td>3</td> <td>3</td> <td>3</td> <td></td> </tr> </table>	定格電圧(Vdc) Rated Voltage	10	16	25	35	50	63	100	(120Hz)	Z(-25°C)/Z(+20°C)	8	6	4	4	3	3	3	
定格電圧(Vdc) Rated Voltage	10	16	25	35	50	63	100	(120Hz)											
Z(-25°C)/Z(+20°C)	8	6	4	4	3	3	3												

◆呼称方法/PART NUMBER

□□□ YXM □□□□□ M □□□ □□ D x L
 定格電圧 シリーズ名 静電容量 静電容量許容差 副記号 リード加工記号 ケースサイズ
 Rated Voltage Series Capacitance Capacitance Tolerance Option Lead Forming Case Size

◆リップル電流補正係数/
MULTIPLIER FOR RIPPLE CURRENT

周波数 (Hz) Frequency		120	1k	10k	100k ≤
係数 Coefficient	1~10 µF	0.42	0.60	0.80	1.00
	22~33 µF	0.55	0.75	0.90	1.00
	47~330 µF	0.70	0.85	0.95	1.00

◆副記号/OPTION

EFR : PETスリーブ PET Sleeve

◆寸法図／DIMENSIONS

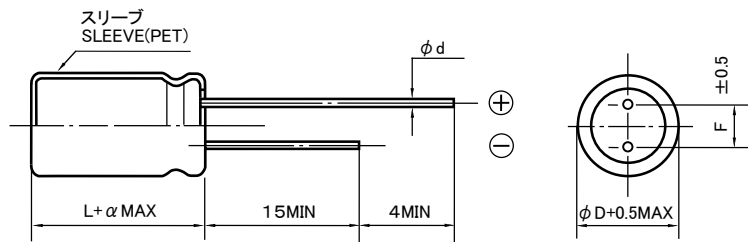

(mm)

ϕD	5	6.3	8
ϕd	0.5		0.6
F	2.0	2.5	3.5
α	1.5		

◆標準品一覧表／STANDARD SIZE

Rated Ripple Current (mA r.m.s./105°C, 100kHz)

定格電圧 Rated Voltage (Vdc)	静電容量 Capacitance (μF)	外形寸法 Size $\phi D \times L$ (mm)	定格リプル 電流 RatedRipple Current
10	100	5×11	130
	220	6.3×11	210
	330	8×11.5	330
16	47	5×11	130
	100	6.3×11	210
	220	8×11.5	330
25	33	5×11	130
	47	5×11	130
	100	6.3×11	210
35	33	5×11	130
	47	6.3×11	210
	100	8×11.5	330

定格電圧 Rated Voltage (Vdc)	静電容量 Capacitance (μF)	外形寸法 Size $\phi D \times L$ (mm)	定格リプル 電流 RatedRipple Current
50	1	5×11	25
	2.2	5×11	35
	3.3	5×11	70
	4.7	5×11	80
	10	5×11	90
	22	5×11	135
	33	6.3×11	190
	47	6.3×11	190
	100	8×11.5	270
63	10	5×11	80
	22	6.3×11	170
	33	6.3×11	170
	47	8×11.5	240
100	1	5×11	40
	2.2	5×11	50
	3.3	5×11	60
	4.7	5×11	70
	10	6.3×11	150
	22	8×11.5	230

YXS series

105°C 3000~6000時間品 小形化 低インピーダンス品
Load Life : 105°C 3000~6000 hours, Miniaturized, Low Impedance

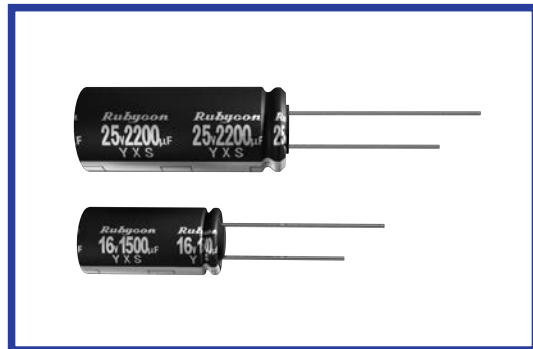

◆規格表/SPECIFICATIONS

項目 Item	特性 Characteristics																								
カテゴリ温度範囲 Category Temperature Range	-40~+105°C																								
定格電圧範囲 Rated Voltage Range	6.3~50Vdc																								
静電容量許容差 Capacitance Tolerance	±20%(20°C, 120Hz)																								
漏れ電流 Leakage Current (MAX)	I=0.01CV又は3µAのいずれか大なる値以下(定格電圧印加2分後) I=0.01CV or 3µA whichever is greater. (After 2 minutes) I=漏れ電流(µA) C=静電容量(µF) V=定格電圧(Vdc) Leakage Current Capacitance Rated Voltage																								
損失角の正接(tan δ) Dissipation Factor (MAX)	<table border="1"> <tr> <td>定格電圧(Vdc) Rated Voltage</td> <td>6.3</td> <td>10</td> <td>16</td> <td>25</td> <td>35</td> <td>50</td> <td>(20°C, 120Hz)</td> </tr> <tr> <td>tan δ</td> <td>0.22</td> <td>0.19</td> <td>0.16</td> <td>0.14</td> <td>0.12</td> <td>0.10</td> <td></td> </tr> </table> <p>1000µFを越えるものは1000µF増す毎に上表の値に0.02を加えた値とする。 When capacitance is over 1000µF, tan δ shall be added 0.02 to the listed value with increase of every 1000µF.</p>	定格電圧(Vdc) Rated Voltage	6.3	10	16	25	35	50	(20°C, 120Hz)	tan δ	0.22	0.19	0.16	0.14	0.12	0.10									
定格電圧(Vdc) Rated Voltage	6.3	10	16	25	35	50	(20°C, 120Hz)																		
tan δ	0.22	0.19	0.16	0.14	0.12	0.10																			
耐久性 Endurance	<p>105°C中で右表の時間定格電圧(リップル重畳)印加後、下記項目を満足すること。 After applying rated voltage with rated ripple current for specified time at 105°C, the capacitors shall meet the following requirements.</p> <table border="1"> <tr> <td>静電容量変化率 Capacitance Change</td> <td>初期値の±25%以内(6.3Vdc, 10Vdc: ±30%) Within ±25% of the initial value(6.3Vdc, 10Vdc: ±30%)</td> <td>ケースサイズ Case Size</td> <td>時間(hrs) Time(hrs)</td> </tr> <tr> <td>損失角の正接 Dissipation Factor</td> <td>規格値の200%以下 Not more than 200% of the specified value.</td> <td>5×11</td> <td>3000</td> </tr> <tr> <td>漏れ電流 Leakage Current</td> <td>規格値以下 Not more than the specified value.</td> <td>6.3×11, 8×11.5</td> <td>4000</td> </tr> <tr> <td></td> <td></td> <td>8×16, 8×20, 10×12.5</td> <td>5000</td> </tr> <tr> <td></td> <td></td> <td>φ10 L≥16, φD≥12.5</td> <td>6000</td> </tr> </table>	静電容量変化率 Capacitance Change	初期値の±25%以内(6.3Vdc, 10Vdc: ±30%) Within ±25% of the initial value(6.3Vdc, 10Vdc: ±30%)	ケースサイズ Case Size	時間(hrs) Time(hrs)	損失角の正接 Dissipation Factor	規格値の200%以下 Not more than 200% of the specified value.	5×11	3000	漏れ電流 Leakage Current	規格値以下 Not more than the specified value.	6.3×11, 8×11.5	4000			8×16, 8×20, 10×12.5	5000			φ10 L≥16, φD≥12.5	6000				
静電容量変化率 Capacitance Change	初期値の±25%以内(6.3Vdc, 10Vdc: ±30%) Within ±25% of the initial value(6.3Vdc, 10Vdc: ±30%)	ケースサイズ Case Size	時間(hrs) Time(hrs)																						
損失角の正接 Dissipation Factor	規格値の200%以下 Not more than 200% of the specified value.	5×11	3000																						
漏れ電流 Leakage Current	規格値以下 Not more than the specified value.	6.3×11, 8×11.5	4000																						
		8×16, 8×20, 10×12.5	5000																						
		φ10 L≥16, φD≥12.5	6000																						
低温特性 Low Temperature Stability (インピーダンス比) Impedance Ratio (MAX)	<table border="1"> <tr> <td>定格電圧(Vdc) Rated Voltage</td> <td>6.3</td> <td>10</td> <td>16</td> <td>25</td> <td>35</td> <td>50</td> <td>(120Hz)</td> </tr> <tr> <td>Z(-25°C)/Z(+20°C)</td> <td>4</td> <td>3</td> <td>2</td> <td>2</td> <td>2</td> <td>2</td> <td></td> </tr> <tr> <td>Z(-40°C)/Z(+20°C)</td> <td>8</td> <td>6</td> <td>4</td> <td>3</td> <td>3</td> <td>3</td> <td></td> </tr> </table>	定格電圧(Vdc) Rated Voltage	6.3	10	16	25	35	50	(120Hz)	Z(-25°C)/Z(+20°C)	4	3	2	2	2	2		Z(-40°C)/Z(+20°C)	8	6	4	3	3	3	
定格電圧(Vdc) Rated Voltage	6.3	10	16	25	35	50	(120Hz)																		
Z(-25°C)/Z(+20°C)	4	3	2	2	2	2																			
Z(-40°C)/Z(+20°C)	8	6	4	3	3	3																			

◆呼称方法/PART NUMBER

YXS M D x L
 定格電圧 シリーズ名 静電容量 静電容量許容差 副記号 リード加工記号 ケースサイズ
 Rated Voltage Series Capacitance Capacitance Tolerance Option Lead Forming Case Size

◆リップル電流補正係数/
MULTIPLIER FOR RIPPLE CURRENT

周波数(Hz) Frequency	120	1k	10k	100k≤
22~33µF	0.42	0.70	0.90	1.00
47~270µF	0.50	0.73	0.92	1.00
330~680µF	0.55	0.77	0.94	1.00
820~1800µF	0.60	0.80	0.96	1.00
2200~22000µF	0.70	0.85	0.98	1.00

◆副記号/OPTION

EFC : PETスリーブ PET Sleeve

◆寸法図／DIMENSIONS

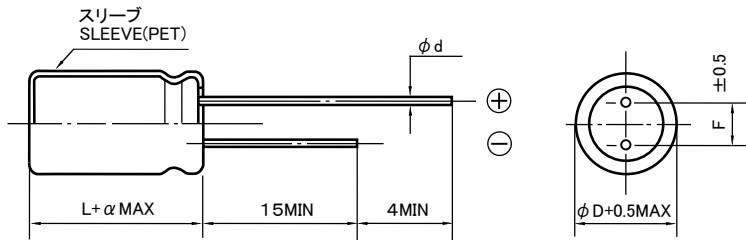

(mm)

φD	5	6.3	8	10	12.5	16	18
φd	0.5		0.6			0.8	
F	2.0	2.5	3.5	5.0		7.5	
α	L ≤ 16 : α = 1.5 L ≥ 20 : α = 2.0						

◆標準品一覧表／STANDARD SIZE

定格電圧 Rated Voltage (Vdc)	静電容量 Capacitance (μF)	外形寸法 Size φD × L (mm)	定格リップル 電流 Rated Ripple Current	インピーダンス (Ω MAX) Impedance	
				20°C, 100kHz	-10°C, 100kHz
6.3	150	5×11	210	0.58	2.3
	220	5×11	210	0.58	2.3
	330	6.3×11	340	0.22	0.87
	470	6.3×11	340	0.22	0.87
	680	8×11.5	730	0.12	0.48
	820	8×16	1050	0.069	0.27
	1000	8×11.5	730	0.120	0.48
	1200	8×16	1050	0.069	0.27
	1200	10×12.5	1210	0.060	0.24
	1500	10×16	1450	0.046	0.18
	1800	10×20	1720	0.037	0.15
	2200	10×20	1720	0.037	0.15
	2700	10×23	1910	0.031	0.12
	2700	12.5×16	1730	0.04	0.12
	3300	12.5×16	1730	0.04	0.12
	3900	12.5×20	2160	0.028	0.089
	3900	16×16	1940	0.042	0.110
	4700	12.5×25	2650	0.024	0.065
	5600	12.5×25	2650	0.024	0.065
	5600	12.5×30	2880	0.020	0.065
6800	12.5×35	3350	0.017	0.063	
6800	16×20	2540	0.021	0.06	
8200	16×25	3060	0.017	0.05	
10000	16×31.5	3610	0.017	0.044	
10000	18×20	2860	0.026	0.060	
12000	16×35.5	4080	0.015	0.038	
12000	18×25	3140	0.019	0.045	
15000	18×31.5	4170	0.015	0.038	
18000	18×35.5	4280	0.014	0.032	
22000	18×40	4550	0.012	0.030	
10	100	5×11	210	0.58	2.3
	220	5×11	210	0.58	2.3
	220	6.3×11	340	0.22	0.87
	470	6.3×11	340	0.22	0.87
	680	8×11.5	730	0.12	0.48
	680	8×16	1050	0.069	0.27
	1000	8×16	1050	0.069	0.27
	1000	10×12.5	1210	0.060	0.24
	1200	10×16	1450	0.046	0.18
	1500	8×20	1650	0.042	0.17
	1500	10×16	1450	0.046	0.18
	1500	10×20	1720	0.037	0.15
	1800	10×20	1720	0.037	0.15
	2200	10×23	1910	0.031	0.12
	2200	12.5×16	1730	0.04	0.12

Rated Ripple Current (mA r.m.s./105°C, 100kHz)

定格電圧 Rated Voltage (Vdc)	静電容量 Capacitance (μF)	外形寸法 Size φD × L (mm)	定格リップル 電流 Rated Ripple Current	インピーダンス (Ω MAX) Impedance	
				20°C, 100kHz	-10°C, 100kHz
10	2700	16×16	1940	0.042	0.110
	3300	12.5×20	2160	0.028	0.089
	3900	12.5×25	2650	0.024	0.065
	4700	12.5×30	2880	0.020	0.065
	5600	12.5×35	3350	0.017	0.063
	5600	16×20	2540	0.021	0.060
	6800	16×25	3060	0.017	0.050
	6800	18×20	2860	0.026	0.060
	8200	16×31.5	3610	0.017	0.044
	8200	18×25	3140	0.019	0.045
	10000	16×35.5	4080	0.015	0.038
	10000	18×31.5	4170	0.015	0.038
	12000	18×35.5	4280	0.014	0.032
	15000	18×40	4550	0.012	0.030
	16	56	5×11	210	0.58
120		5×11	210	0.58	2.3
330		6.3×11	340	0.22	0.87
470		8×11.5	730	0.12	0.48
470		8×16	1050	0.069	0.27
680		8×16	1050	0.069	0.27
680		10×12.5	1210	0.060	0.24
1000		8×20	1650	0.042	0.17
1000		10×16	1450	0.046	0.18
1000		10×20	1720	0.037	0.15
1200		10×20	1720	0.037	0.15
1500		10×20	1720	0.037	0.15
1500		10×23	1910	0.031	0.12
1500		12.5×16	1730	0.040	0.12
1800		10×23	1910	0.031	0.12
2200		10×25	2230	0.027	0.089
2200		12.5×20	2160	0.028	0.089
2200		16×16	1940	0.042	0.110
2700		12.5×25	2650	0.024	0.065
3300		12.5×30	2880	0.020	0.065
3900		12.5×35	3350	0.017	0.063
3900		16×20	2540	0.021	0.060
4700		16×25	3060	0.017	0.050
4700		18×20	2860	0.026	0.060
5600		16×31.5	3610	0.017	0.044
5600	18×25	3140	0.019	0.045	
6800	16×35.5	4080	0.015	0.038	
8200	18×31.5	4170	0.015	0.038	
10000	18×35.5	4280	0.014	0.032	
12000	18×40	4550	0.012	0.030	

◆標準品一覧表／STANDARD SIZE

Rated Ripple Current (mA r.m.s./105°C, 100kHz)

定格電圧 Rated Voltage (Vdc)	静電容量 Capacitance (μ F)	外形寸法 Size ϕ D×L (mm)	定格リプル 電流 RatedRipple Current	インピーダンス (Ω MAX) Impedance	
				20°C, 100kHz	-10°C, 100kHz
				25	47
100	5×11	210	0.58		2.3
220	6.3×11	340	0.22		0.87
330	8×11.5	730	0.12		0.48
330	8×16	1050	0.069		0.27
390	8×16	1050	0.069		0.27
470	8×16	1050	0.069		0.27
470	10×12.5	1210	0.060		0.24
560	8×20	1650	0.042		0.17
680	10×16	1450	0.046		0.18
680	10×20	1720	0.037		0.15
820	10×20	1720	0.037		0.15
1000	10×20	1720	0.037		0.15
1000	10×23	1910	0.031		0.12
1000	12.5×16	1730	0.040		0.12
1200	16×16	1940	0.042		0.11
1500	12.5×20	2160	0.028		0.089
1800	12.5×25	2650	0.024		0.065
2200	12.5×30	2880	0.020		0.065
2200	16×20	2540	0.021		0.060
2700	12.5×35	3350	0.017		0.063
2700	16×20	2540	0.021		0.060
3300	16×25	3060	0.017		0.050
3300	18×20	2860	0.026		0.060
3900	16×31.5	3610	0.017		0.044
3900	18×25	3140	0.019		0.045
4700	16×35.5	4080	0.015		0.038
4700	18×31.5	4170	0.015		0.038
5600	18×35.5	4280	0.014	0.032	
6800	18×40	4550	0.012	0.030	
35	33	5×11	210	0.58	2.3
	56	5×11	210	0.58	2.3
	150	8×11.5	730	0.12	0.48
	220	8×11.5	730	0.12	0.48
	220	8×16	1050	0.069	0.27
	270	8×16	1050	0.069	0.27
	330	10×12.5	1210	0.060	0.24
	390	8×20	1650	0.042	0.17
	470	10×16	1450	0.046	0.18
	470	10×20	1720	0.037	0.15
	560	10×20	1720	0.037	0.15
	680	10×23	1910	0.031	0.12
	680	12.5×16	1730	0.040	0.12
	1000	12.5×20	2160	0.028	0.089
	1000	16×16	1940	0.042	0.110
	1200	12.5×25	2650	0.024	0.065
	1500	12.5×30	2880	0.020	0.065
	1800	12.5×35	3350	0.017	0.063
	1800	16×20	2540	0.021	0.060
	2200	16×25	3060	0.017	0.050
2200	18×20	2860	0.026	0.060	

定格電圧 Rated Voltage (Vdc)	静電容量 Capacitance (μ F)	外形寸法 Size ϕ D×L (mm)	定格リプル 電流 RatedRipple Current	インピーダンス (Ω MAX) Impedance	
				20°C, 100kHz	-10°C, 100kHz
				35	2700
2700	18×25	3140	0.019		0.045
3300	16×35.5	4080	0.015		0.038
3300	18×31.5	4170	0.015		0.038
3900	18×35.5	4280	0.014		0.032
4700	18×40	4550	0.012		0.030
50	22	5×11	210		0.58
	56	6.3×11	340	0.22	0.87
	100	8×11.5	730	0.12	0.48
	120	8×11.5	730	0.12	0.48
	150	8×16	910	0.091	0.36
	180	8×16	910	0.091	0.36
	220	10×12.5	1050	0.084	0.34
	270	10×16	1220	0.060	0.24
	270	10×20	1440	0.055	0.22
	330	10×20	1440	0.055	0.22
	470	10×23	1690	0.043	0.17
	470	12.5×16	1670	0.045	0.15
	560	12.5×20	1950	0.034	0.11
	560	16×16	1830	0.054	0.15
	680	12.5×25	2510	0.025	0.083
	820	12.5×25	2510	0.025	0.083
	820	12.5×30	2680	0.024	0.077
	1000	12.5×35	2920	0.021	0.069
	1000	16×20	2460	0.025	0.075
	1200	16×25	2980	0.022	0.066
	1200	18×20	2490	0.030	0.070
	1500	16×31.5	3150	0.019	0.057
	1800	16×35.5	3710	0.016	0.048
	1800	18×25	3150	0.022	0.057
	2200	18×31.5	3680	0.018	0.046
	2700	18×35.5	3800	0.014	0.038
	3300	18×40	4170	0.013	0.033

ZLH series

105°C 6000~10000時間品 小形化 長寿命 低インピーダンス品
105°C 6000~10000 hours, Miniaturized, Long Life, Low Impedance

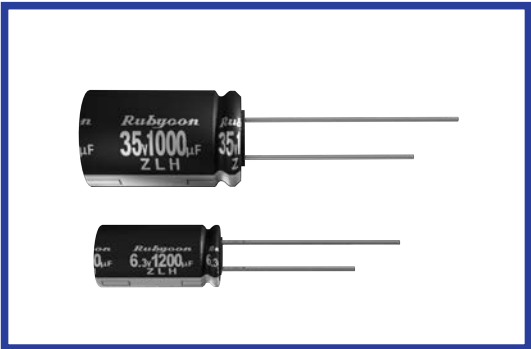

◆規格表/SPECIFICATIONS

項目 Item	特性 Characteristics	
カテゴリ温度範囲 Category Temperature Range	-40~+105°C	
定格電圧範囲 Rated Voltage Range	6.3~100Vdc	
静電容量許容差 Capacitance Tolerance	±20%(20°C, 120Hz)	
漏れ電流 Leakage Current (MAX)	I=0.01CV又は3µAのいずれか大なる値以下(定格電圧印加2分後) I=0.01CV or 3µA whichever is greater. (After 2 minutes) I=漏れ電流(µA) C=静電容量(µF) V=定格電圧(Vdc) Leakage Current Capacitance Rated Voltage	
損失角の正接(tan δ) Dissipation Factor (MAX)	定格電圧(Vdc) Rated Voltage	6.3 10 16 25 35 50 63 80 100 (20°C, 120Hz)
	tan δ	0.22 0.19 0.16 0.14 0.12 0.10 0.09 0.08 0.08
1000µFを越えるものは1000µF増す毎に上表の値に0.02を加えた値とする。 When capacitance is over 1000µF, tan δ shall be added 0.02 to the listed value with increase of every 1000µF.		
耐久性 Endurance	105°C中で右表の時間定格電圧(リップル重畳)印加後、下記項目を満足すること。 After applying rated voltage with rated ripple current for specified time at 105°C, the capacitors shall meet the following requirements.	
	静電容量変化率 Capacitance Change	初期値の±25%以内(6.3Vdc, 10Vdc: ±30%) Within ±25% of the initial value(6.3Vdc, 10Vdc: ±30%)
	損失角の正接 Dissipation Factor	規格値の200%以下 Not more than 200% of the specified value.
	漏れ電流 Leakage Current	規格値以下 Not more than the specified value.
	ケースサイズ Case Size	時間(hrs) Time(hrs)
	φD ≤ 6.3	6000
	φD = 8	8000
	φD ≥ 10	10000
低温特性 Low Temperature Stability (インピーダンス比) Impedance Ratio (MAX)	定格電圧(Vdc) Rated Voltage	6.3 10 16 25 35 50 63 80 100 (120Hz)
	Z(-25°C)/Z(+20°C)	2 2 2 2 2 2 2 2 2
	Z(-40°C)/Z(+20°C)	3 3 3 3 3 3 3 3 3

◆呼称方法/PART NUMBER

□□□ ZLH □□□□□ M □□□ □□ D x L
 定格電圧 シリーズ名 静電容量 静電容量許容差 副記号 リード加工記号 ケースサイズ
 Rated Voltage Series Capacitance Capacitance Tolerance Option Lead Forming Case Size

◆リップル電流補正係数/

MULTIPLIER FOR RIPPLE CURRENT

周波数(Hz) Frequency	120	1k	10k	100k ≤	
係数 Coefficient	8.2~33µF	0.42	0.70	0.90	1.00
	47~270µF	0.50	0.73	0.92	1.00
	330~680µF	0.55	0.77	0.94	1.00
	820~1800µF	0.60	0.80	0.96	1.00
	2200~8200µF	0.70	0.85	0.98	1.00

◆副記号/OPTION

EFC : PETスリーブ PET Sleeve

◆寸法図／DIMENSIONS

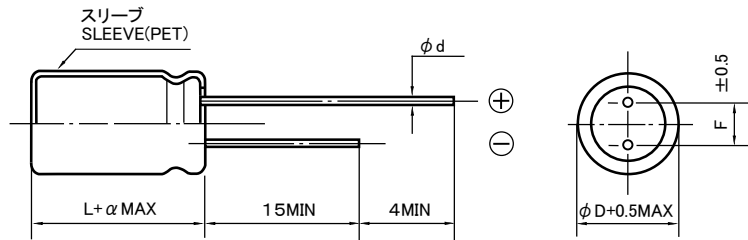

(mm)

ϕD	5	6.3	8	10	12.5	16	18
ϕd	0.5		0.6			0.8	
F	2.0	2.5	3.5	5.0		7.5	
α	L ≤ 16 : $\alpha = 1.5$ L ≥ 20 : $\alpha = 2.0$						

◆標準品一覧表／STANDARD SIZE

Rated Ripple Current (mA r.m.s./105°C, 100kHz)

定格電圧 Rated Voltage (Vdc)	静電容量 Capacitance (μF)	外形寸法 Size $\phi D \times L$ (mm)	定格リップル 電流 Rated Ripple Current	インピーダンス (Ω MAX) Impedance	
				20°C, 100kHz	-10°C, 100kHz
				6.3	220
	470	6.3x11	540	0.094	0.35
	820	8x11.5	945	0.056	0.19
	1200	8x16	1250	0.045	0.15
	1200	10x12.5	1330	0.039	0.14
	1500	8x20	1500	0.029	0.11
	1800	10x16	1760	0.028	0.10
	2200	10x20	1960	0.020	0.060
	2700	10x23	2250	0.018	0.054
	3900	12.5x20	2480	0.017	0.043
	4700	12.5x25	2900	0.015	0.038
	5600	12.5x30	3450	0.013	0.033
	6800	16x20	3250	0.015	0.038
	6800	12.5x35	3570	0.012	0.031
	8200	16x25	3630	0.013	0.035
10	150	5x11	345	0.22	0.80
	330	6.3x11	540	0.094	0.35
	680	8x11.5	945	0.056	0.19
	1000	8x16	1250	0.045	0.15
	1000	10x12.5	1330	0.039	0.14
	1500	8x20	1500	0.029	0.11
	1500	10x16	1760	0.028	0.10
	1800	10x20	1960	0.020	0.060
	2200	10x23	2250	0.018	0.054
	3300	12.5x20	2480	0.017	0.043
	3900	12.5x25	2900	0.015	0.038
	4700	12.5x30	3450	0.013	0.033
	4700	16x20	3250	0.015	0.038
	5600	12.5x35	3570	0.012	0.031
	6800	16x25	3630	0.013	0.035
16	100	5x11	345	0.22	0.80
	220	6.3x11	540	0.094	0.35
	470	8x11.5	945	0.056	0.19
	680	8x16	1250	0.045	0.15
	680	10x12.5	1330	0.039	0.14
	1000	8x20	1500	0.029	0.11
	1000	10x16	1760	0.028	0.10
	1500	10x20	1960	0.020	0.060
	1800	10x23	2250	0.018	0.054
	2200	12.5x20	2480	0.017	0.043
	2700	12.5x25	2900	0.015	0.038
	3300	12.5x30	3450	0.013	0.033
	3300	16x20	3250	0.015	0.038
	3900	12.5x35	3570	0.012	0.031
	4700	16x25	3630	0.013	0.035

定格電圧 Rated Voltage (Vdc)	静電容量 Capacitance (μF)	外形寸法 Size $\phi D \times L$ (mm)	定格リップル 電流 Rated Ripple Current	インピーダンス (Ω MAX) Impedance	
				20°C, 100kHz	-10°C, 100kHz
				25	68
	150	6.3x11	540	0.094	0.35
	330	8x11.5	945	0.056	0.19
	390	8x16	1250	0.045	0.15
	470	10x12.5	1330	0.039	0.14
	560	8x20	1500	0.029	0.11
	680	10x16	1760	0.028	0.10
	820	10x20	1960	0.020	0.060
	1000	10x23	2250	0.018	0.054
	1500	12.5x20	2480	0.017	0.043
	1800	12.5x25	2900	0.015	0.038
	2200	12.5x30	3450	0.013	0.033
	2200	16x20	3250	0.015	0.038
	2700	12.5x35	3570	0.012	0.031
	3300	16x25	3630	0.013	0.035
35	47	5x11	345	0.220	0.80
	100	6.3x11	540	0.094	0.35
	220	8x11.5	945	0.056	0.19
	270	8x16	1250	0.045	0.15
	330	10x12.5	1330	0.039	0.14
	390	8x20	1500	0.029	0.11
	470	10x16	1760	0.028	0.10
	560	10x20	1960	0.020	0.060
	680	10x23	2250	0.018	0.054
	1000	12.5x20	2480	0.017	0.043
	1200	12.5x25	2900	0.015	0.038
	1500	12.5x30	3450	0.013	0.033
	1500	16x20	3250	0.015	0.038
	1800	12.5x35	3570	0.012	0.031
	2200	16x25	3630	0.013	0.035
50	27	5x11	238	0.34	1.18
	56	6.3x11	385	0.14	0.50
	100	8x11.5	724	0.074	0.22
	120	8x16	950	0.061	0.18
	150	10x12.5	979	0.061	0.18
	180	8x20	1190	0.046	0.14
	220	10x16	1370	0.042	0.12
	270	10x20	1580	0.030	0.09
	330	10x23	1870	0.028	0.085
	470	12.5x20	2050	0.027	0.068
	560	12.5x25	2410	0.023	0.059
	680	12.5x30	2860	0.021	0.052
	820	12.5x35	2960	0.019	0.051
	820	16x20	2730	0.023	0.059
	1000	16x25	3010	0.021	0.056

◆標準品一覧表／STANDARD SIZE

Rated Ripple Current (mA r.m.s./105°C, 100kHz)

定格電圧 Rated Voltage (Vdc)	静電容量 Capacitance (μ F)	外形寸法 Size ϕ D×L (mm)	定格リップル 電流 RatedRipple Current	インピーダンス (Ω MAX) Impedance	
				20°C, 100kHz	-10°C, 100kHz
				63	18
47	6.3×11	278	0.35		1.4
82	8×11.5	525	0.22		0.88
100	8×16	688	0.16		0.64
120	10×12.5	725	0.15		0.6
150	8×20	861	0.12		0.48
180	10×16	998	0.11		0.44
270	10×20	1200	0.078		0.31
270	12.5×16	1200	0.082		0.27
330	10×23	1410	0.069		0.28
390	12.5×20	1570	0.060		0.19
470	12.5×25	1990	0.043		0.14
560	12.5×30	2410	0.035		0.13
560	16×20	2100	0.043		0.14
680	12.5×35	2620	0.033		0.11
820	12.5×40	2940	0.027		0.09
820	16×25	2730	0.032		0.096
820	18×20	2500	0.038		0.100
1200	16×31.5	2990	0.024		0.068
1200	18×25	2800	0.031		0.084
1500	16×35.5	3040	0.021		0.057
1500	18×31.5	3300	0.025		0.068
1800	16×40	3570	0.019		0.057
1800	18×35.5	3570	0.020		0.054
2200	18×40	3670	0.018	0.049	
80	12	5×11	163	1.4	5.6
	33	6.3×11	267	0.57	2.3
	56	8×11.5	462	0.36	1.4
	68	8×16	585	0.25	1.0
	82	10×12.5	624	0.23	0.96
	100	8×20	735	0.19	0.76
	120	10×16	780	0.17	0.72
	180	10×20	1040	0.12	0.52
	180	12.5×16	975	0.13	0.43
	220	10×23	1170	0.11	0.47
	270	12.5×20	1430	0.085	0.31
	330	12.5×25	1620	0.060	0.23
	390	12.5×30	1950	0.051	0.21
	390	16×20	1750	0.058	0.21
	470	12.5×35	2140	0.043	0.17
	560	12.5×40	2340	0.036	0.15
	560	16×25	2210	0.044	0.16
	560	18×20	1950	0.054	0.18
	680	16×31.5	2400	0.033	0.12
	820	16×35.5	2600	0.029	0.10
	820	18×25	2270	0.038	0.13
	1000	16×40	2860	0.027	0.09
	1000	18×31.5	2470	0.031	0.11
	1200	18×35.5	2860	0.027	0.084
1500	18×40	3510	0.026	0.076	

定格電圧 Rated Voltage (Vdc)	静電容量 Capacitance (μ F)	外形寸法 Size ϕ D×L (mm)	定格リップル 電流 RatedRipple Current	インピーダンス (Ω MAX) Impedance	
				20°C, 100kHz	-10°C, 100kHz
				100	8.2
18	6.3×11	267	0.57		2.3
33	8×11.5	462	0.36		1.4
47	8×16	585	0.25		1.0
56	10×12.5	624	0.23		0.96
68	8×20	735	0.19		0.76
82	10×16	780	0.17		0.72
100	10×20	1040	0.12		0.52
100	12.5×16	975	0.13		0.43
120	10×23	1170	0.11		0.47
150	12.5×20	1430	0.085		0.31
220	12.5×25	1620	0.060		0.23
270	12.5×30	1950	0.051		0.21
270	16×20	1750	0.058		0.21
330	12.5×35	2140	0.043		0.17
390	12.5×40	2340	0.036		0.15
390	16×25	2210	0.044		0.16
390	18×20	1950	0.054		0.18
470	16×31.5	2400	0.033		0.12
470	18×25	2270	0.038		0.13
560	16×35.5	2600	0.029		0.10
560	18×31.5	2470	0.031		0.11
680	16×40	2860	0.027		0.09
680	18×35.5	2860	0.027		0.084
820	18×40	3510	0.026	0.076	

ZLJ series

105°C 6000~10000時間品 高リップル 長寿命 低インピーダンス品
105°C 6000~10000 hours, High Ripple Current, Long Life, Low Impedance

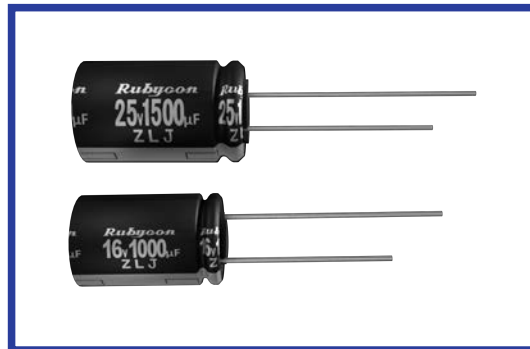

◆規格表/SPECIFICATIONS

項目 Item	特性 Characteristics																																																	
カテゴリ温度範囲 Category Temperature Range	-40~+105°C																																																	
定格電圧範囲 Rated Voltage Range	6.3~120Vdc																																																	
静電容量許容差 Capacitance Tolerance	±20%(20°C, 120Hz)																																																	
漏れ電流 Leakage Current (MAX)	I=0.01CV又は3µAのいずれか大なる値以下(定格電圧印加2分後) I=0.01CV or 3µA whichever is greater. (After 2 minutes) I=漏れ電流(µA) C=静電容量(µF) V=定格電圧(Vdc) Leakage Current Capacitance Rated Voltage																																																	
損失角の正接(tan δ) Dissipation Factor (MAX)	<table border="1"> <thead> <tr> <th>定格電圧 (Vdc) Rated Voltage</th> <th>6.3</th> <th>10</th> <th>16</th> <th>25</th> <th>35</th> <th>50</th> <th>63</th> <th>80</th> <th>100</th> <th>120</th> <th>(20°C, 120Hz)</th> </tr> </thead> <tbody> <tr> <td>tan δ</td> <td>0.22</td> <td>0.19</td> <td>0.16</td> <td>0.14</td> <td>0.12</td> <td>0.10</td> <td>0.09</td> <td>0.08</td> <td>0.08</td> <td>0.08</td> <td></td> </tr> </tbody> </table>	定格電圧 (Vdc) Rated Voltage	6.3	10	16	25	35	50	63	80	100	120	(20°C, 120Hz)	tan δ	0.22	0.19	0.16	0.14	0.12	0.10	0.09	0.08	0.08	0.08		1000µFを超えるものは1000µF増す毎に上記の表に0.02を加えた値とする。																								
定格電圧 (Vdc) Rated Voltage	6.3	10	16	25	35	50	63	80	100	120	(20°C, 120Hz)																																							
tan δ	0.22	0.19	0.16	0.14	0.12	0.10	0.09	0.08	0.08	0.08																																								
耐久性 Endurance	<p>105°C中で右表の時間定格電圧(リップル重畳)印加後、下記規格を満足すること。 After applying rated voltage with rated ripple current for specified time at 105°C, the capacitors shall meet the following requirements.</p> <table border="1"> <thead> <tr> <th rowspan="2">静電容量変化率 Capacitance Change</th> <th rowspan="2">初期値の ±25%以内 (6.3Vdc, 10Vdc: ±30%) Within ±25% of the initial value.</th> <th colspan="4">ケースサイズ Case Size</th> <th colspan="4">時間(hrs) Life Time</th> </tr> <tr> <th>6.3Vdc</th> <th>10~50Vdc</th> <th>63~100Vdc</th> <th>120Vdc</th> <th>6.3Vdc</th> <th>10~50Vdc</th> <th>63~100Vdc</th> <th>120Vdc</th> </tr> </thead> <tbody> <tr> <td>損失角の正接 Dissipation Factor</td> <td>規格値の200%以下 Not more than 200% of the specified value.</td> <td>φD ≤ 6.3</td> <td>8X11.5</td> <td>10X12.5</td> <td>8X16, 8X20</td> <td>10X16, 10X20, 10X25</td> <td>φD ≥ 12.5</td> <td>6000</td> <td>7000</td> <td>8000</td> <td>9000</td> <td>9000</td> <td>9000</td> <td>9000</td> <td>10000</td> </tr> <tr> <td>漏れ電流 Leakage Current</td> <td>規格値以下 Not more than the specified value.</td> <td colspan="4"></td> <td colspan="4">10000</td> <td colspan="4"></td> </tr> </tbody> </table>		静電容量変化率 Capacitance Change	初期値の ±25%以内 (6.3Vdc, 10Vdc: ±30%) Within ±25% of the initial value.	ケースサイズ Case Size				時間(hrs) Life Time				6.3Vdc	10~50Vdc	63~100Vdc	120Vdc	6.3Vdc	10~50Vdc	63~100Vdc	120Vdc	損失角の正接 Dissipation Factor	規格値の200%以下 Not more than 200% of the specified value.	φD ≤ 6.3	8X11.5	10X12.5	8X16, 8X20	10X16, 10X20, 10X25	φD ≥ 12.5	6000	7000	8000	9000	9000	9000	9000	10000	漏れ電流 Leakage Current	規格値以下 Not more than the specified value.					10000							
静電容量変化率 Capacitance Change	初期値の ±25%以内 (6.3Vdc, 10Vdc: ±30%) Within ±25% of the initial value.	ケースサイズ Case Size				時間(hrs) Life Time																																												
		6.3Vdc	10~50Vdc	63~100Vdc	120Vdc	6.3Vdc	10~50Vdc	63~100Vdc	120Vdc																																									
損失角の正接 Dissipation Factor	規格値の200%以下 Not more than 200% of the specified value.	φD ≤ 6.3	8X11.5	10X12.5	8X16, 8X20	10X16, 10X20, 10X25	φD ≥ 12.5	6000	7000	8000	9000	9000	9000	9000	10000																																			
漏れ電流 Leakage Current	規格値以下 Not more than the specified value.					10000																																												
低温特性 Low Temperature Stability (インピーダンス比) Impedance Ratio (MAX)	<table border="1"> <thead> <tr> <th>定格電圧 (Vdc) Rated Voltage</th> <th>6.3</th> <th>10</th> <th>16</th> <th>25</th> <th>35</th> <th>50</th> <th>63</th> <th>80</th> <th>100</th> <th>120</th> <th>(120Hz)</th> </tr> </thead> <tbody> <tr> <td>Z(-25°C)/Z(+20°C)</td> <td>2</td> <td>2</td> <td>2</td> <td>2</td> <td>2</td> <td>2</td> <td>2</td> <td>2</td> <td>2</td> <td>3</td> <td></td> </tr> <tr> <td>Z(-40°C)/Z(+20°C)</td> <td>3</td> <td>3</td> <td>3</td> <td>3</td> <td>3</td> <td>3</td> <td>3</td> <td>3</td> <td>3</td> <td>4</td> <td></td> </tr> </tbody> </table>	定格電圧 (Vdc) Rated Voltage	6.3	10	16	25	35	50	63	80	100	120	(120Hz)	Z(-25°C)/Z(+20°C)	2	2	2	2	2	2	2	2	2	3		Z(-40°C)/Z(+20°C)	3	3	3	3	3	3	3	3	3	4														
定格電圧 (Vdc) Rated Voltage	6.3	10	16	25	35	50	63	80	100	120	(120Hz)																																							
Z(-25°C)/Z(+20°C)	2	2	2	2	2	2	2	2	2	3																																								
Z(-40°C)/Z(+20°C)	3	3	3	3	3	3	3	3	3	4																																								

◆呼称方法/PART NUMBER

□□□ ZLJ □□□□□ M □□□ □□ D x L
 定格電圧 シリーズ名 静電容量 静電容量許容差 副記号 リード加工記号 ケースサイズ
 Rated Voltage Series Capacitance Capacitance Tolerance Option Lead Forming Case Size

◆リップル電流補正係数/
MULTIPLIER FOR RIPPLE CURRENT

周波数 (Hz) Frequency	120	1k	10k	100k ≤
8.2~33 µF	0.42	0.70	0.90	1.00
47~270 µF	0.50	0.73	0.92	1.00
330~680 µF	0.55	0.77	0.94	1.00
820~1800 µF	0.60	0.80	0.96	1.00
2200~8200 µF	0.70	0.85	0.98	1.00

◆副記号/OPTION

Blank : 標準品
 EFU : 低インピーダンス仕様品
 Blank : Standard item
 EFU : Low Impedance items

◆寸法図/DIMENSIONS

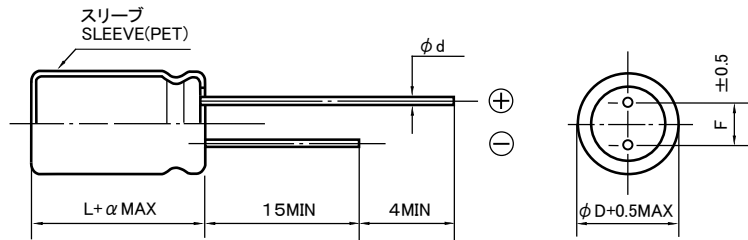

ϕD	5	6.3	8	10	12.5	16	18
ϕd	0.5		0.6			0.8	
F	2.0	2.5	3.5	5.0		7.5	
α	L ≤ 16 : $\alpha = 1.5$ L ≥ 20 : $\alpha = 2.0$						

◆標準品一覧表/STANDARD SIZE

定格電圧 Rated Voltage (Vdc)	静電容量 Capacitance (μF)	外形寸法 Size $\phi D \times L$ (mm)	定格リップル 電流 Rated Ripple Current	インピーダンス (Ω MAX) Impedance	
				20°C, 100kHz	-10°C, 100kHz
				6.3	220
	470	6.3x11	540	0.17	0.51
	820	8x11.5	945	0.075	0.23
	1000	8x16	1250	0.059	0.18
	1200	10x12.5	1330	0.053	0.16
	1500	8x20	1500	0.041	0.13
	1800	10x16	1760	0.038	0.12
	2700	10x20	1960	0.028	0.084
	3300	10x25	2250	0.024	0.072
	3900	12.5x20	2480	0.025	0.075
	4700	12.5x25	2900	0.019	0.057
	5600	12.5x30	3450	0.018	0.054
	6800	12.5x35	3570	0.016	0.048
	6800	16x20	3250	0.021	0.063
	8200	16x25	3630	0.017	0.051
10	150	5x11	450	0.40	1.2
	330	6.3x11	700	0.17	0.51
	560	8x11.5	1200	0.075	0.23
	680	8x16	1600	0.059	0.18
	820	10x12.5	1700	0.053	0.16
	1000	8x20	1960	0.041	0.13
	1200	10x16	2000	0.038	0.12
	2200	10x25	2900	0.024	0.072
	2700	12.5x20	2600	0.025	0.075
	3300	12.5x25	3200	0.019	0.057
	4700	12.5x30	3660	0.018	0.054
	4700	16x20	3330	0.021	0.063
	5600	12.5x35	4120	0.016	0.048
	5600	16x25	3810	0.017	0.051
16	120	5x11	450	0.40	1.2
	270	6.3x11	700	0.17	0.51
	470	8x11.5	1200	0.075	0.23
	560	8x16	1600	0.059	0.18
	680	8x16	1600	0.059	0.18
	680	10x12.5	1700	0.053	0.16
	820	8x20	1960	0.041	0.13
	1000	8x20	1960	0.041	0.13
	1000	10x16	2000	0.038	0.12
	1500	10x20	2500	0.028	0.084
	1800	10x25	2900	0.024	0.072
	2200	12.5x20	2600	0.025	0.075
	2700	12.5x25	3200	0.019	0.057
	3300	12.5x30	3660	0.018	0.054
	3300	16x20	3330	0.021	0.063
	3900	12.5x35	4120	0.016	0.048
	4700	16x25	3810	0.017	0.051

Rated Ripple Current (mA r.m.s./105°C, 100kHz)

定格電圧 Rated Voltage (Vdc)	静電容量 Capacitance (μF)	外形寸法 Size $\phi D \times L$ (mm)	定格リップル 電流 Rated Ripple Current	インピーダンス (Ω MAX) Impedance	
				20°C, 100kHz	-10°C, 100kHz
				25	68
	150	6.3x11	700	0.17	0.51
	330	8x11.5	1200	0.075	0.23
	390	8x16	1600	0.059	0.18
	470	10x12.5	1700	0.053	0.16
	560	8x20	1960	0.041	0.13
	680	10x16	2000	0.038	0.12
	1000	10x20	2500	0.028	0.084
	1200	10x25	2900	0.024	0.072
	1500	12.5x20	2600	0.025	0.075
	1800	12.5x25	3200	0.019	0.057
	2200	12.5x30	3660	0.018	0.054
	2200	16x20	3330	0.021	0.063
	2700	12.5x35	4120	0.016	0.048
	3300	16x25	3810	0.017	0.051
35	47	5x11	450	0.40	1.2
	100	6.3x11	700	0.17	0.51
	180	8x11.5	1200	0.075	0.23
	220	8x16	1600	0.059	0.18
	270	8x16	1600	0.059	0.18
	270	10x12.5	1700	0.053	0.16
	330	8x20	1960	0.041	0.13
	330	10x12.5	1700	0.053	0.16
	390	8x20	1960	0.041	0.13
	390	10x16	2000	0.038	0.12
	470	10x16	2000	0.038	0.12
	560	10x20	2500	0.028	0.084
	680	10x25	2900	0.024	0.072
	820	12.5x20	2600	0.025	0.075
	1000	12.5x20	2600	0.025	0.075
	1200	12.5x25	3200	0.019	0.057
	1500	12.5x30	3660	0.018	0.054
	1500	16x20	3330	0.021	0.063
	1800	12.5x35	4120	0.016	0.048
	1800	16x25	3810	0.017	0.051
50	27	5x11	310	0.48	1.5
	56	6.3x11	500	0.22	0.66
	100	8x11.5	950	0.12	0.36
	120	8x11.5	1300	0.11	0.33
	120	8x16	1230	0.082	0.25
	150	10x12.5	1280	0.073	0.22
	180	8x16	1700	0.081	0.24
	180	8x20	1580	0.058	0.18
	220	10x12.5	1700	0.071	0.21
	220	10x16	1650	0.053	0.16
	270	8x20	2100	0.058	0.17
	330	10x16	2100	0.052	0.16

◆標準品一覧表 / STANDARD SIZE

Rated Ripple Current (mA r.m.s./105°C, 100kHz)

定格電圧 Rated Voltage (Vdc)	静電容量 Capacitance (μF)	外形寸法 Size φD × L (mm)	定格リップル電流 Rated Ripple Current	インピーダンス (Ω MAX) Impedance		
				20°C, 100kHz	-10°C, 100kHz	
				50	330	10×20
390	10×25	2420	0.032		0.10	
470	10×20	2500	0.037		0.11	
470	12.5×16	2200	0.040		0.12	
470	12.5×20	2300	0.032		0.10	
560	10×25	2900	0.031		0.093	
680	12.5×20	2700	0.029		0.087	
680	12.5×25	2800	0.025		0.080	
820	12.5×30	3370	0.023		0.074	
820	16×20	3070	0.026		0.084	
1000	12.5×25	3000	0.022		0.066	
1000	12.5×30	3500	0.020		0.060	
1000	12.5×35	3810	0.021		0.067	
1000	16×25	3510	0.022		0.070	
1200	12.5×35	4000	0.017		0.051	
1200	16×20	3100	0.023		0.069	
1500	12.5×40	4500	0.019		0.057	
1500	16×25	3600	0.018		0.054	
1500	18×20	3200	0.029		0.087	
2200	16×31.5	4100	0.018		0.054	
2200	18×25	3700	0.022		0.066	
2700	16×35.5	4400	0.016		0.048	
2700	16×40	4800	0.014		0.042	
2700	18×31.5	4200	0.019		0.057	
3300	18×35.5	4600	0.016		0.048	
3900	18×40	5000	0.014		0.042	
63	18	5×11	240		0.71	3.2
	47	6.3×11	420		0.28	1.3
	82	8×11.5	720	0.18	0.79	
	100	8×11.5	1000	0.13	0.39	
	100	8×16	990	0.13	0.58	
	120	8×16	1300	0.095	0.29	
	120	10×12.5	990	0.110	0.44	
	150	8×20	1200	0.096	0.43	
	150	10×12.5	1300	0.080	0.24	
	180	8×20	1600	0.069	0.21	
	180	10×16	1200	0.076	0.31	
	220	10×16	1700	0.058	0.17	
	270	10×20	1570	0.056	0.23	
	270	12.5×16	1570	0.072	0.27	
	330	10×20	2000	0.042	0.13	
	330	10×25	1990	0.046	0.19	
	330	12.5×16	1900	0.045	0.14	
	390	10×25	2400	0.035	0.11	
	390	12.5×20	1990	0.041	0.13	
	470	12.5×20	2400	0.033	0.099	
	470	12.5×25	2460	0.031	0.093	
	560	12.5×30	2760	0.028	0.084	
	560	16×20	2380	0.032	0.096	
	680	12.5×25	2800	0.025	0.075	
	680	12.5×35	3040	0.024	0.072	
	820	12.5×30	3200	0.022	0.066	
	820	16×20	2900	0.025	0.075	
	820	16×25	2890	0.025	0.075	
	1000	12.5×35	3500	0.018	0.054	
	1000	16×25	3200	0.020	0.060	
	1200	12.5×40	3800	0.021	0.063	
	1200	18×20	3000	0.032	0.096	
1500	16×31.5	3500	0.020	0.060		

定格電圧 Rated Voltage (Vdc)	静電容量 Capacitance (μF)	外形寸法 Size φD × L (mm)	定格リップル電流 Rated Ripple Current	インピーダンス (Ω MAX) Impedance		
				20°C, 100kHz	-10°C, 100kHz	
				63	1500	18×25
1800	16×35.5	3800	0.017		0.051	
1800	18×31.5	3700	0.020		0.060	
2200	16×40	4100	0.015		0.045	
2200	18×35.5	3900	0.017		0.051	
2700	18×40	4300	0.015		0.045	
80	12	5×11	235		0.72	3.2
	12	5×11	220		1.20	5.4
	27	6.3×11	390	0.34	1.5	
	27	6.3×11	370	0.46	2.1	
	47	8×11.5	650	0.20	0.9	
	47	8×11.5	620	0.29	1.3	
	56	8×16	780	0.20	0.9	
	68	10×12.5	780	0.17	0.66	
	82	8×16	820	0.14	0.63	
	82	8×20	1040	0.16	0.66	
	100	10×12.5	860	0.14	0.56	
	100	10×16	1040	0.11	0.47	
	120	8×20	1090	0.12	0.54	
	150	10×16	1150	0.09	0.36	
	150	10×20	1430	0.084	0.34	
	150	12.5×16	1430	0.110	0.34	
	180	10×25	1620	0.069	0.28	
	220	10×20	1570	0.068	0.28	
	220	12.5×16	1430	0.090	0.27	
	220	12.5×20	1750	0.062	0.18	
	270	10×25	1780	0.055	0.22	
	270	12.5×25	2210	0.047	0.14	
	330	12.5×20	1800	0.048	0.15	
	330	12.5×30	2400	0.042	0.13	
	330	16×20	1950	0.048	0.15	
	390	12.5×25	2210	0.038	0.12	
	390	12.5×35	2600	0.036	0.11	
	470	12.5×30	2520	0.033	0.11	
	470	12.5×40	2860	0.032	0.095	
	470	16×20	2150	0.036	0.120	
	470	16×25	2430	0.038	0.120	
	470	18×20	2270	0.045	0.140	
	560	12.5×35	2860	0.026	0.078	
	560	16×31.5	2640	0.032	0.095	
	680	16×25	2620	0.028	0.084	
	680	18×20	2280	0.032	0.096	
	680	16×35.5	2860	0.029	0.086	
	680	18×25	2500	0.036	0.110	
	820	16×31.5	2900	0.022	0.066	
	820	16×40	3510	0.027	0.081	
820	18×31.5	2860	0.030	0.090		
1000	16×35.5	3150	0.020	0.060		
1000	18×25	2750	0.027	0.081		
1000	18×35.5	3510	0.027	0.081		
1200	16×40	3710	0.018	0.054		
1200	18×31.5	3150	0.020	0.060		
1200	18×40	3860	0.026	0.076		
1500	18×35.5	3710	0.018	0.054		
1800	18×40	4060	0.017	0.051		

● : 副記号 EFUとなります。
● : OPTION has EFU

◆標準品一覧表／STANDARD SIZE

Rated Ripple Current (mA r.m.s./105°C, 100kHz)

定格電圧 Rated Voltage (Vdc)	静電容量 Capacitance (μF)	外形寸法 Size φD×L (mm)	定格リップル 電流 RatedRipple Current	インピーダンス (Ω MAX) Impedance	
				20°C, 100kHz	-10°C, 100kHz
				100	8.2 ●
8.2	5×11	220	1.2		5.4
18 ●	6.3×11	390	0.34		1.5
18	6.3×11	370	0.46		2.1
33 ●	8×11.5	650	0.2		0.9
33	8×11.5	620	0.29		1.3
47 ●	8×16	820	0.14		0.63
47	8×16	780	0.20		0.90
56 ●	10×12.5	860	0.14		0.56
56	10×12.5	780	0.17		0.66
68 ●	8×20	1090	0.12		0.54
68	8×20	1040	0.16		0.66
82 ●	10×16	1150	0.09		0.36
82	10×16	1040	0.11		0.47
100	10×20	1430	0.084		0.34
100	12.5×16	1430	0.11		0.34
120	10×20	1570	0.068		0.28
120	10×25	1620	0.069		0.28
120	12.5×16	1430	0.090		0.27
150	10×25	1780	0.055		0.22
150	12.5×20	1750	0.062		0.18
180	12.5×20	1800	0.048		0.15
220 ●	12.5×25	2210	0.038		0.12
220	12.5×25	2210	0.047		0.14
270 ●	12.5×30	2520	0.033		0.11
270	12.5×30	2400	0.042		0.13
270	16×20	1950	0.048		0.15
330	12.5×35	2600	0.036		0.11
330	16×20	2150	0.036		0.12
390	12.5×35	2860	0.026		0.078
390	12.5×40	2860	0.032		0.095
390 ●	16×25	2620	0.028		0.084
390	16×25	2430	0.038		0.120
390 ●	18×20	2280	0.032		0.096
390	18×20	2270	0.045		0.140
470	16×31.5	2640	0.032		0.095
470	18×25	2500	0.036		0.110
560	16×31.5	2900	0.022		0.066
560	16×35.5	2860	0.029		0.086
560	18×25	2750	0.027		0.081
560	18×31.5	2860	0.030	0.090	
680	16×35.5	3150	0.020	0.060	
680	16×40	3510	0.027	0.081	
680	18×31.5	3150	0.020	0.060	
680	18×35.5	3510	0.027	0.081	
820	16×40	3710	0.018	0.054	
820	18×35.5	3710	0.018	0.054	
820	18×40	3860	0.026	0.076	
1000	18×40	4060	0.017	0.051	

定格電圧 Rated Voltage (Vdc)	静電容量 Capacitance (μF)	外形寸法 Size φD×L (mm)	定格リップル 電流 RatedRipple Current	インピーダンス (Ω MAX) Impedance	
				20°C, 100kHz	-10°C, 100kHz
				120	33
47	8×20	735	0.19		0.76
56	10×16	780	0.17		0.72
82	10×20	1040	0.12		0.52
100	10×25	1250	0.10		0.43
120	10×28	1400	0.09		0.38
120	12.5×20	1430	0.085		0.31
150	12.5×25	1620	0.21		0.84
180	12.5×30	1880	0.18		0.72
180	16×20	1700	0.17		0.65
220	12.5×35	2140	0.15		0.60
270	12.5×40	2340	0.12		0.48
270	16×25	2100	0.13		0.49
270	18×20	1850	0.14		0.52
330	16×31.5	2400	0.10		0.38
390	16×35.5	2600	0.085		0.32
390	18×25	2270	0.10		0.37
470	16×40	2860	0.075		0.29
470	18×31.5	2470	0.08		0.30
560	18×35.5	2860	0.07		0.26
680	18×40	3510	0.06	0.22	

- : 副記号 EFUとなります。
- : OPTION has EFU

ZLQ series

105°C 3000~6000時間品 超小形化 低インピーダンス品
105°C 3000~6000 hours, UltraMiniaturized, Low Impedance



◆規格表/SPECIFICATIONS

項目 Item	特性 Characteristics							
カテゴリ温度範囲 Category Temperature Range	-40~+105°C							
定格電圧範囲 Rated Voltage Range	6.3~35Vdc							
静電容量許容差 Capacitance Tolerance	±20%(20°C, 120Hz)							
漏れ電流 Leakage Current (MAX)	I=0.03CV又は3µAのいずれか大なる値以下(定格電圧印加2分後) I=0.03CV or 3µA whichever is greater. (After 2 minutes) I=漏れ電流(µA) C=静電容量(µF) V=定格電圧(Vdc) Leakage Current Capacitance Rated Voltage							
損失角の正接(tan δ) Dissipation Factor (MAX)	定格電圧(Vdc) Rated Voltage	6.3	10	16	25	35	(20°C, 120Hz)	
	tan δ	0.22	0.19	0.16	0.14	0.12		
1000µFを越えるものは1000µF増す毎に上表の値に0.02を加えた値とする。 When capacitance is over 1000µF, tan δ shall be added 0.02 to the listed value with increase of every 1000µF.								
耐久性 Endurance	105°C中で右表の時間定格電圧(リップル重畳)印加後、下記項目を満足すること。 After applying rated voltage with rated ripple current for specified time at 105°C, the capacitors shall meet the following requirements.							
	静電容量変化率 Capacitance Change	初期値の±25%以内(6.3Vdc, 10Vdc: ±30%) Within ±25% of the initial value(6.3Vdc, 10Vdc: ±30%)					ケースサイズ Case Size	時間(hrs) Time(hrs)
	損失角の正接 Dissipation Factor	規格値の200%以下 Not more than 200% of the specified value.					φD ≤ 6.3	3000
	漏れ電流 Leakage Current	規格値以下 Not more than the specified value.					φD = 8	4000
φD = 10								5000
φD ≥ 12.5								6000
低温特性 Low Temperature Stability (インピーダンス比) Impedance Ratio (MAX)	定格電圧(Vdc) Rated Voltage	6.3	10	16	25	35	(120Hz)	
	Z(-25°C)/Z(+20°C)	3	2	2	2	2		
	Z(-40°C)/Z(+20°C)	6	4	3	3	3		

◆呼称方法/PART NUMBER

ZLQ M D x L
 定格電圧 シリーズ名 静電容量 静電容量許容差 副記号 リード加工記号 ケースサイズ
 Rated Voltage Series Capacitance Capacitance Tolerance Option Lead Forming Case Size

◆リップル電流補正係数/
MULTIPLIER FOR RIPPLE CURRENT

周波数(Hz) Frequency		120	1k	10k	100k ≤
係数 Coefficient	56~270µF	0.50	0.73	0.92	1.00
	330~680µF	0.55	0.77	0.94	1.00
	820~1800µF	0.60	0.80	0.96	1.00
	2200~12000µF	0.70	0.85	0.98	1.00

◆副記号/OPTION

EFC : PETスリーブ PET Sleeve

◆寸法図/DIMENSIONS

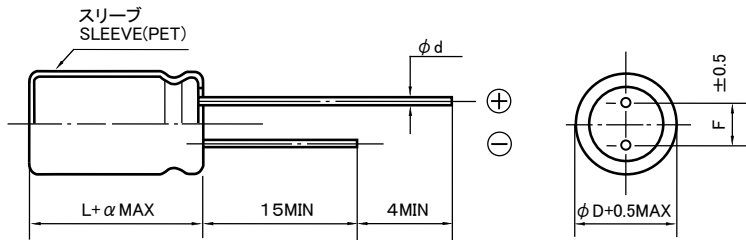

(mm)						
ϕD	5	6.3	8	10	12.5	16
ϕd	0.5		0.6			0.8
F	2.0	2.5	3.5	5.0		7.5
α	L \leq 16 : $\alpha = 1.5$ L \geq 20 : $\alpha = 2.0$					

◆標準品一覧表/STANDARD SIZE

Rated Ripple Current (mA r.m.s./105°C, 100kHz)

定格電圧 Rated Voltage (Vdc)	静電容量 Capacitance (μF)	外形寸法 Size $\phi D \times L$ (mm)	定格リプル電流 Rated Ripple Current	インピーダンス (Ω MAX) Impedance	
				20°C, 100kHz	-10°C, 100kHz
				6.3	270
	680	6.3x11	620	0.092	0.34
	1200	8x11.5	1060	0.049	0.15
	1500	8x16	1390	0.038	0.12
	1800	10x12.5	1470	0.035	0.11
	2200	8x20	1660	0.027	0.081
	2700	10x16	1930	0.025	0.075
	3900	10x20	2130	0.018	0.054
	4700	10x25	2500	0.015	0.045
	5600	12.5x20	2690	0.016	0.041
	8200	12.5x25	3140	0.013	0.033
	8200	12.5x30	3680	0.012	0.030
	10000	16x20	3500	0.014	0.035
	10000	12.5x35	3800	0.010	0.025
	12000	16x25	3880	0.011	0.028
10	220	5x11	400	0.21	0.77
	470	6.3x11	620	0.092	0.34
	820	8x11.5	1060	0.049	0.15
	1200	8x16	1390	0.038	0.12
	1200	10x12.5	1470	0.035	0.11
	1800	8x20	1660	0.027	0.081
	1800	10x16	1930	0.025	0.075
	2700	10x20	2130	0.018	0.054
	3300	10x25	2500	0.015	0.045
	3900	12.5x20	2690	0.016	0.041
	5600	12.5x25	3140	0.013	0.033
	6800	12.5x30	3680	0.012	0.030
	6800	16x20	3500	0.014	0.035
	8200	12.5x35	3800	0.010	0.025
	8200	16x25	3880	0.011	0.028
16	150	5x11	400	0.21	0.77
	330	6.3x11	620	0.092	0.34
	560	8x11.5	1060	0.049	0.15
	820	8x16	1390	0.038	0.12
	820	10x12.5	1470	0.035	0.11
	1200	8x20	1660	0.027	0.081
	1200	10x16	1930	0.025	0.075
	1800	10x20	2130	0.018	0.054
	2200	10x25	2500	0.015	0.045
	2700	12.5x20	2690	0.016	0.041
	3900	12.5x25	3140	0.013	0.033
	3900	12.5x30	3680	0.012	0.030
	4700	16x20	3500	0.014	0.035
	5600	12.5x35	3800	0.010	0.025
	5600	16x25	3880	0.011	0.028

定格電圧 Rated Voltage (Vdc)	静電容量 Capacitance (μF)	外形寸法 Size $\phi D \times L$ (mm)	定格リプル電流 Rated Ripple Current	インピーダンス (Ω MAX) Impedance	
				20°C, 100kHz	-10°C, 100kHz
				25	82
	180	6.3x11	620	0.092	0.34
	330	8x11.5	1060	0.049	0.15
	470	8x16	1390	0.038	0.12
	560	10x12.5	1470	0.035	0.11
	680	8x20	1660	0.027	0.081
	820	10x16	1930	0.025	0.075
	1200	10x20	2130	0.018	0.054
	1500	10x25	2500	0.015	0.045
	1800	12.5x20	2690	0.016	0.041
	2200	12.5x25	3140	0.013	0.033
	2700	12.5x30	3680	0.012	0.030
	2700	16x20	3500	0.014	0.035
	3300	12.5x35	3800	0.010	0.025
	3900	16x25	3880	0.011	0.028
35	56	5x11	400	0.21	0.77
	120	6.3x11	620	0.092	0.34
	220	8x11.5	1060	0.049	0.15
	270	8x16	1390	0.038	0.12
	330	10x12.5	1470	0.035	0.11
	390	8x20	1660	0.027	0.081
	470	10x16	1930	0.025	0.075
	680	10x20	2130	0.018	0.054
	820	10x25	2500	0.015	0.045
	1000	12.5x20	2690	0.016	0.041
	1500	12.5x25	3140	0.013	0.033
	1500	12.5x30	3680	0.012	0.030
	1800	16x20	3500	0.014	0.035
	2200	12.5x35	3800	0.010	0.025
	2200	16x25	3880	0.011	0.028

ZLS series

105°C 6000時間品 小形化 低インピーダンス品
Load Life : 105°C 6000 hours, Miniaturized, Low Impedance



◆規格表/SPECIFICATIONS

項目 Item	特性 Characteristics																
カテゴリ温度範囲 Category Temperature Range	-40~+105°C																
定格電圧範囲 Rated Voltage Range	10~35Vdc																
静電容量許容差 Capacitance Tolerance	±20%(20°C, 120Hz)																
漏れ電流 Leakage Current (MAX)	I=0.01CV以下(定格電圧印加2分後) I=0.01CV MAX. (After 2 minutes) I=漏れ電流(µA) C=静電容量(µF) V=定格電圧(Vdc) Leakage Current Capacitance Rated Voltage																
損失角の正接(tan δ) Dissipation Factor (MAX)	<table border="1"> <tr> <td>定格電圧(Vdc) Rated Voltage</td> <td>10</td> <td>16</td> <td>25</td> <td>35</td> <td rowspan="2">(20°C, 120Hz)</td> </tr> <tr> <td>tan δ</td> <td>0.19</td> <td>0.16</td> <td>0.14</td> <td>0.12</td> </tr> </table> <p>1000µFを越えるものは1000µF増す毎に上表の値に0.02を加えた値とする。 When capacitance is over 1000µF, tan δ shall be added 0.02 to the listed value with increase of every 1000µF.</p>	定格電圧(Vdc) Rated Voltage	10	16	25	35	(20°C, 120Hz)	tan δ	0.19	0.16	0.14	0.12					
定格電圧(Vdc) Rated Voltage	10	16	25	35	(20°C, 120Hz)												
tan δ	0.19	0.16	0.14	0.12													
耐久性 Endurance	<p>105°C中で6000時間定格電圧(リップル重畳)印加後、下記項目を満足すること。 After applying rated voltage with rated ripple current for 6000 hours at 105°C, the capacitors shall meet the following requirements.</p> <table border="1"> <tr> <td>静電容量変化率 Capacitance Change</td> <td>初期値の±25%以内(10V: ±30%) Within ±25% of the initial value.(10V: ±30%)</td> </tr> <tr> <td>損失角の正接 Dissipation Factor</td> <td>規格値の200%以下 Not more than 200% of the specified value.</td> </tr> <tr> <td>漏れ電流 Leakage Current</td> <td>規格値以下 Not more than the specified value.</td> </tr> </table>	静電容量変化率 Capacitance Change	初期値の±25%以内(10V: ±30%) Within ±25% of the initial value.(10V: ±30%)	損失角の正接 Dissipation Factor	規格値の200%以下 Not more than 200% of the specified value.	漏れ電流 Leakage Current	規格値以下 Not more than the specified value.										
静電容量変化率 Capacitance Change	初期値の±25%以内(10V: ±30%) Within ±25% of the initial value.(10V: ±30%)																
損失角の正接 Dissipation Factor	規格値の200%以下 Not more than 200% of the specified value.																
漏れ電流 Leakage Current	規格値以下 Not more than the specified value.																
低温特性 Low Temperature Stability (インピーダンス比) Impedance Ratio (MAX)	<table border="1"> <tr> <td>定格電圧(Vdc) Rated Voltage</td> <td>10</td> <td>16</td> <td>25</td> <td>35</td> <td rowspan="3">(120Hz)</td> </tr> <tr> <td>Z(-25°C)/Z(+20°C)</td> <td>2</td> <td>2</td> <td>2</td> <td>2</td> </tr> <tr> <td>Z(-40°C)/Z(+20°C)</td> <td>3</td> <td>3</td> <td>3</td> <td>3</td> </tr> </table>	定格電圧(Vdc) Rated Voltage	10	16	25	35	(120Hz)	Z(-25°C)/Z(+20°C)	2	2	2	2	Z(-40°C)/Z(+20°C)	3	3	3	3
定格電圧(Vdc) Rated Voltage	10	16	25	35	(120Hz)												
Z(-25°C)/Z(+20°C)	2	2	2	2													
Z(-40°C)/Z(+20°C)	3	3	3	3													

◆呼称方法/PART NUMBER

ZLS M D x L
 定格電圧 シリーズ名 静電容量 静電容量許容差 副記号 リード加工記号 ケースサイズ
 Rated Voltage Series Capacitance Capacitance Tolerance Option Lead Forming Case Size

◆リップル電流補正係数/
MULTIPLIER FOR RIPPLE CURRENT

周波数 (Hz) Frequency	120	1k	10k	100k ≤
220~270µF	0.50	0.73	0.92	1.00
330~680µF	0.55	0.77	0.94	1.00
820~1800µF	0.60	0.80	0.96	1.00
2200~5600µF	0.70	0.85	0.98	1.00

◆副記号/OPTION

EFC : PETスリーブ PET Sleeve

◆寸法図／DIMENSIONS

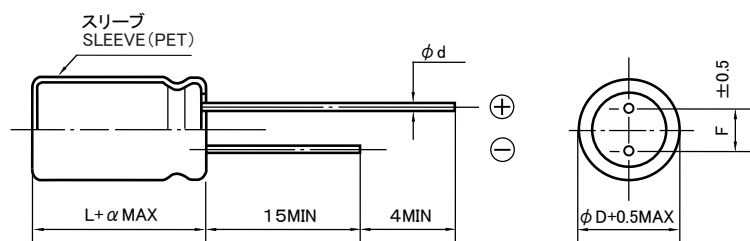

(mm)

ϕD	8	10	12.5
ϕd	0.6		
F	3.5	5.0	
α	$L \leq 16 : \alpha = 1.5$ $L \geq 20 : \alpha = 2.0$		

◆標準品一覧表／STANDARD SIZE

Rated Ripple Current (mA r.m.s./105°C, 100kHz)

定格電圧 Rated Voltage (Vdc)	静電容量 Capacitance (μF)	外形寸法 Size $\phi D \times L$ (mm)	定格リプル電流 Rated ripple current	インピーダンス(Ω MAX) Impedance	
				20°C, 100kHz	-10°C, 100kHz
10	680	8×11.5	900	0.062	0.19
	1000	8×16	1210	0.048	0.15
	1000	10×12.5	1240	0.045	0.14
	1500	8×20	1410	0.033	0.11
	1500	10×16	1650	0.032	0.10
	1800	10×20	1960	0.020	0.060
	2200	10×23	2250	0.018	0.054
	3300	12.5×20	2480	0.017	0.043
	3900	12.5×25	2900	0.015	0.038
	4700	12.5×30	3450	0.013	0.033
16	5600	12.5×35	3570	0.012	0.031
	470	8×11.5	900	0.062	0.19
	680	8×16	1210	0.048	0.15
	680	10×12.5	1240	0.045	0.14
	1000	8×20	1410	0.033	0.11
	1000	10×16	1650	0.032	0.10
	1500	10×20	1960	0.020	0.060
	1800	10×23	2250	0.018	0.054
	2200	10×25	2500	0.017	0.051
	2200	12.5×20	2480	0.017	0.043
	2700	12.5×25	2900	0.015	0.038
	3300	12.5×30	3450	0.013	0.033
	3900	12.5×35	3570	0.012	0.031
25	330	8×11.5	900	0.062	0.19
	390	8×16	1210	0.048	0.15
	470	10×12.5	1240	0.045	0.14
	560	8×20	1410	0.033	0.11
	680	10×16	1650	0.032	0.10
	820	10×20	1960	0.020	0.060
	1000	10×20	1960	0.020	0.060
	1000	10×23	2250	0.018	0.054
	1500	12.5×20	2480	0.017	0.043
	1800	12.5×25	2900	0.015	0.038
	2200	12.5×30	3450	0.013	0.033
	2700	12.5×35	3570	0.012	0.031
35	220	8×11.5	900	0.062	0.19
	270	8×16	1210	0.048	0.15
	330	10×12.5	1240	0.045	0.14
	390	8×20	1410	0.033	0.11
	470	10×16	1650	0.032	0.100
	560	10×20	1960	0.020	0.060
	680	10×23	2250	0.018	0.054
	1000	12.5×20	2480	0.017	0.043
	1200	12.5×25	2900	0.015	0.038
	1500	12.5×30	3450	0.013	0.033
	1800	12.5×35	3570	0.012	0.031

BXW series

105°C長寿命(10000~12000時間)小形化品 -40°C対応
105°C 10000~12000 hours, Miniaturized, -40°C~+105°C

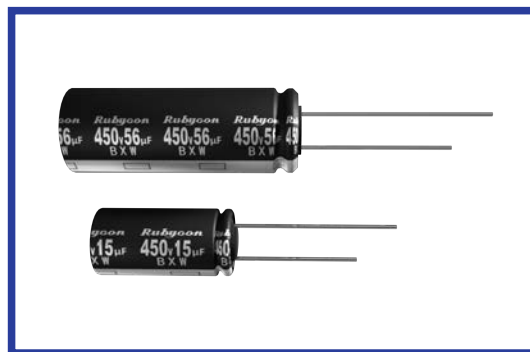

◆規格表/SPECIFICATIONS

項目 Item	特性 Characteristics													
カテゴリ温度範囲 Category Temperature Range	-40~+105°C													
定格電圧範囲 Rated Voltage Range	160~450Vdc													
静電容量許容差 Capacitance Tolerance	±20%(20°C, 120Hz)													
漏れ電流 Leakage Current (MAX)	$I=3\sqrt{CV}$ (定格電圧印加5分後) $I=3\sqrt{CV}$ (After 5 minutes application of rated voltage) I=漏れ電流(μA) C=静電容量(μF) V=定格電圧(Vdc) Leakage Current Capacitance Rated Voltage													
損失角の正接(tan δ) Dissipation Factor (MAX)	<table border="1"> <tr> <td>定格電圧 (Vdc) Rated Voltage</td> <td>160~400</td> <td>420, 450</td> <td rowspan="2">(20°C, 120Hz)</td> </tr> <tr> <td>tan δ</td> <td>0.20</td> <td>0.25</td> </tr> </table>	定格電圧 (Vdc) Rated Voltage	160~400	420, 450	(20°C, 120Hz)	tan δ	0.20	0.25						
定格電圧 (Vdc) Rated Voltage	160~400	420, 450	(20°C, 120Hz)											
tan δ	0.20	0.25												
耐久性 Endurance	<p>105°C中で右表の時間定格電圧(リップル重畳)印加後、下記項目を満足すること。 After applying rated voltage with rated ripple current for specified time at 105°C, the capacitors shall meet the following requirements.</p> <table border="1"> <tr> <td>静電容量変化率 Capacitance Change</td> <td>初期値の ±20% 以内 Within ±20% of the initial value.</td> <td>ケースサイズ Case Size</td> <td>時間(hrs) Time(hrs)</td> </tr> <tr> <td>損失角の正接 Dissipation Factor</td> <td>規格値の 200% 以下 Not more than 200% of the specified value.</td> <td>L ≤ 20</td> <td>10000</td> </tr> <tr> <td>漏れ電流 Leakage Current</td> <td>規格値以下 Not more than the specified value.</td> <td>L ≥ 25</td> <td>12000</td> </tr> </table>	静電容量変化率 Capacitance Change	初期値の ±20% 以内 Within ±20% of the initial value.	ケースサイズ Case Size	時間(hrs) Time(hrs)	損失角の正接 Dissipation Factor	規格値の 200% 以下 Not more than 200% of the specified value.	L ≤ 20	10000	漏れ電流 Leakage Current	規格値以下 Not more than the specified value.	L ≥ 25	12000	
静電容量変化率 Capacitance Change	初期値の ±20% 以内 Within ±20% of the initial value.	ケースサイズ Case Size	時間(hrs) Time(hrs)											
損失角の正接 Dissipation Factor	規格値の 200% 以下 Not more than 200% of the specified value.	L ≤ 20	10000											
漏れ電流 Leakage Current	規格値以下 Not more than the specified value.	L ≥ 25	12000											
低温特性 Low Temperature Stability (インピーダンス比) Impedance Ratio (MAX)	<table border="1"> <tr> <td>定格電圧 (Vdc) Rated Voltage</td> <td>160~250</td> <td>350, 400</td> <td>420, 450</td> <td rowspan="3">(120Hz)</td> </tr> <tr> <td>Z(-25°C)/Z(+20°C)</td> <td>3</td> <td>5</td> <td>6</td> </tr> <tr> <td>Z(-40°C)/Z(+20°C)</td> <td>6</td> <td>6</td> <td>10</td> </tr> </table>	定格電圧 (Vdc) Rated Voltage	160~250	350, 400	420, 450	(120Hz)	Z(-25°C)/Z(+20°C)	3	5	6	Z(-40°C)/Z(+20°C)	6	6	10
定格電圧 (Vdc) Rated Voltage	160~250	350, 400	420, 450	(120Hz)										
Z(-25°C)/Z(+20°C)	3	5	6											
Z(-40°C)/Z(+20°C)	6	6	10											

◆呼称方法/PART NUMBER

BXW M D x L
 定格電圧 シリーズ名 静電容量 静電容量許容差 副記号 リード加工記号 ケースサイズ
 Rated Voltage Series Capacitance Capacitance Tolerance Option Lead Forming Case Size

◆リップル電流補正係数/
MULTIPLIER FOR RIPPLE CURRENT

周波数 (Hz) Frequency	60(50)	120	500	1k	10k	100k ≤
10~82 μF	0.80	1.00	1.30	1.50	2.10	2.50
100~220 μF	0.80	1.00	1.30	1.50	2.00	2.25
270~820 μF	0.80	1.00	1.30	1.50	1.90	2.00

◆副記号/OPTION

EFR : PETスリーブ PET Sleeve

◆寸法図／DIMENSIONS

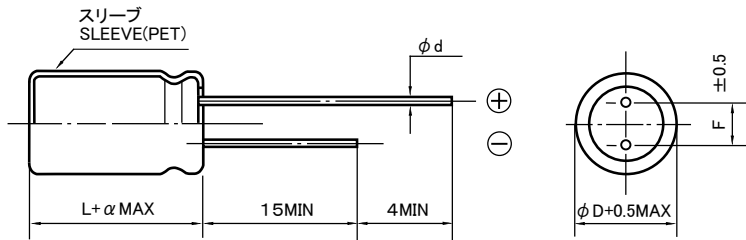

	(mm)				
φD	10	12.5	14.5	16	18
φd	0.6		0.8		
F	5.0		7.5		
α	2.0				

◆標準品一覧表／STANDARD SIZE

Rated Ripple Current (A r.m.s./105°C)

定格電圧 Rated Voltage (Vdc)	静電容量 Capacitance (μF)	外形寸法 Size φD × L (mm)	定格リプル電流 Rated Ripple Current	
			120Hz	100kHz
160	47	10×16	0.260	0.650
	68	10×20	0.320	0.800
	82	16×16	0.540	1.350
	100	10×25	0.530	1.193
	100	12.5×20	0.600	1.350
	100	18×16	0.690	1.553
	120	10×30	0.620	1.395
	150	10×35	0.700	1.575
	150	12.5×25	0.730	1.643
	150	14.5×20	0.800	1.800
	180	10×40	0.800	1.800
	180	12.5×30	0.870	1.958
	180	16×20	0.800	1.800
	220	10×50	1.000	2.250
	220	12.5×35	1.000	2.250
	220	14.5×25	0.890	2.003
	220	18×20	0.990	2.228
	270	12.5×40	1.120	2.240
	270	14.5×30	1.100	2.200
	270	16×25	1.000	2.000
	330	12.5×45	1.240	2.480
	330	14.5×35	1.220	2.440
	330	16×30	1.200	2.400
	330	18×25	1.180	2.360
390	14.5×40	1.380	2.760	
390	16×35	1.380	2.760	
470	14.5×45	1.520	3.040	
470	16×40	1.550	3.100	
470	18×30	1.550	3.100	
560	16×45	1.760	3.520	
560	18×35	1.740	3.480	
680	18×40	2.000	4.000	
820	18×50	2.230	4.460	
200	33	10×16	0.260	0.650
	47	10×20	0.320	0.800
	56	16×16	0.540	1.350
	68	10×25	0.430	1.075
	68	12.5×20	0.540	1.350
	82	10×30	0.500	1.250
	82	18×16	0.620	1.550
	100	10×35	0.640	1.440
	100	14.5×20	0.580	1.305
	120	10×40	0.740	1.665
	120	12.5×25	0.650	1.463
	120	16×20	0.800	1.800
	150	10×45	0.780	1.755
	150	12.5×30	0.800	1.800
	150	14.5×25	0.790	1.778
	180	12.5×35	0.920	2.070
	180	14.5×30	0.950	2.138

定格電圧 Rated Voltage (Vdc)	静電容量 Capacitance (μF)	外形寸法 Size φD × L (mm)	定格リプル電流 Rated Ripple Current		
			120Hz	100kHz	
200	180	16×25	0.900	2.025	
	180	18×20	1.000	2.250	
	220	12.5×40	1.050	2.363	
	220	14.5×35	1.090	2.453	
	220	16×30	1.080	2.430	
	270	12.5×50	1.260	2.520	
	270	14.5×40	1.260	2.520	
	270	16×30	1.180	2.360	
	270	18×25	1.100	2.200	
	330	14.5×45	1.370	2.740	
	330	16×40	1.430	2.860	
	330	18×30	1.300	2.600	
	390	14.5×50	1.480	2.960	
	390	16×45	1.550	3.100	
	390	18×35	1.430	2.860	
	470	16×50	1.680	3.360	
	470	18×40	1.620	3.240	
	560	18×45	1.770	3.540	
	220	33	10×16	0.240	0.600
		47	10×20	0.300	0.750
		56	10×25	0.400	1.000
		68	12.5×20	0.480	1.200
		82	10×30	0.500	1.250
		100	10×35	0.640	1.440
100		12.5×25	0.620	1.395	
100		14.5×20	0.600	1.350	
120		10×45	0.750	1.688	
120		12.5×30	0.740	1.665	
120		14.5×25	0.750	1.688	
120		16×20	0.680	1.530	
150		12.5×35	0.880	1.980	
150		18×20	0.830	1.868	
180		12.5×40	1.020	2.295	
180		14.5×30	0.910	2.048	
180		16×25	0.900	2.025	
220		12.5×45	1.050	2.363	
220		14.5×35	1.040	2.340	
220		16×30	1.030	2.318	
220		18×25	0.990	2.228	
270		14.5×45	1.300	2.600	
270		16×35	1.190	2.380	
270		18×30	1.170	2.340	
330		14.5×50	1.410	2.820	
330		16×40	1.360	2.720	
330		18×35	1.350	2.700	
390		16×45	1.480	2.960	
390	18×40	1.550	3.100		
470	18×45	1.690	3.380		
560	18×50	1.800	3.600		

◆標準品一覧表 / STANDARD SIZE

定格電圧 Rated Voltage (Vdc)	静電容量 Capacitance (μ F)	外形寸法 Size ϕ D × L (mm)	定格リプル電流 Rated Ripple Current	
			120Hz	100kHz
250	27	10×16	0.260	0.650
	39	10×20	0.320	0.800
	47	10×25	0.390	0.975
	47	16×16	0.540	1.350
	56	12.5×20	0.540	1.350
	56	18×16	0.620	1.550
	68	10×30	0.500	1.250
	82	10×35	0.570	1.425
	82	12.5×25	0.570	1.425
	82	14.5×20	0.500	1.250
	100	10×45	0.720	1.620
	100	12.5×30	0.690	1.553
	100	16×20	0.800	1.800
	120	10×50	0.780	1.755
	120	12.5×35	0.790	1.778
	120	14.5×25	0.750	1.688
	120	18×20	1.000	2.250
	150	12.5×40	0.920	2.070
	150	14.5×30	0.830	1.868
	150	16×25	0.840	1.890
	180	12.5×45	0.970	2.183
	180	14.5×35	0.960	2.160
	180	16×30	0.950	2.138
	180	18×25	0.920	2.070
	220	14.5×40	1.110	2.498
	220	16×35	1.100	2.475
	220	18×30	1.100	2.475
	270	14.5×50	1.300	2.600
	270	16×40	1.270	2.540
	270	18×35	1.260	2.520
330	16×50	1.480	2.960	
330	18×40	1.450	2.900	
390	18×45	1.590	3.180	
470	18×50	1.830	3.660	
350	18	10×16	0.160	0.400
	22	10×20	0.200	0.500
	27	16×16	0.310	0.775
	33	10×25	0.330	0.825
	33	12.5×20	0.340	0.850
	33	18×16	0.380	0.950
	39	10×30	0.390	0.975
	47	10×35	0.450	1.125
	47	12.5×25	0.450	1.125
	47	14.5×20	0.420	1.050
	56	10×40	0.520	1.300
	56	12.5×30	0.550	1.375
	56	16×20	0.480	1.200
	68	10×50	0.600	1.500
	68	12.5×35	0.610	1.525
	68	14.5×25	0.560	1.400
	82	12.5×40	0.710	1.775
	82	14.5×30	0.670	1.675
	82	16×25	0.650	1.625
	82	18×20	0.520	1.300
	100	12.5×45	0.790	1.778
	100	14.5×35	0.780	1.755
	100	16×30	0.770	1.733
	100	18×25	0.760	1.710
	120	12.5×50	0.850	1.913
	120	14.5×40	0.900	2.025

Rated Ripple Current (A r.m.s./105°C)

定格電圧 Rated Voltage (Vdc)	静電容量 Capacitance (μ F)	外形寸法 Size ϕ D × L (mm)	定格リプル電流 Rated Ripple Current		
			120Hz	100kHz	
350	120	16×35	0.890	2.003	
	150	14.5×45	0.970	2.183	
	150	16×40	1.000	2.250	
	150	18×30	0.900	2.025	
	180	16×45	1.120	2.520	
	180	18×35	1.040	2.340	
	220	18×40	1.200	2.700	
	270	18×50	1.400	2.800	
	400	12	10×16	0.160	0.400
		18	10×20	0.220	0.550
		18	16×16	0.230	0.575
		22	10×25	0.240	0.600
27		10×25	0.290	0.725	
27		12.5×20	0.340	0.850	
27		18×16	0.380	0.950	
33		10×30	0.340	0.850	
39		10×35	0.390	0.975	
39		12.5×25	0.390	0.975	
39		14.5×20	0.360	0.900	
47		10×40	0.440	1.100	
47		12.5×30	0.455	1.138	
47		16×20	0.470	1.175	
56		10×45	0.500	1.250	
56		12.5×30	0.495	1.238	
56		12.5×35	0.525	1.313	
56		14.5×25	0.495	1.238	
56		16×20	0.480	1.200	
56		18×20	0.520	1.300	
68		12.5×35	0.570	1.425	
68		12.5×40	0.600	1.500	
68		14.5×30	0.585	1.463	
68		16×25	0.570	1.425	
68		18×20	0.530	1.325	
82		12.5×40	0.650	1.625	
82		12.5×45	0.680	1.700	
82		14.5×35	0.670	1.675	
82		16×30	0.670	1.675	
82		18×25	0.640	1.600	
100		12.5×50	0.760	1.710	
100		14.5×40	0.760	1.710	
100		14.5×45	0.785	1.766	
100		16×30	0.710	1.598	
100		16×35	0.760	1.710	
100		18×25	0.710	1.598	
120	14.5×45	0.840	1.890		
120	14.5×50	0.875	1.969		
120	16×35	0.810	1.823		
120	16×40	0.860	1.935		
120	18×30	0.840	1.890		
120	18×35	0.870	1.958		
150	16×45	0.950	2.138		
150	16×50	0.995	2.239		
150	18×35	0.920	2.070		
150	18×40	0.985	2.216		
180	16×50	1.070	2.408		
180	18×40	1.040	2.340		
180	18×45	1.095	2.464		
220	18×50	1.220	2.745		

◆標準品一覧表 / STANDARD SIZE

Rated Ripple Current (A r.m.s./105°C)

定格電圧 Rated Voltage (Vdc)	静電容量 Capacitance (μ F)	外形寸法 Size ϕ D \times L (mm)	定格リプル電流 Rated Ripple Current	
			120Hz	100kHz
420	15	10 \times 20	0.190	0.475
	18	10 \times 25	0.230	0.575
	22	10 \times 25	0.250	0.625
	27	10 \times 30	0.290	0.725
	27	12.5 \times 20	0.300	0.750
	27	12.5 \times 25	0.340	0.850
	33	10 \times 35	0.340	0.850
	33	12.5 \times 25	0.350	0.875
	33	12.5 \times 30	0.400	1.000
	33	14.5 \times 20	0.350	0.875
	39	10 \times 40	0.390	0.975
	39	14.5 \times 25	0.435	1.088
	39	16 \times 20	0.400	1.000
	47	10 \times 45	0.440	1.100
	47	12.5 \times 30	0.440	1.100
	47	12.5 \times 35	0.505	1.263
	47	14.5 \times 25	0.450	1.125
	47	16 \times 25	0.440	1.100
	56	12.5 \times 35	0.510	1.275
	56	12.5 \times 40	0.570	1.425
	56	14.5 \times 30	0.560	1.400
	56	16 \times 25	0.510	1.275
	56	18 \times 20	0.480	1.200
	68	12.5 \times 45	0.600	1.500
	68	12.5 \times 50	0.670	1.675
	68	14.5 \times 35	0.640	1.600
	68	16 \times 30	0.560	1.400
	68	18 \times 25	0.615	1.538
	82	12.5 \times 50	0.690	1.725
	82	14.5 \times 40	0.680	1.700
	82	14.5 \times 45	0.750	1.875
	82	16 \times 30	0.640	1.600
	82	16 \times 35	0.690	1.725
	82	18 \times 25	0.640	1.600
	82	18 \times 30	0.730	1.825
	100	14.5 \times 45	0.790	1.778
	100	14.5 \times 50	0.845	1.901
	100	16 \times 35	0.730	1.643
	100	16 \times 40	0.800	1.800
	100	18 \times 30	0.780	1.755
	100	18 \times 35	0.835	1.879
	120	16 \times 40	0.840	1.890
120	16 \times 45	0.920	2.070	
120	18 \times 35	0.850	1.913	
120	18 \times 40	0.930	2.093	
150	16 \times 50	0.940	2.115	
150	18 \times 40	1.000	2.250	
150	18 \times 45	1.060	2.385	
180	18 \times 45	1.100	2.475	
450	10	10 \times 16	0.130	0.325
	15	10 \times 20	0.190	0.475
	15	16 \times 16	0.210	0.525
	18	10 \times 25	0.230	0.575
	22	10 \times 30	0.270	0.675
	22	12.5 \times 20	0.280	0.700
	22	18 \times 16	0.340	0.850
	27	10 \times 35	0.320	0.800
	27	12.5 \times 25	0.340	0.850
	27	14.5 \times 20	0.335	0.838
33	10 \times 40	0.360	0.900	

定格電圧 Rated Voltage (Vdc)	静電容量 Capacitance (μ F)	外形寸法 Size ϕ D \times L (mm)	定格リプル電流 Rated Ripple Current	
			120Hz	100kHz
450	33	12.5 \times 25	0.360	0.900
	33	12.5 \times 30	0.400	1.000
	33	14.5 \times 25	0.400	1.000
	39	10 \times 45	0.410	1.025
	39	12.5 \times 30	0.430	1.075
	39	12.5 \times 35	0.460	1.150
	39	14.5 \times 25	0.430	1.075
	39	16 \times 20	0.400	1.000
	47	12.5 \times 35	0.480	1.200
	47	12.5 \times 40	0.525	1.313
	47	14.5 \times 30	0.515	1.288
	47	16 \times 25	0.500	1.250
	47	18 \times 20	0.460	1.150
	56	12.5 \times 40	0.540	1.350
	56	12.5 \times 45	0.590	1.475
	56	14.5 \times 30	0.540	1.350
	56	14.5 \times 35	0.580	1.450
	56	16 \times 25	0.530	1.325
	56	16 \times 30	0.585	1.463
	56	18 \times 25	0.560	1.400
	68	12.5 \times 45	0.610	1.525
	68	12.5 \times 50	0.670	1.675
	68	14.5 \times 35	0.620	1.550
	68	14.5 \times 40	0.660	1.650
	68	16 \times 30	0.610	1.525
	68	16 \times 35	0.660	1.650
	68	18 \times 25	0.610	1.525
	82	14.5 \times 40	0.670	1.675
	82	14.5 \times 45	0.740	1.850
	82	16 \times 35	0.690	1.725
	82	16 \times 40	0.750	1.875
	82	18 \times 30	0.730	1.825
	100	14.5 \times 50	0.810	1.823
	100	16 \times 40	0.770	1.733
	100	16 \times 45	0.840	1.890
	100	18 \times 30	0.750	1.688
	100	18 \times 35	0.835	1.879
	120	16 \times 45	0.880	1.980
	120	18 \times 35	0.860	1.935
	120	18 \times 40	0.930	2.093
	150	18 \times 45	1.000	2.250
	150	18 \times 50	1.060	2.385
180	18 \times 50	1.100	2.475	

BHW series

車載専用 Automotive Only

105°C 10000~12000時間品 -40°C対応
105°C 10000~12000 hours, Temp.Range : -40°C

•車載充電器向けに最適
Suitable for On Board Charger.

AEC-Q200

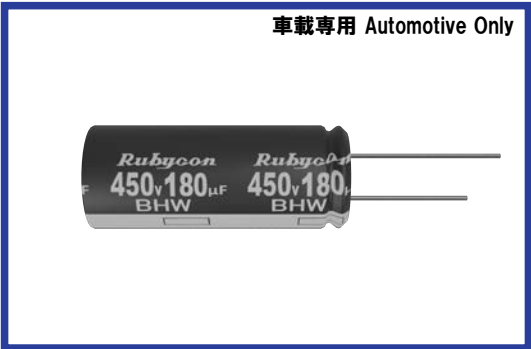

◆規格表 / SPECIFICATIONS

項目 Item	特性 Characteristics														
カテゴリ温度範囲 Category Temperature Range	-40~+105°C														
定格電圧範囲 Rated Voltage Range	400~450Vdc														
静電容量許容差 Capacitance Tolerance	±20%(20°C, 120Hz)														
漏れ電流 Leakage Current (MAX)	$I=3\sqrt{CV}$ (定格電圧印加5分後) $I=3\sqrt{CV}$ (After 5 minutes application of rated voltage) I=漏れ電流(μA) C=静電容量(μF) V=定格電圧(Vdc) Leakage Current Capacitance Rated Voltage														
損失角の正接(tan δ) Dissipation Factor (MAX)	<table border="1"> <tr> <td>定格電圧 (Vdc) Rated Voltage</td> <td>400</td> <td>420, 450</td> </tr> <tr> <td>tan δ</td> <td>0.20</td> <td>0.25</td> </tr> </table> (20°C, 120Hz)	定格電圧 (Vdc) Rated Voltage	400	420, 450	tan δ	0.20	0.25								
定格電圧 (Vdc) Rated Voltage	400	420, 450													
tan δ	0.20	0.25													
耐久性 Endurance	105°C中で右表の時間定格電圧(リップル重畳)印加後、下記項目を満足すること。 After applying rated voltage with rated ripple current for specified time at 105°C, the capacitors shall meet the following requirements.	<table border="1"> <tr> <td>静電容量変化率 Capacitance Change</td> <td>初期値の ±20% 以内 Within ±20% of the initial value.</td> </tr> <tr> <td>損失角の正接 Dissipation Factor</td> <td>規格値の 200% 以下 Not more than 200% of the specified value.</td> </tr> <tr> <td>漏れ電流 Leakage Current</td> <td>規格値以下 Not more than the specified value.</td> </tr> </table>	静電容量変化率 Capacitance Change	初期値の ±20% 以内 Within ±20% of the initial value.	損失角の正接 Dissipation Factor	規格値の 200% 以下 Not more than 200% of the specified value.	漏れ電流 Leakage Current	規格値以下 Not more than the specified value.	<table border="1"> <tr> <td>ケースサイズ Case Size</td> <td>時間(hrs) Time(hrs)</td> </tr> <tr> <td>L ≤ 20</td> <td>10000</td> </tr> <tr> <td>L ≥ 25</td> <td>12000</td> </tr> </table>	ケースサイズ Case Size	時間(hrs) Time(hrs)	L ≤ 20	10000	L ≥ 25	12000
静電容量変化率 Capacitance Change	初期値の ±20% 以内 Within ±20% of the initial value.														
損失角の正接 Dissipation Factor	規格値の 200% 以下 Not more than 200% of the specified value.														
漏れ電流 Leakage Current	規格値以下 Not more than the specified value.														
ケースサイズ Case Size	時間(hrs) Time(hrs)														
L ≤ 20	10000														
L ≥ 25	12000														
低温特性 Low Temperature Stability (インピーダンス比) Impedance Ratio (MAX)	<table border="1"> <tr> <td>定格電圧 (Vdc) Rated Voltage</td> <td>400</td> <td>420, 450</td> </tr> <tr> <td>Z(-25°C)/Z(+20°C)</td> <td>5</td> <td>6</td> </tr> <tr> <td>Z(-40°C)/Z(+20°C)</td> <td>6</td> <td>10</td> </tr> </table> (120Hz)	定格電圧 (Vdc) Rated Voltage	400	420, 450	Z(-25°C)/Z(+20°C)	5	6	Z(-40°C)/Z(+20°C)	6	10					
定格電圧 (Vdc) Rated Voltage	400	420, 450													
Z(-25°C)/Z(+20°C)	5	6													
Z(-40°C)/Z(+20°C)	6	10													

◆呼称方法 / PART NUMBER

□□□ BHW □□□□□ M SPA □□ D x L
 定格電圧 シリーズ名 静電容量 静電容量許容差 副記号 リード加工記号 ケースサイズ
 Rated Voltage Series Capacitance Capacitance Tolerance Option Lead Forming Case Size

◆リップル電流補正係数 /
MULTIPLIER FOR RIPPLE CURRENT

周波数 (Hz) Frequency	60(50)	120	500	1k	10k	100k ≤
係数 Coefficient	47~91 μF	0.80	1.00	1.30	1.50	2.00
	100~220 μF	0.80	1.00	1.30	1.50	2.00

◆寸法図／DIMENSIONS

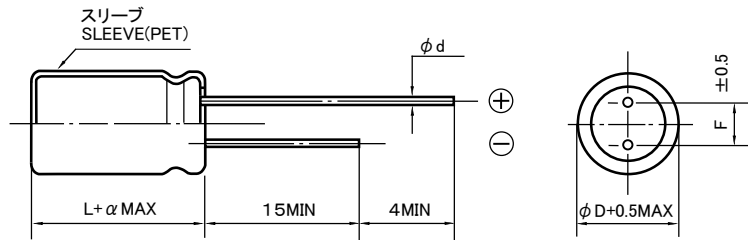

(mm)

φ D	16	18
φ d	0.8	
F	7.5	
α	2.0	

◆標準品一覧表／STANDARD SIZE

定格電圧 Rated Voltage (Vdc)	静電容量 Capacitance (μF)	外形寸法 Size φ D × L (mm)	定格リップル 電流 Rated Ripple Current
400	56	16×20	0.50
	68	18×20	0.57
	75	16×25	0.62
	100	16×30	0.75
	100	18×25	0.73
	120	16×35	0.86
	130	16×40	0.93
	130	18×30	0.87
	150	16×45	1.03
	160	18×35	1.00
	180	18×40	1.11
	190	18×45	1.18
420	220	18×50	1.31
	51	16×20	0.47
	68	16×25	0.58
	68	18×20	0.55
	91	16×30	0.70
	91	18×25	0.69
	110	16×35	0.80
	120	18×30	0.82
	130	16×40	0.91
	150	18×35	0.95
	150	16×45	1.01
	160	18×40	1.03
180	18×45	1.13	
190	18×50	1.20	

Rated Ripple Current (A r.m.s./105°C, 120Hz)

定格電圧 Rated Voltage (Vdc)	静電容量 Capacitance (μF)	外形寸法 Size φ D × L (mm)	定格リップル 電流 Rated Ripple Current
450	47	16×20	0.45
	62	16×25	0.56
	62	18×20	0.53
	82	16×30	0.67
	82	18×25	0.66
	100	16×35	0.78
	110	18×30	0.79
	120	16×40	0.87
	130	18×35	0.90
	130	16×45	0.95
	160	18×40	1.02
	180	18×45	1.12
	190	18×50	1.20

CXW series

105°C 5000時間 超小形化品 -40°C対応
105°C 5000 hours, Ultra Miniaturized, -40°C~+105°C



◆規格表/SPECIFICATIONS

項目 Item	特性 Characteristics								
カテゴリ温度範囲 Category Temperature Range	-40~+105°C								
定格電圧範囲 Rated Voltage Range	180~450Vdc								
静電容量許容差 Capacitance Tolerance	±20%(20°C, 120Hz)								
漏れ電流 Leakage Current (MAX)	$I=3\sqrt{CV}$ (定格電圧印加5分後) $I=3\sqrt{CV}$ (After 5 minutes application of rated voltage) I =漏れ電流(μA) C =静電容量(μF) V =定格電圧(Vdc) Leakage Current Capacitance Rated Voltage								
損失角の正接(tan δ) Dissipation Factor (MAX)	(20°C, 120Hz) <table border="1"> <tr> <td>定格電圧 (Vdc) Rated Voltage</td> <td>180~ 450</td> </tr> <tr> <td>tan δ</td> <td>0.20</td> </tr> </table>	定格電圧 (Vdc) Rated Voltage	180~ 450	tan δ	0.20				
定格電圧 (Vdc) Rated Voltage	180~ 450								
tan δ	0.20								
耐久性 Endurance	105°C中で5000時間定格電圧(リップル重畳)印加後、下記項目を満足すること。 After applying rated voltage with rated ripple current for 5000 hours at 105°C, the capacitors shall meet the following requirements. <table border="1"> <tr> <td>静電容量変化率 Capacitance Change</td> <td>初期値の ±20% 以内 Within ±20% of the initial value.</td> </tr> <tr> <td>損失角の正接 Dissipation Factor</td> <td>規格値の 200% 以下 Not more than 200% of the specified value.</td> </tr> <tr> <td>漏れ電流 Leakage Current</td> <td>規格値以下 Not more than the specified value.</td> </tr> </table>	静電容量変化率 Capacitance Change	初期値の ±20% 以内 Within ±20% of the initial value.	損失角の正接 Dissipation Factor	規格値の 200% 以下 Not more than 200% of the specified value.	漏れ電流 Leakage Current	規格値以下 Not more than the specified value.		
静電容量変化率 Capacitance Change	初期値の ±20% 以内 Within ±20% of the initial value.								
損失角の正接 Dissipation Factor	規格値の 200% 以下 Not more than 200% of the specified value.								
漏れ電流 Leakage Current	規格値以下 Not more than the specified value.								
低温特性 Low Temperature Stability (インピーダンス比) Impedance Ratio (MAX)	(120Hz) <table border="1"> <tr> <td>定格電圧 (Vdc) Rated Voltage</td> <td>180~ 250</td> <td>350, 400</td> <td>420, 450</td> </tr> <tr> <td>Z(-25°C)/Z(+20°C)</td> <td>3</td> <td>5</td> <td>6</td> </tr> </table>	定格電圧 (Vdc) Rated Voltage	180~ 250	350, 400	420, 450	Z(-25°C)/Z(+20°C)	3	5	6
定格電圧 (Vdc) Rated Voltage	180~ 250	350, 400	420, 450						
Z(-25°C)/Z(+20°C)	3	5	6						

◆呼称方法/PART NUMBER

□□□	CXW	□□□□□	M	□□□	□□	D x L
定格電圧 Rated Voltage	シリーズ名 Series	静電容量 Capacitance	静電容量許容差 Capacitance Tolerance	副記号 Option	リード加工記号 Lead Forming	ケースサイズ Case Size

◆リップル電流補正係数/
MULTIPLIER FOR RIPPLE CURRENT

周波数 (Hz) Frequency	60(50)	120	500	1k	10k ≤
係数 Coefficient	180~350v 0.65	1.00	1.25	1.40	1.50
	400~450v 0.80	1.00	1.25	1.40	1.50

◆副記号/OPTION

EFR: PETスリーブ PET Sleeve

◆寸法図／DIMENSIONS

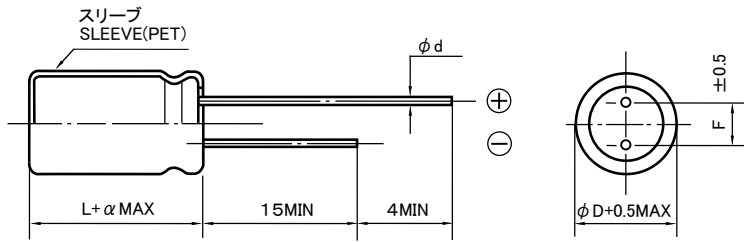

(mm)

φ D	8	10	12.5	14.5	16	18
φ d	0.6			0.8		
F	3.5	5.0		7.5		
α	2.0					

◆標準品一覧表／STANDARD SIZE

Rated Ripple Current (A r.m.s./105°C, 120Hz)

定格電圧 Rated Voltage (Vdc)	静電容量 Capacitance (μ F)	外形寸法 Size φ D × L (mm)	定格リプル 電流 Rated Ripple Current
180	120	10×40	0.53
	150	10×45	0.61
	180	10×50	0.69
	220	12.5×40	0.80
	220	14.5×31.5	0.80
	270	12.5×45	0.91
	270	14.5×35	0.90
	270	16×31.5	0.92
	330	14.5×45	1.09
	330	16×35	1.04
	330	18×31.5	1.03
	390	16×40	1.17
	390	18×35	1.14
	470	16×45	1.31
	470	18×40	1.29
	560	18×45	1.44
680	18×50	1.59	
200	120	10×40	0.54
	150	10×45	0.62
	180	12.5×40	0.73
	220	12.5×45	0.84
	220	14.5×35	0.83
	220	16×31.5	0.85
	270	12.5×50	0.94
	270	14.5×40	0.96
	330	14.5×45	1.08
	330	16×40	1.10
	330	18×31.5	1.02
	390	16×45	1.23
	390	18×35	1.13
	470	16×50	1.37
	470	18×40	1.29
	560	18×45	1.44

定格電圧 Rated Voltage (Vdc)	静電容量 Capacitance (μ F)	外形寸法 Size φ D × L (mm)	定格リプル 電流 Rated Ripple Current
250	82	10×40	0.45
	100	10×45	0.52
	120	10×50	0.59
	150	12.5×40	0.65
	150	14.5×31.5	0.68
	180	12.5×45	0.77
	180	14.5×35	0.77
	180	16×31.5	0.79
	220	14.5×40	0.88
	220	16×35	0.89
	220	18×31.5	0.88
	270	16×40	1.01
	270	18×35	0.99
	330	16×45	1.15
	330	18×40	1.13
	390	18×45	1.27
470	18×50	1.41	
350	56	10×40	0.37
	68	10×45	0.43
	100	12.5×40	0.56
	100	14.5×31.5	0.56
	120	12.5×50	0.66
	120	14.5×35	0.63
	120	16×31.5	0.65
	150	14.5×45	0.76
	150	16×35	0.74
	150	18×31.5	0.74
	180	16×40	0.84
	180	18×35	0.83
	220	16×50	0.99
	220	18×40	0.93
	270	18×45	1.03

◆標準品一覧表／STANDARD SIZE

Rated Ripple Current (A r.m.s./105°C, 120Hz)

定格電圧 Rated Voltage (Vdc)	静電容量 Capacitance (μ F)	外形寸法 Size ϕ D \times L (mm)	定格リップル 電流 Rated Ripple Current
400	15	8x25	0.16
	18	8x30	0.19
	22	8x35	0.22
	27	8x40	0.25
	33	8x45	0.29
	39	10x40	0.37
	47	10x45	0.42
	56	10x50	0.47
	68	12.5x40	0.54
	82	12.5x45	0.61
	82	14.5x31.5	0.57
	100	12.5x50	0.68
	100	14.5x40	0.69
	100	16x31.5	0.71
	120	14.5x45	0.79
	120	16x35	0.80
	150	16x40	0.92
	150	18x31.5	0.89
	150	18x40	1.05
	180	16x50	1.08
180	18x40	1.06	
220	18x45	1.20	
420	12	8x25	0.10
	15	8x30	0.12
	18	8x35	0.16
	22	8x40	0.19
	39	10x40	0.36
	47	10x50	0.43
	56	12.5x40	0.48
	68	12.5x40	0.52
	68	14.5x31.5	0.52
	82	12.5x45	0.59
	82	14.5x35	0.59
	100	14.5x40	0.67
	100	16x31.5	0.69
	120	14.5x45	0.75
	120	16x35	0.78
	120	18x31.5	0.80
	150	16x45	0.94
	150	18x35	0.92
	180	16x50	1.05
	180	18x40	1.04
220	18x50	1.22	

定格電圧 Rated Voltage (Vdc)	静電容量 Capacitance (μ F)	外形寸法 Size ϕ D \times L (mm)	定格リップル 電流 Rated Ripple Current
450	10	8x25	0.12
	12	8x30	0.14
	15	8x35	0.16
	18	8x40	0.18
	22	8x50	0.22
	33	10x40	0.34
	39	10x45	0.38
	47	12.5x40	0.44
	56	12.5x40	0.49
	68	12.5x45	0.55
	68	14.5x31.5	0.52
	82	12.5x50	0.62
	82	14.5x40	0.63
	82	16x31.5	0.64
	100	14.5x45	0.71
	100	16x35	0.73
	120	14.5x50	0.79
	120	16x40	0.82
	120	18x31.5	0.80
	120	18x40	0.85
150	16x50	0.98	
150	18x40	0.97	
180	18x45	1.09	
220	18x50	1.22	

EXW series

125°C 長寿命 (3000~5000 時間) 小形化品
Load Life : 125°C Long Life (3000~5000 hours) , Miniaturized

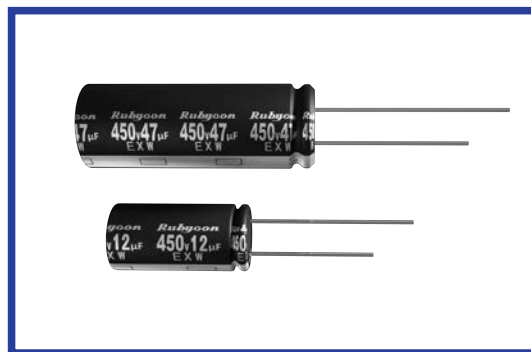

◆規格表 / SPECIFICATIONS

項目 Item	特性 Characteristics													
カテゴリ温度範囲 Category Temperature Range	-40~+125°C	-25~+125°C												
定格電圧範囲 Rated Voltage Range	400~450Vdc	500Vdc												
静電容量許容差 Capacitance Tolerance	±20% (20°C, 120Hz)													
漏れ電流 Leakage Current (MAX)	$I=3\sqrt{CV}$ (定格電圧印加5分後) $I=3\sqrt{CV}$ (After 5 minutes application of rated voltage) I=漏れ電流 (μA) C=静電容量 (μF) V=定格電圧 (Vdc) Leakage Current Capacitance Rated Voltage													
損失角の正接 (tan δ) Dissipation Factor (MAX)	<table border="1"> <tr> <td>定格電圧 (Vdc) Rated Voltage</td> <td>400~450</td> <td>500</td> <td rowspan="2">(20°C, 120Hz)</td> </tr> <tr> <td>tan δ</td> <td>0.25</td> <td>0.28</td> </tr> </table>		定格電圧 (Vdc) Rated Voltage	400~450	500	(20°C, 120Hz)	tan δ	0.25	0.28					
定格電圧 (Vdc) Rated Voltage	400~450	500	(20°C, 120Hz)											
tan δ	0.25	0.28												
耐久性 Endurance	125°C中で右表の時間定格電圧(リップル重畳)印加後、下記項目を満足すること。 After applying rated voltage with rated ripple current for specified time at 125°C, the capacitors shall meet the following requirements.													
	<table border="1"> <tr> <td>静電容量変化率 Capacitance Change</td> <td>初期値の ±30% 以内 Within ±30% of the initial value.</td> </tr> <tr> <td>損失角の正接 Dissipation Factor</td> <td>規格値の 300% 以下 Not more than 300% of the specified value.</td> </tr> <tr> <td>漏れ電流 Leakage Current</td> <td>規格値以下 Not more than the specified value.</td> </tr> </table>	静電容量変化率 Capacitance Change	初期値の ±30% 以内 Within ±30% of the initial value.	損失角の正接 Dissipation Factor	規格値の 300% 以下 Not more than 300% of the specified value.	漏れ電流 Leakage Current	規格値以下 Not more than the specified value.	<table border="1"> <tr> <td>ケースサイズ Case Size</td> <td>時間(hrs) Time(hrs)</td> </tr> <tr> <td>φ 10</td> <td>3000</td> </tr> <tr> <td>φ D ≥ 12.5</td> <td>5000</td> </tr> </table> ※但し、500Vdc 品は3000 時間 500Vdc:3000hrs	ケースサイズ Case Size	時間(hrs) Time(hrs)	φ 10	3000	φ D ≥ 12.5	5000
静電容量変化率 Capacitance Change	初期値の ±30% 以内 Within ±30% of the initial value.													
損失角の正接 Dissipation Factor	規格値の 300% 以下 Not more than 300% of the specified value.													
漏れ電流 Leakage Current	規格値以下 Not more than the specified value.													
ケースサイズ Case Size	時間(hrs) Time(hrs)													
φ 10	3000													
φ D ≥ 12.5	5000													
低温特性 Low Temperature Stability (インピーダンス比) Impedance Ratio (MAX)	<table border="1"> <tr> <td>定格電圧 (Vdc) Rated Voltage</td> <td>400~450</td> <td>500</td> <td rowspan="3">(120Hz)</td> </tr> <tr> <td>Z(-25°C)/Z(+20°C)</td> <td>6</td> <td>8</td> </tr> <tr> <td>Z(-40°C)/Z(+20°C)</td> <td>10</td> <td>-</td> </tr> </table>		定格電圧 (Vdc) Rated Voltage	400~450	500	(120Hz)	Z(-25°C)/Z(+20°C)	6	8	Z(-40°C)/Z(+20°C)	10	-		
定格電圧 (Vdc) Rated Voltage	400~450	500	(120Hz)											
Z(-25°C)/Z(+20°C)	6	8												
Z(-40°C)/Z(+20°C)	10	-												

◆呼称方法 / PART NUMBER

EXW M D x L
 定格電圧 シリーズ名 静電容量 静電容量許容差 副記号 リード加工記号 ケースサイズ
 Rated Voltage Series Capacitance Capacitance Tolerance Option Lead Forming Case Size

◆リップル電流補正係数 /
MULTIPLIER FOR RIPPLE CURRENT

周波数 (Hz) Frequency	60(50)	120	500	1k	10k	100k ≤	
係数 Coefficient	8.2~82 μF	0.80	1.00	1.30	1.50	2.10	2.50
	100~150 μF	0.80	1.00	1.30	1.50	2.00	2.25

◆副記号 / OPTION

EFR : 400~450Vdc
EFC : 500Vdc

◆寸法図/DIMENSIONS

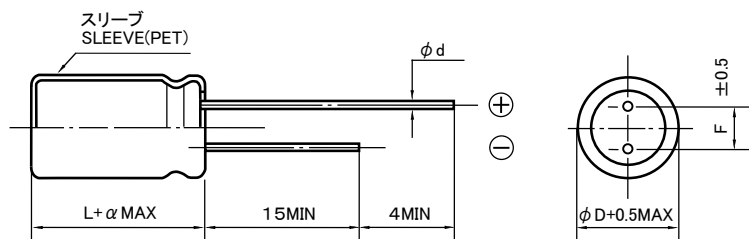

(mm)

φD	10	12.5	14.5	16	18
φd	0.6		0.8		
F	5.0		7.5		
α	2.0				

◆標準品一覧表/STANDARD SIZE

定格電圧 Rated Voltage (Vdc)	静電容量 Capacitance (μF)	外形寸法 Size φD×L (mm)	定格リプル電流 Rated Ripple Current	
			120Hz	100kHz
400	15	10×20	0.200	0.500
	18	10×25	0.235	0.588
	22	10×30	0.275	0.688
	22	12.5×20	0.260	0.650
	27	10×35	0.320	0.800
	27	12.5×25	0.310	0.775
	27	14.5×20	0.310	0.775
	33	10×40	0.370	0.925
	33	10×45	0.380	0.950
	33	16×20	0.355	0.888
	39	10×50	0.425	1.063
	39	12.5×30	0.395	0.988
	39	14.5×25	0.395	0.988
	47	12.5×35	0.455	1.138
	47	14.5×30	0.460	1.150
	47	16×25	0.450	1.125
	47	18×20	0.435	1.088
	56	12.5×40	0.515	1.288
	56	12.5×45	0.535	1.338
	56	14.5×35	0.525	1.313
	68	12.5×50	0.605	1.513
	68	14.5×40	0.595	1.488
	68	16×30	0.565	1.413
	68	18×25	0.550	1.375
	82	14.5×45	0.680	1.700
	82	16×35	0.645	1.613
	82	16×40	0.675	1.688
	82	18×30	0.640	1.600
100	14.5×50	0.770	1.733	
100	16×45	0.770	1.733	
100	18×35	0.740	1.665	
120	16×50	0.865	1.946	
120	18×40	0.835	1.879	
120	18×45	0.870	1.958	
150	18×50	0.995	2.239	

Rated Ripple Current (A r.m.s./125°C)

定格電圧 Rated Voltage (Vdc)	静電容量 Capacitance (μF)	外形寸法 Size φD×L (mm)	定格リプル電流 Rated Ripple Current	
			120Hz	100kHz
420	12	10×20	0.175	0.438
	15	10×25	0.210	0.525
	18	10×30	0.240	0.600
	18	12.5×20	0.230	0.575
	22	10×35	0.280	0.700
	22	14.5×20	0.275	0.688
	27	10×40	0.310	0.775
	27	10×45	0.335	0.838
	27	12.5×25	0.300	0.750
	27	16×20	0.310	0.775
	33	10×50	0.385	0.963
	33	12.5×30	0.355	0.888
	33	14.5×25	0.355	0.888
	39	12.5×35	0.405	1.013
	39	16×25	0.400	1.000
	39	18×20	0.390	0.975
	47	12.5×40	0.460	1.150
	47	12.5×45	0.480	1.200
	47	14.5×30	0.445	1.113
	56	12.5×50	0.535	1.338
	56	14.5×35	0.510	1.275
	56	16×30	0.500	1.250
	56	18×25	0.495	1.238
	68	14.5×40	0.580	1.450
	68	14.5×45	0.600	1.500
	68	16×35	0.580	1.450
	68	18×30	0.575	1.438
	82	14.5×50	0.680	1.700
	82	16×40	0.660	1.650
	82	16×45	0.685	1.713
82	18×35	0.655	1.638	
100	16×50	0.775	1.744	
100	18×40	0.750	1.688	
120	18×45	0.840	1.890	
120	18×50	0.875	1.969	

◆標準品一覧表 / STANDARD SIZE

Rated Ripple Current (A r.m.s./125°C)

定格電圧 Rated Voltage (Vdc)	静電容量 Capacitance (μ F)	外形寸法 Size ϕ D × L (mm)	定格リプル電流 Rated Ripple Current	
			120Hz	100kHz
450	12	10×20	0.175	0.438
	15	10×25	0.210	0.525
	18	10×30	0.240	0.600
	18	12.5×20	0.235	0.588
	22	10×35	0.280	0.700
	22	12.5×25	0.275	0.688
	22	14.5×20	0.275	0.688
	27	10×40	0.325	0.813
	27	10×45	0.335	0.838
	27	12.5×30	0.325	0.813
	27	16×20	0.315	0.788
	33	10×50	0.385	0.963
	33	12.5×35	0.375	0.938
	33	14.5×25	0.355	0.888
	39	12.5×40	0.425	1.063
	39	14.5×30	0.410	1.025
	39	16×25	0.400	1.000
	39	18×20	0.390	0.975
	47	12.5×45	0.480	1.200
	47	14.5×35	0.470	1.175
	47	16×30	0.465	1.163
	47	18×25	0.460	1.150
	56	12.5×50	0.540	1.350
	56	14.5×40	0.530	1.325
	56	16×35	0.530	1.325
	68	14.5×45	0.580	1.450
	68	14.5×50	0.625	1.563
	68	16×40	0.605	1.513
	68	18×30	0.575	1.438
	82	16×45	0.685	1.713
82	18×35	0.660	1.650	
100	16×50	0.775	1.744	
100	18×40	0.740	1.665	
100	18×45	0.785	1.766	
120	18×50	0.880	1.980	

定格電圧 Rated Voltage (Vdc)	静電容量 Capacitance (μ F)	外形寸法 Size ϕ D × L (mm)	定格リプル電流 Rated Ripple Current	
			120Hz	100kHz
500	8.2	10×20	0.135	0.338
	12	10×25	0.180	0.450
	12	12.5×20	0.180	0.450
	15	10×30	0.210	0.525
	18	10×35	0.245	0.613
	18	10×40	0.255	0.638
	18	12.5×25	0.235	0.588
	18	14.5×20	0.235	0.588
	22	10×45	0.280	0.700
	22	12.5×30	0.280	0.700
	22	14.5×25	0.280	0.700
	22	16×20	0.270	0.675
	27	10×50	0.330	0.825
	27	12.5×35	0.320	0.800
	27	14.5×30	0.325	0.813
	27	16×25	0.320	0.800
	27	18×20	0.315	0.788
	33	12.5×40	0.370	0.925
	33	12.5×45	0.385	0.963
	39	12.5×50	0.430	1.075
	39	14.5×35	0.410	1.025
	39	14.5×40	0.425	1.063
	39	16×30	0.405	1.013
	39	18×25	0.400	1.000
	47	14.5×45	0.485	1.213
	47	16×35	0.460	1.150
	47	18×30	0.460	1.150
	56	14.5×50	0.545	1.363
	56	16×40	0.525	1.313
	56	16×45	0.545	1.363
56	18×35	0.525	1.313	
68	16×50	0.615	1.538	
68	18×40	0.600	1.500	
82	18×45	0.680	1.700	
82	18×50	0.700	1.750	

HXW series

105°C 2000~3000時間 超小形化品 -40°C対応
105°C 2000~3000 hours, Ultra Miniaturized, -40°C~+105°C



◆規格表/SPECIFICATIONS

項目 Item	特性 Characteristics																		
カテゴリ温度範囲 Category Temperature Range	-40~+105°C																		
定格電圧範囲 Rated Voltage Range	400~500Vdc																		
静電容量許容差 Capacitance Tolerance	±20%(20°C, 120Hz)																		
漏れ電流 Leakage Current (MAX)	$I=3\sqrt{CV}$ (定格電圧印加5分後) $I=3\sqrt{CV}$ (After 5 minutes application of rated voltage) I=漏れ電流(μA) C=静電容量(μF) V=定格電圧(Vdc) Leakage Current Capacitance Rated Voltage																		
損失角の正接(tan δ) Dissipation Factor (MAX)	<table border="1"> <tr> <td>定格電圧 (Vdc) Rated Voltage</td> <td>400</td> <td>420~500</td> <td>(20°C, 120Hz)</td> </tr> <tr> <td>tan δ</td> <td>0.20</td> <td>0.25</td> <td></td> </tr> </table>	定格電圧 (Vdc) Rated Voltage	400	420~500	(20°C, 120Hz)	tan δ	0.20	0.25											
定格電圧 (Vdc) Rated Voltage	400	420~500	(20°C, 120Hz)																
tan δ	0.20	0.25																	
耐久性 Endurance	<p>105°C中で右表の時間定格電圧(リップル重畳)印加後、下記項目を満足すること。 After applying rated voltage with rated ripple current for specified time at 105°C, the capacitors shall meet the following requirements.</p> <table border="1"> <tr> <td>静電容量変化率 Capacitance Change</td> <td>初期値の ±20% 以内 Within ±20% of the initial value.</td> <td>ケースサイズ Case Size</td> <td>時間(hrs) Time(hrs)</td> </tr> <tr> <td>損失角の正接 Dissipation Factor</td> <td>規格値の 200% 以下 Not more than 200% of the specified value.</td> <td>φD ≤ 12.5</td> <td>2000</td> </tr> <tr> <td>漏れ電流 Leakage Current</td> <td>規格値以下 Not more than the specified value.</td> <td>φD ≥ 14.5</td> <td>L ≤ 25: 2000 L ≥ 30: 3000</td> </tr> </table>	静電容量変化率 Capacitance Change	初期値の ±20% 以内 Within ±20% of the initial value.	ケースサイズ Case Size	時間(hrs) Time(hrs)	損失角の正接 Dissipation Factor	規格値の 200% 以下 Not more than 200% of the specified value.	φD ≤ 12.5	2000	漏れ電流 Leakage Current	規格値以下 Not more than the specified value.	φD ≥ 14.5	L ≤ 25: 2000 L ≥ 30: 3000						
静電容量変化率 Capacitance Change	初期値の ±20% 以内 Within ±20% of the initial value.	ケースサイズ Case Size	時間(hrs) Time(hrs)																
損失角の正接 Dissipation Factor	規格値の 200% 以下 Not more than 200% of the specified value.	φD ≤ 12.5	2000																
漏れ電流 Leakage Current	規格値以下 Not more than the specified value.	φD ≥ 14.5	L ≤ 25: 2000 L ≥ 30: 3000																
低温特性 Low Temperature Stability (インピーダンス比) Impedance Ratio (MAX)	<table border="1"> <tr> <td>定格電圧 (Vdc) Rated Voltage</td> <td>400</td> <td>420</td> <td>450</td> <td>500</td> <td>(120Hz)</td> </tr> <tr> <td>Z(-25°C)/Z(+20°C)</td> <td>5</td> <td>6</td> <td>6</td> <td>8</td> <td></td> </tr> <tr> <td>Z(-40°C)/Z(+20°C)</td> <td>6</td> <td>10</td> <td>10</td> <td>12</td> <td></td> </tr> </table>	定格電圧 (Vdc) Rated Voltage	400	420	450	500	(120Hz)	Z(-25°C)/Z(+20°C)	5	6	6	8		Z(-40°C)/Z(+20°C)	6	10	10	12	
定格電圧 (Vdc) Rated Voltage	400	420	450	500	(120Hz)														
Z(-25°C)/Z(+20°C)	5	6	6	8															
Z(-40°C)/Z(+20°C)	6	10	10	12															

◆呼称方法/PART NUMBER

HXW M D x L
 定格電圧 シリーズ名 静電容量 静電容量許容差 副記号 リード加工記号 ケースサイズ
 Rated Voltage Series Capacitance Capacitance Tolerance Option Lead Forming Case Size

◆リップル電流補正係数/
MULTIPLIER FOR RIPPLE CURRENT

周波数 (Hz) Frequency	60(50)	120	500	1k	10k ≤
係数 Coefficient	0.80	1.00	1.25	1.40	1.50

◆副記号/OPTION

EFR: PETスリーブ PET Sleeve

◆寸法図／DIMENSIONS

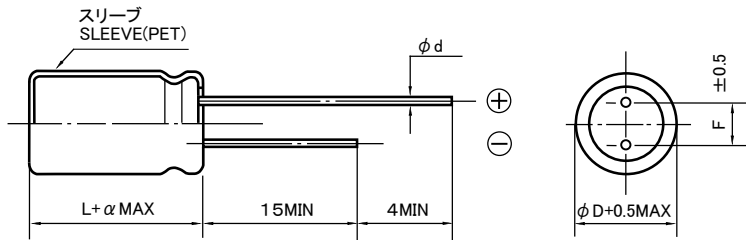

(mm)

ϕD	10	12.5	14.5	16	18
ϕd	0.6		0.8		
F	5.0		7.5		
α	2.0				

◆標準品一覧表／STANDARD SIZE

Rated Ripple Current (A r.m.s./105°C, 120Hz)

定格電圧 Rated Voltage (Vdc)	静電容量 Capacitance (μF)	外形寸法 Size $\phi D \times L$ (mm)	定格リプル 電流 Rated Ripple Current
400	39	12.5x20	0.41
	47	10x30	0.47
	56	10x35	0.54
	56	10x40	0.57
	56	12.5x25	0.53
	56	14.5x20	0.52
	68	10x45	0.65
	68	12.5x30	0.61
	68	14.5x25	0.62
	68	16x20	0.59
	82	10x50	0.73
	82	10x55	0.75
	82	10x60	0.78
	82	12.5x35	0.70
	82	14.5x30	0.71
	82	18x20	0.67
	100	12.5x40	0.80
	100	12.5x45	0.84
	100	14.5x35	0.82
	100	16x25	0.74
	120	12.5x50	0.95
	120	14.5x40	0.93
	120	16x30	0.87
	120	18x25	0.85
	150	14.5x45	1.07
	150	14.5x50	1.11
	150	16x35	1.00
	150	16x40	1.07
	150	18x30	1.00
	180	16x45	1.20
180	18x35	1.14	
220	16x50	1.34	
220	18x40	1.30	
220	18x45	1.36	
270	18x50	1.53	

定格電圧 Rated Voltage (Vdc)	静電容量 Capacitance (μF)	外形寸法 Size $\phi D \times L$ (mm)	定格リプル 電流 Rated Ripple Current
420	39	10x30	0.40
	39	12.5x20	0.38
	47	10x35	0.46
	47	12.5x25	0.45
	47	14.5x20	0.45
	56	10x40	0.52
	56	16x20	0.50
	68	10x45	0.60
	68	10x50	0.62
	68	12.5x30	0.57
	68	14.5x25	0.57
	82	10x55	0.70
	82	10x60	0.71
	82	12.5x35	0.64
	82	12.5x40	0.68
	82	14.5x30	0.66
	82	16x25	0.64
	82	18x20	0.62
	100	12.5x45	0.78
	100	14.5x35	0.76
	100	16x30	0.75
	120	12.5x50	0.86
	120	14.5x40	0.86
	120	14.5x45	0.90
	120	16x35	0.85
	120	18x25	0.78
	150	14.5x50	1.03
	150	16x40	0.99
	150	18x30	0.92
	180	16x45	1.11
180	16x50	1.15	
180	18x35	1.05	
180	18x40	1.11	
220	18x45	1.26	
270	18x50	1.40	

◆標準品一覧表／STANDARD SIZE

Rated Ripple Current(A r.m.s./105°C, 120Hz)

定格電圧 Rated Voltage (Vdc)	静電容量 Capacitance (μ F)	外形寸法 Size ϕ D×L(mm)	定格リプル 電流 RatedRipple Current
450	33	12.5×20	0.36
	39	10×30	0.40
	47	10×35	0.46
	47	12.5×25	0.45
	47	14.5×20	0.44
	56	10×40	0.51
	56	10×45	0.55
	56	12.5×30	0.52
	56	14.5×25	0.52
	56	16×20	0.50
	68	10×50	0.62
	68	10×55	0.64
	68	12.5×35	0.60
	68	18×20	0.57
	82	10×60	0.71
	82	12.5×40	0.68
	82	12.5×45	0.71
	82	14.5×30	0.66
	82	16×25	0.64
	100	12.5×50	0.81
	100	14.5×35	0.75
	100	14.5×40	0.79
	100	16×30	0.75
	100	18×25	0.73
	120	14.5×45	0.90
	120	14.5×50	0.93
	120	16×35	0.86
	120	18×30	0.84
	150	16×40	0.97
	150	16×45	1.03
150	18×35	0.98	
180	16×50	1.15	
180	18×40	1.11	
220	18×45	1.24	
220	18×50	1.30	

定格電圧 Rated Voltage (Vdc)	静電容量 Capacitance (μ F)	外形寸法 Size ϕ D×L(mm)	定格リプル 電流 RatedRipple Current
500	22	12.5×20	0.26
	27	12.5×25	0.33
	27	14.5×20	0.33
	33	14.5×25	0.38
	33	16×20	0.37
	33	12.5×30	0.38
	39	12.5×35	0.44
	47	12.5×40	0.50
	47	14.5×30	0.48
	47	16×25	0.48
	47	18×20	0.45
	56	12.5×45	0.57
	56	12.5×50	0.58
	56	14.5×35	0.56
	56	16×30	0.55
	56	18×25	0.54
	68	14.5×40	0.63
	68	14.5×45	0.71
	68	16×35	0.62
	68	18×30	0.68
	82	14.5×50	0.74
	82	16×40	0.71
	82	16×45	0.81
	82	18×35	0.78
	100	16×50	0.83
	100	18×40	0.88
	120	18×45	0.92
	120	18×50	0.95

LXW series

105°C長寿命(10000~12000時間)超小形化品 -40°C対応
105°C 10000~12000 hours, Ultra Miniaturized, -40°C~+105°C



◆規格表/SPECIFICATIONS

項目 Item	特性 Characteristics																		
カテゴリ温度範囲 Category Temperature Range	-40~+105°C																		
定格電圧範囲 Rated Voltage Range	400~500Vdc																		
静電容量許容差 Capacitance Tolerance	±20%(20°C, 120Hz)																		
漏れ電流 Leakage Current (MAX)	$I=3\sqrt{CV}$ (定格電圧印加5分後) $I=3\sqrt{CV}$ (After 5 minutes application of rated voltage) I=漏れ電流(μA) C=静電容量(μF) V=定格電圧(Vdc) Leakage Current Capacitance Rated Voltage																		
損失角の正接(tan δ) Dissipation Factor (MAX)	<table border="1"> <tr> <td>定格電圧 (Vdc) Rated Voltage</td> <td>400</td> <td>420~500</td> <td>(20°C, 120Hz)</td> </tr> <tr> <td>tan δ</td> <td>0.20</td> <td>0.25</td> <td></td> </tr> </table>	定格電圧 (Vdc) Rated Voltage	400	420~500	(20°C, 120Hz)	tan δ	0.20	0.25											
定格電圧 (Vdc) Rated Voltage	400	420~500	(20°C, 120Hz)																
tan δ	0.20	0.25																	
耐久性 Endurance	<p>105°C中で右表の時間定格電圧(リップル重畳)印加後、下記項目を満足すること。 After applying rated voltage with rated ripple current for specified time at 105°C, the capacitors shall meet the following requirements.</p> <table border="1"> <tr> <td>静電容量変化率 Capacitance Change</td> <td>初期値の ±20% 以内 Within ±20% of the initial value.</td> <td>ケースサイズ Case Size</td> <td>時間(hrs) Time(hrs)</td> </tr> <tr> <td>損失角の正接 Dissipation Factor</td> <td>規格値の 200% 以下 Not more than 200% of the specified value.</td> <td>L ≤ 20</td> <td>10000</td> </tr> <tr> <td>漏れ電流 Leakage Current</td> <td>規格値以下 Not more than the specified value.</td> <td>L ≥ 25</td> <td>12000</td> </tr> </table>	静電容量変化率 Capacitance Change	初期値の ±20% 以内 Within ±20% of the initial value.	ケースサイズ Case Size	時間(hrs) Time(hrs)	損失角の正接 Dissipation Factor	規格値の 200% 以下 Not more than 200% of the specified value.	L ≤ 20	10000	漏れ電流 Leakage Current	規格値以下 Not more than the specified value.	L ≥ 25	12000						
静電容量変化率 Capacitance Change	初期値の ±20% 以内 Within ±20% of the initial value.	ケースサイズ Case Size	時間(hrs) Time(hrs)																
損失角の正接 Dissipation Factor	規格値の 200% 以下 Not more than 200% of the specified value.	L ≤ 20	10000																
漏れ電流 Leakage Current	規格値以下 Not more than the specified value.	L ≥ 25	12000																
低温特性 Low Temperature Stability (インピーダンス比) Impedance Ratio (MAX)	<table border="1"> <tr> <td>定格電圧 (Vdc) Rated Voltage</td> <td>400</td> <td>420</td> <td>450</td> <td>500</td> <td>(120Hz)</td> </tr> <tr> <td>Z(-25°C)/Z(+20°C)</td> <td>5</td> <td>6</td> <td>6</td> <td>8</td> <td></td> </tr> <tr> <td>Z(-40°C)/Z(+20°C)</td> <td>6</td> <td>10</td> <td>10</td> <td>12</td> <td></td> </tr> </table>	定格電圧 (Vdc) Rated Voltage	400	420	450	500	(120Hz)	Z(-25°C)/Z(+20°C)	5	6	6	8		Z(-40°C)/Z(+20°C)	6	10	10	12	
定格電圧 (Vdc) Rated Voltage	400	420	450	500	(120Hz)														
Z(-25°C)/Z(+20°C)	5	6	6	8															
Z(-40°C)/Z(+20°C)	6	10	10	12															

◆呼称方法/PART NUMBER

□□□ LXW □□□□□ M □□□ □□ D x L
 定格電圧 シリーズ名 静電容量 静電容量許容差 副記号 リード加工記号 ケースサイズ
 Rated Voltage Series Capacitance Capacitance Tolerance Option Lead Forming Case Size

◆リップル電流補正係数/
MULTIPLIER FOR RIPPLE CURRENT

周波数 (Hz) Frequency	60(50)	120	500	1k	10k	100k ≤
18~82 μF	0.80	1.00	1.30	1.50	2.00	2.20
100~220 μF	0.80	1.00	1.30	1.50	1.90	2.00

◆副記号/OPTION

EFR : PETスリーブ PET Sleeve

◆寸法図／DIMENSIONS

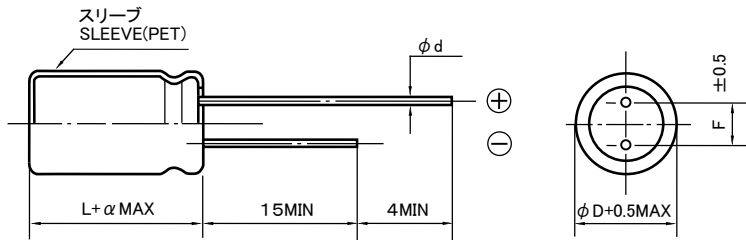

		(mm)				
φD		10	12.5	14.5	16	18
φd		0.6		0.8		
F		5.0		7.5		
α		2.0				

◆標準品一覧表／STANDARD SIZE

Rated Ripple Current (A r.m.s./105°C)

定格電圧 Rated Voltage (Vdc)	静電容量 Capacitance (μF)	外形寸法 Size φD × L (mm)	定格リプル電流 Rated Ripple Current	
			120Hz	100kHz
400	39	10×30	0.410	0.902
	39	12.5×20	0.390	0.858
	47	10×35	0.480	1.056
	47	12.5×25	0.460	1.012
	47	14.5×20	0.460	1.012
	56	10×40	0.540	1.188
	56	16×20	0.520	1.144
	68	10×45	0.610	1.342
	68	10×50	0.640	1.408
	68	12.5×30	0.580	1.276
	68	12.5×35	0.620	1.364
	68	14.5×25	0.590	1.298
	82	10×55	0.720	1.584
	82	10×60	0.740	1.628
	82	12.5×40	0.700	1.540
	82	14.5×30	0.680	1.496
	82	16×25	0.660	1.452
	82	18×20	0.630	1.386
	100	12.5×45	0.800	1.600
	100	12.5×50	0.830	1.660
	100	14.5×35	0.780	1.560
	100	16×30	0.770	1.540
	120	14.5×40	0.890	1.780
	120	14.5×45	0.920	1.840
	120	16×35	0.880	1.760
	120	18×25	0.790	1.580
	150	14.5×50	1.060	2.120
	150	16×40	1.010	2.020
150	18×30	0.930	1.860	
180	16×45	1.140	2.280	
180	16×50	1.180	2.360	
180	18×35	1.060	2.120	
180	18×40	1.140	2.280	
220	18×45	1.290	2.580	
220	18×50	1.340	2.680	

定格電圧 Rated Voltage (Vdc)	静電容量 Capacitance (μF)	外形寸法 Size φD × L (mm)	定格リプル電流 Rated Ripple Current	
			120Hz	100kHz
420	33	12.5×20	0.340	0.748
	39	10×30	0.380	0.836
	47	10×35	0.440	0.968
	47	12.5×25	0.430	0.946
	47	14.5×20	0.420	0.924
	56	10×40	0.490	1.078
	56	10×45	0.520	1.144
	56	12.5×30	0.500	1.100
	56	14.5×25	0.500	1.100
	56	16×20	0.480	1.056
	68	10×50	0.590	1.298
	68	10×55	0.610	1.342
	68	12.5×35	0.570	1.254
	68	18×20	0.550	1.210
	82	10×60	0.680	1.496
	82	12.5×40	0.650	1.430
	82	14.5×30	0.630	1.386
	82	16×25	0.610	1.342
	100	12.5×45	0.730	1.460
	100	12.5×50	0.770	1.540
	100	14.5×35	0.720	1.440
	100	14.5×40	0.760	1.520
	100	16×30	0.720	1.440
	100	18×25	0.700	1.400
	120	14.5×45	0.860	1.720
	120	14.5×50	0.890	1.780
	120	16×35	0.820	1.640
	120	18×30	0.810	1.620
150	16×40	0.930	1.860	
150	16×45	0.980	1.960	
150	18×35	0.940	1.880	
180	16×50	1.100	2.200	
180	18×40	1.060	2.120	
220	18×45	1.200	2.400	
220	18×50	1.250	2.500	

◆標準品一覧表 / STANDARD SIZE

Rated Ripple Current (A r.m.s./105°C)

定格電圧 Rated Voltage (Vdc)	静電容量 Capacitance (μ F)	外形寸法 Size ϕ D × L (mm)	定格リプル電流 Rated Ripple Current	
			120Hz	100kHz
450	27	12.5×20	0.310	0.682
	33	10×30	0.360	0.792
	39	10×35	0.410	0.902
	39	12.5×25	0.400	0.880
	39	14.5×20	0.390	0.858
	47	10×40	0.460	1.012
	47	16×20	0.450	0.990
	56	10×45	0.520	1.144
	56	10×50	0.540	1.188
	56	12.5×30	0.490	1.078
	56	14.5×25	0.500	1.100
	68	10×55	0.610	1.342
	68	10×60	0.630	1.386
	68	12.5×35	0.560	1.232
	68	12.5×40	0.600	1.320
	68	14.5×30	0.580	1.276
	68	16×25	0.570	1.254
	68	18×20	0.540	1.188
	82	12.5×45	0.680	1.496
	82	12.5×50	0.700	1.540
	82	14.5×35	0.670	1.474
	82	16×30	0.650	1.430
	82	18×25	0.640	1.408
	100	14.5×40	0.760	1.520
	100	16×35	0.750	1.500
	120	14.5×45	0.850	1.700
	120	14.5×50	0.890	1.780
	120	16×40	0.860	1.720
	120	18×30	0.800	1.600
	150	16×45	0.980	1.960
150	16×50	1.020	2.040	
150	18×35	0.920	1.840	
150	18×40	0.980	1.960	
180	18×45	1.110	2.220	
220	18×50	1.230	2.460	

定格電圧 Rated Voltage (Vdc)	静電容量 Capacitance (μ F)	外形寸法 Size ϕ D × L (mm)	定格リプル電流 Rated Ripple Current	
			120Hz	100kHz
500	18	12.5×20	0.250	0.550
	22	12.5×25	0.290	0.638
	22	14.5×20	0.280	0.616
	27	16×20	0.320	0.704
	33	12.5×30	0.360	0.792
	33	12.5×35	0.380	0.836
	33	14.5×25	0.370	0.814
	39	12.5×40	0.440	0.968
	39	12.5×45	0.500	1.100
	39	14.5×30	0.430	0.946
	39	16×25	0.420	0.924
	39	18×20	0.410	0.902
	47	12.5×50	0.560	1.232
	47	14.5×35	0.490	1.078
	47	16×30	0.480	1.056
	56	14.5×40	0.550	1.210
	56	14.5×45	0.620	1.364
	56	16×35	0.590	1.298
	56	18×25	0.510	1.122
	56	18×30	0.590	1.298
	68	14.5×50	0.690	1.518
	68	16×40	0.620	1.364
	82	16×45	0.710	1.562
	82	16×50	0.790	1.738
	82	18×35	0.680	1.496
	82	18×40	0.770	1.694
	100	18×45	0.860	1.720
	120	18×50	0.910	1.820

QXW series

105°C 2000時間 小形化品, -40°C対応
105°C 2000hours, Miniaturized, Temp. Range : -40~+105°C



◆規格表/SPECIFICATIONS

項目 Item	特性 Characteristics									
カテゴリ温度範囲 Category Temperature Range	-40~+105°C									
定格電圧範囲 Rated Voltage Range	200~450Vdc									
静電容量許容差 Capacitance Tolerance	±20%(20°C, 120Hz)									
漏れ電流 Leakage Current (MAX)	$I=3\sqrt{CV}$ (定格電圧印加5分後) $I=3\sqrt{CV}$ (After 5 minutes application of rated voltage) I =漏れ電流(μA) C =静電容量(μF) V =定格電圧(Vdc) Leakage Current Capacitance Rated Voltage									
損失角の正接(tan δ) Dissipation Factor (MAX)	<table border="1"> <tr> <td>定格電圧 (Vdc) Rated Voltage</td> <td>200, 400</td> <td>420, 450</td> <td rowspan="2">(20°C, 120Hz)</td> </tr> <tr> <td>tan δ</td> <td>0.15</td> <td>0.20</td> </tr> </table>	定格電圧 (Vdc) Rated Voltage	200, 400	420, 450	(20°C, 120Hz)	tan δ	0.15	0.20		
定格電圧 (Vdc) Rated Voltage	200, 400	420, 450	(20°C, 120Hz)							
tan δ	0.15	0.20								
耐久性 Endurance	<p>105°C中で2000時間定格電圧(リップル重畳)印加後、下記項目を満足すること。 After applying rated voltage with rated ripple current for 2000 hours at 105°C, the capacitors shall meet the following requirements.</p> <table border="1"> <tr> <td>静電容量変化率 Capacitance Change</td> <td>初期値の ±20% 以内 Within ±20% of the initial value.</td> </tr> <tr> <td>損失角の正接 Dissipation Factor</td> <td>規格値の 200% 以下 Not more than 200% of the specified value.</td> </tr> <tr> <td>漏れ電流 Leakage Current</td> <td>規格値以下 Not more than the specified value.</td> </tr> </table>	静電容量変化率 Capacitance Change	初期値の ±20% 以内 Within ±20% of the initial value.	損失角の正接 Dissipation Factor	規格値の 200% 以下 Not more than 200% of the specified value.	漏れ電流 Leakage Current	規格値以下 Not more than the specified value.			
静電容量変化率 Capacitance Change	初期値の ±20% 以内 Within ±20% of the initial value.									
損失角の正接 Dissipation Factor	規格値の 200% 以下 Not more than 200% of the specified value.									
漏れ電流 Leakage Current	規格値以下 Not more than the specified value.									
低温特性 Low Temperature Stability (インピーダンス比) Impedance Ratio (MAX)	<table border="1"> <tr> <td>定格電圧 (Vdc) Rated Voltage</td> <td>200</td> <td>400</td> <td>420, 450</td> <td rowspan="2">(120Hz)</td> </tr> <tr> <td>Z(-25°C)/Z(+20°C)</td> <td>3</td> <td>5</td> <td>6</td> </tr> </table>	定格電圧 (Vdc) Rated Voltage	200	400	420, 450	(120Hz)	Z(-25°C)/Z(+20°C)	3	5	6
定格電圧 (Vdc) Rated Voltage	200	400	420, 450	(120Hz)						
Z(-25°C)/Z(+20°C)	3	5	6							

◆呼称方法/PART NUMBER

QXW M EFR D x L
 定格電圧 シリーズ名 静電容量 静電容量許容差 副記号 リード加工記号 ケースサイズ
 Rated Voltage Series Capacitance Capacitance Tolerance Option Lead Forming Case Size

◆リップル電流補正係数/
MULTIPLIER FOR RIPPLE CURRENT

周波数 (Hz) Frequency	60(50)	120	500	1k	10k ≤
係数 Coefficient	0.80	1.00	1.25	1.40	1.50

◆副記号/OPTION

EFR : PETスリーブ PET Sleeve

◆寸法図/DIMENSIONS

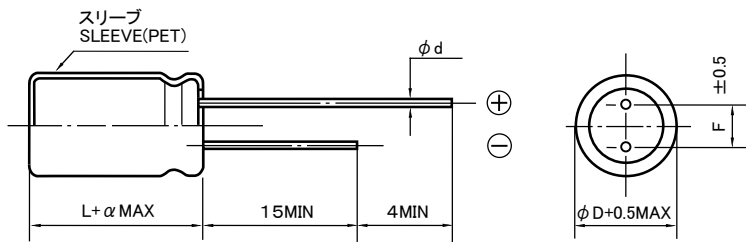

(mm)

φD	8	10	12.5	14.5	16	18
φd	0.6			0.8		
F	3.5	5.0		7.5		
α	2.0					

◆標準品一覧表/STANDARD SIZE

Rated Ripple Current (A r.m.s./105°C, 120Hz)

定格電圧 Rated Voltage (Vdc)	静電容量 Capacitance (μF)	外形寸法 Size φD × L(mm)	定格リプル 電流 Rated Ripple Current
200	82	10×30	0.51
	100	10×35	0.60
	120	10×40	0.68
	150	12.5×30	0.73
	180	12.5×35	0.85
	220	12.5×40	0.97
	220	14.5×30	0.89
	270	14.5×35	1.04
	270	16×30	1.01
	330	16×35	1.17
	330	18×30	1.17
	390	16×40	1.33
	390	18×35	1.33
	470	18×40	1.53
560	18×45	1.73	
400	18	8×25	0.19
	22	8×30	0.22
	27	8×35	0.25
	33	8×45	0.33
	33	10×30	0.33
	39	8×50	0.35
	39	10×35	0.37
	47	10×40	0.43
	56	10×45	0.48
	56	12.5×30	0.47
	68	12.5×35	0.54
	82	12.5×40	0.62
	82	14.5×31.5	0.61
	100	12.5×50	0.73
	100	14.5×35	0.70
	100	16×31.5	0.71
	120	14.5×40	0.79
	120	16×35	0.80
	150	14.5×50	0.94
	150	16×40	0.92
	150	18×31.5	0.89
	180	16×50	1.08
180	18×40	1.06	
220	18×45	1.20	

定格電圧 Rated Voltage (Vdc)	静電容量 Capacitance (μF)	外形寸法 Size φD × L(mm)	定格リプル 電流 Rated Ripple Current
420	15	8×25	0.12
	18	8×30	0.14
	22	8×40	0.22
	27	8×45	0.26
	33	10×30	0.32
	39	10×35	0.36
	47	10×40	0.41
	56	10×50	0.49
	56	12.5×30	0.46
	68	12.5×35	0.53
	82	12.5×45	0.63
	82	14.5×31.5	0.60
	100	12.5×50	0.71
	100	14.5×40	0.72
	100	16×31.5	0.69
	120	14.5×45	0.81
	120	16×35	0.78
	120	18×31.5	0.80
	150	16×45	0.94
	150	18×35	0.92
180	16×50	1.05	
180	18×40	1.04	
220	18×50	1.22	
450	12	8×25	0.15
	15	8×30	0.17
	18	8×35	0.19
	22	8×45	0.23
	27	10×30	0.30
	33	10×35	0.34
	39	10×40	0.39
	47	10×45	0.44
	47	12.5×30	0.43
	56	12.5×35	0.49
	68	12.5×40	0.56
	68	14.5×31.5	0.56
	82	12.5×45	0.63
	82	14.5×35	0.63
	82	16×31.5	0.64
	100	14.5×40	0.72
	100	16×35	0.73
	120	14.5×50	0.85
	120	16×40	0.82
	120	18×31.5	0.80
	150	16×50	0.98
	150	18×40	0.97
	180	18×45	1.09
	220	18×50	1.22

TXW series

105°C 長寿命(7000~10000時間) 小形化品 -40°C対応
105°C 7000~10000 hours, Miniaturized, -40°C~+105°C

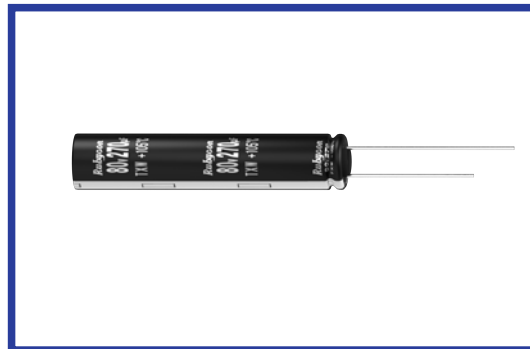

◆規格表/SPECIFICATIONS

項目 Item	特性 Characteristics																					
カテゴリ温度範囲 Category Temperature Range	-40~+105°C																					
定格電圧範囲 Rated Voltage Range	35~100Vdc																					
静電容量許容差 Capacitance Tolerance	±20%(20°C, 120Hz)																					
漏れ電流 Leakage Current (MAX)	I=0.01CV又は3μAのいずれか大なる値以下(定格電圧印加2分後) I=0.01CV or 3 μA whichever is greater. (After 2 minutes)																					
	I=漏れ電流(μA) C=静電容量(μF) V=定格電圧(Vdc) Leakage Current Capacitance Rated Voltage																					
損失角の正接(tan δ) Dissipation Factor (MAX)	<table border="1"> <tr> <td>定格電圧 (Vdc) Rated Voltage</td> <td>35</td> <td>50</td> <td>63</td> <td>80</td> <td>100</td> <td>160~400</td> <td>420, 450</td> <td>(20°C, 120Hz)</td> </tr> <tr> <td>tan δ</td> <td>0.12</td> <td>0.10</td> <td>0.09</td> <td>0.08</td> <td>0.08</td> <td>0.20</td> <td>0.25</td> <td></td> </tr> </table>	定格電圧 (Vdc) Rated Voltage	35	50	63	80	100	160~400	420, 450	(20°C, 120Hz)	tan δ	0.12	0.10	0.09	0.08	0.08	0.20	0.25				
定格電圧 (Vdc) Rated Voltage	35	50	63	80	100	160~400	420, 450	(20°C, 120Hz)														
tan δ	0.12	0.10	0.09	0.08	0.08	0.20	0.25															
耐久性 Endurance	<p>105°C中で右表の時間定格電圧(リップル重畳)印加後、下記項目を満足すること。 After applying rated voltage with rated ripple current for specified time at 105°C, the capacitors shall meet the following requirements.</p> <table border="1"> <tr> <td>静電容量変化率 Capacitance Change</td> <td>初期値の±25%以内 Within ±25% of the initial value.</td> <td rowspan="3"> <table border="1"> <tr> <td>ケースサイズ Case Size</td> <td>時間(hrs) Time(hrs)</td> </tr> <tr> <td>φ 6.3</td> <td>7000</td> </tr> <tr> <td>φ D ≥ 8</td> <td>10000</td> </tr> </table> </td> </tr> <tr> <td>損失角の正接 Dissipation Factor</td> <td>規格値の 200% Not more than 200% of the specified value.</td> </tr> <tr> <td>漏れ電流 Leakage Current</td> <td>規格値以下 Not more than the specified value.</td> </tr> </table>	静電容量変化率 Capacitance Change	初期値の±25%以内 Within ±25% of the initial value.	<table border="1"> <tr> <td>ケースサイズ Case Size</td> <td>時間(hrs) Time(hrs)</td> </tr> <tr> <td>φ 6.3</td> <td>7000</td> </tr> <tr> <td>φ D ≥ 8</td> <td>10000</td> </tr> </table>	ケースサイズ Case Size	時間(hrs) Time(hrs)	φ 6.3	7000	φ D ≥ 8	10000	損失角の正接 Dissipation Factor	規格値の 200% Not more than 200% of the specified value.	漏れ電流 Leakage Current	規格値以下 Not more than the specified value.								
静電容量変化率 Capacitance Change	初期値の±25%以内 Within ±25% of the initial value.	<table border="1"> <tr> <td>ケースサイズ Case Size</td> <td>時間(hrs) Time(hrs)</td> </tr> <tr> <td>φ 6.3</td> <td>7000</td> </tr> <tr> <td>φ D ≥ 8</td> <td>10000</td> </tr> </table>	ケースサイズ Case Size		時間(hrs) Time(hrs)	φ 6.3	7000	φ D ≥ 8	10000													
ケースサイズ Case Size	時間(hrs) Time(hrs)																					
φ 6.3	7000																					
φ D ≥ 8	10000																					
損失角の正接 Dissipation Factor	規格値の 200% Not more than 200% of the specified value.																					
漏れ電流 Leakage Current	規格値以下 Not more than the specified value.																					
低温特性 Low Temperature Stability (インピーダンス比) Impedance Ratio (MAX)	<table border="1"> <tr> <td>定格電圧 (Vdc) Rated Voltage</td> <td>35</td> <td>50</td> <td>63</td> <td>80</td> <td>100</td> <td>(120Hz)</td> </tr> <tr> <td>Z(-25°C)/Z(+20°C)</td> <td>2</td> <td>2</td> <td>2</td> <td>2</td> <td>2</td> <td></td> </tr> <tr> <td>Z(-40°C)/Z(+20°C)</td> <td>3</td> <td>3</td> <td>3</td> <td>3</td> <td>3</td> <td></td> </tr> </table>	定格電圧 (Vdc) Rated Voltage	35	50	63	80	100	(120Hz)	Z(-25°C)/Z(+20°C)	2	2	2	2	2		Z(-40°C)/Z(+20°C)	3	3	3	3	3	
定格電圧 (Vdc) Rated Voltage	35	50	63	80	100	(120Hz)																
Z(-25°C)/Z(+20°C)	2	2	2	2	2																	
Z(-40°C)/Z(+20°C)	3	3	3	3	3																	

◆呼称方法/PART NUMBER

□□□ TXW □□□□□ M □□□ □□ D x L
 定格電圧 シリーズ名 静電容量 静電容量許容差 副記号 リード加工記号 ケースサイズ
 Rated Voltage Series Capacitance Capacitance Tolerance Option Lead Forming Case Size

◆副記号/OPTION

EFC : PETスリーブ PET Sleeve

◆リップル電流補正係数/MULTIPLIER FOR RIPPLE CURRENT

Frequency (Hz)	120	1k	10k	100k ≤	
係数 Coefficient	33 μF	0.42	0.70	0.90	1.00
	39~270 μF	0.50	0.73	0.92	1.00
	330~680 μF	0.55	0.77	0.94	1.00
	820~1800 μF	0.60	0.80	0.96	1.00

◆寸法図／DIMENSIONS

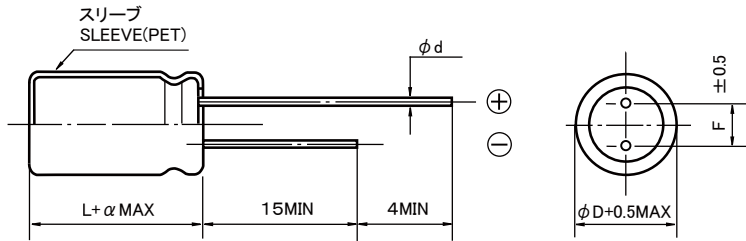

(mm)

ϕD	6.3	8	10
ϕd	0.5	0.6	
F	2.5	3.5	5.0
α	2.0		

◆標準品一覧表／STANDARD SIZE

定格電圧 Rated Voltage (Vdc)	静電容量 Capacitance (μF)	外形寸法 Size $\phi D \times L$ (mm)	定格リップル電流 Rated Ripple Current	
			120Hz	100kHz
35	180	6.3x25	0.605	1.21
	220	6.3x30	0.685	1.37
	330	6.3x40	0.924	1.68
	390	6.3x50	1.11	2.02
	390	8x25	0.951	1.73
	470	8x30	1.11	2.03
	680	8x40	1.41	2.57
	820	8x50	1.82	3.04
	820	10x30	1.48	2.47
	1000	8x60	2.08	3.48
	1200	10x40	1.87	3.12
	1500	10x50	2.21	3.69
	1800	10x60	2.50	4.17
50	100	6.3x25	0.51	1.02
	120	6.3x30	0.58	1.16
	180	6.3x40	0.71	1.42
	220	6.3x50	0.86	1.72
	220	8x25	0.74	1.48
	270	8x30	0.87	1.74
	390	8x40	1.22	2.23
	470	8x50	1.45	2.65
	470	10x30	1.22	2.22
	560	8x60	1.68	3.07
	680	10x40	1.55	2.82
	820	10x50	2.02	3.37
	1000	10x60	2.31	3.86
63	82	6.3x25	0.455	0.91
	100	6.3x30	0.515	1.03
	150	6.3x40	0.635	1.27
	180	6.3x50	0.775	1.55
	180	8x25	0.665	1.33
	220	8x30	0.785	1.57
	330	8x40	1.11	2.02
	390	8x50	1.32	2.41
	390	10x30	1.16	2.10
	470	8x60	1.54	2.80
	560	10x40	1.43	2.60
	680	10x50	1.71	3.12
	820	10x60	2.15	3.59
80	47	6.3x25	0.455	0.91
	56	6.3x30	0.515	1.03
	82	6.3x40	0.635	1.27
	100	6.3x50	0.775	1.55
	100	8x25	0.665	1.33
	120	8x30	0.785	1.57
	180	8x40	1.01	2.02
	220	8x50	1.20	2.41
	220	10x30	1.05	2.10
	270	8x60	1.40	2.80
	270	10x40	1.30	2.60

Rated Ripple Current (A r.m.s./105°C)

定格電圧 Rated Voltage (Vdc)	静電容量 Capacitance (μF)	外形寸法 Size $\phi D \times L$ (mm)	定格リップル電流 Rated Ripple Current	
			120Hz	100kHz
80	390	10x50	1.71	3.12
	470	10x60	1.97	3.59
100	33	6.3x25	0.382	0.91
	39	6.3x30	0.515	1.03
	56	6.3x40	0.635	1.27
	68	6.3x50	0.775	1.55
	82	8x25	0.665	1.33
	100	8x30	0.785	1.57
	120	8x40	1.01	2.02
	150	8x50	1.20	2.41
	150	10x30	1.05	2.10
	220	8x60	1.40	2.80
	220	10x40	1.30	2.60
270	10x50	1.56	3.12	
330	10x60	1.97	3.59	

SBW series

105°C 過電圧弁作動規格設定 小形化品
105°C Overvoltage Venting Specification, Miniaturized

- 105°C 2000時間品
Load Life : 105°C 2000hours
- コンデンサに過電圧が印加された状態における弁作動規格を設定した製品です。
詳細については、お問い合わせください。
This series has specification of vent operation in overvoltage situation.
Please consult us for any further details.

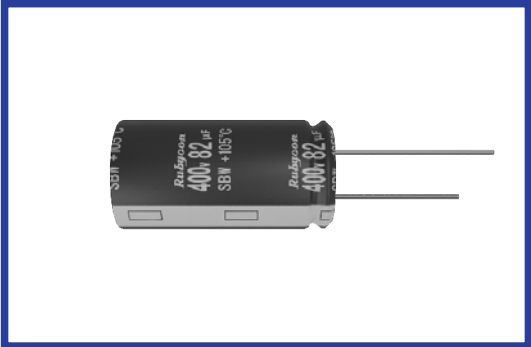

◆規格表/SPECIFICATIONS

項目 Item	特性 Characteristics							
カテゴリ温度範囲 Category Temperature Range	-25~+105°C							
定格電圧範囲 Rated Voltage Range	400Vdc							
静電容量許容差 Capacitance Tolerance	±20% (20°C, 120Hz)							
漏れ電流 Leakage Current (MAX)	$I=3\sqrt{CV}$ (定格電圧印加5分後) $I=3\sqrt{CV}$ (After 5 minutes application of rated voltage) I=漏れ電流(μA) C=静電容量(μF) V=定格電圧(Vdc) Leakage Current Capacitance Rated Voltage							
損失角の正接 (tan δ) Dissipation Factor(MAX)	<table border="1"> <tr> <td>定格電圧 (Vdc) Rated Voltage</td> <td>400</td> <td>(20°C, 120Hz)</td> </tr> <tr> <td>tan δ</td> <td>0.15</td> <td></td> </tr> </table>	定格電圧 (Vdc) Rated Voltage	400	(20°C, 120Hz)	tan δ	0.15		
定格電圧 (Vdc) Rated Voltage	400	(20°C, 120Hz)						
tan δ	0.15							
耐久性 Endurance	105°C中で2000時間定格電圧(リプル重畳)印加後、下記項目を満足すること。 After applying rated voltage with rated ripple current for 2000 hours at 105°C, the capacitors shall meet the following requirements.							
	<table border="1"> <tr> <td>静電容量変化率 Capacitance Change</td> <td>初期値の±20%以内 Within ±20% of the initial value.</td> </tr> <tr> <td>損失角の正接 Dissipation Factor</td> <td>規格値の200%以下 Not more than 200% of the specified value.</td> </tr> <tr> <td>漏れ電流 Leakage Current</td> <td>規格値以下 Not more than the specified value.</td> </tr> </table>	静電容量変化率 Capacitance Change	初期値の±20%以内 Within ±20% of the initial value.	損失角の正接 Dissipation Factor	規格値の200%以下 Not more than 200% of the specified value.	漏れ電流 Leakage Current	規格値以下 Not more than the specified value.	
静電容量変化率 Capacitance Change	初期値の±20%以内 Within ±20% of the initial value.							
損失角の正接 Dissipation Factor	規格値の200%以下 Not more than 200% of the specified value.							
漏れ電流 Leakage Current	規格値以下 Not more than the specified value.							
低温特性 Low Temperature Stability (インピーダンス比) Impedance Ratio (MAX)	<table border="1"> <tr> <td>定格電圧 (Vdc) Rated Voltage</td> <td>400</td> <td>(120Hz)</td> </tr> <tr> <td>Z(-25°C) / Z(20°C)</td> <td>8</td> <td></td> </tr> </table>	定格電圧 (Vdc) Rated Voltage	400	(120Hz)	Z(-25°C) / Z(20°C)	8		
定格電圧 (Vdc) Rated Voltage	400	(120Hz)						
Z(-25°C) / Z(20°C)	8							

◆寸法図/DIMENSIONS

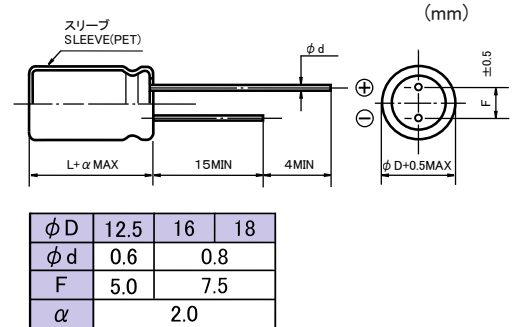

◆標準品一覧表/STANDARD SIZE

Rated Ripple Current (A r.m.s./105°C,120Hz)

定格電圧 Rated Voltage (Vdc)	静電容量 Capacitance (μF)	外形寸法 Size φD×L (mm)	定格リプル電流 Rated Ripple Current
400	18	12.5×20	0.19
	22	12.5×20	0.21
	27	12.5×25	0.25
	27	16×20	0.25
	33	12.5×25	0.27
	33	16×20	0.27
	39	12.5×30	0.32
	39	16×20	0.29
	47	16×25	0.35
	47	18×20	0.34
	56	16×25	0.38
	56	18×20	0.37
	68	16×30	0.45
	68	18×25	0.44
	82	18×30	0.52
	100	18×31.5	0.58

◆呼称方法/PART NUMBER

SBW M D×L
 Rated Voltage Series Capacitance Capacitance Tolerance Option Lead Forming Case Size

◆リプル電流補正係数/ MULTIPLIER FOR RIPPLE CURRENT

周波数 (Hz) Frequency	60(50)	120	500	1k	10k≦
係数 Coefficient	0.80	1.00	1.05	1.10	1.15

◆副記号/OPTION

EFC : PETスリーブ PET Sleeve

HXG series

105°C 3000 時間 高リップル 小形化品
Load Life : 105°C 3000 hours, High Ripple Current, Miniaturized



◆規格表 / SPECIFICATIONS

項目 Item	特性 Characteristics								
カテゴリ温度範囲 Category Temperature Range	-25~+105°C								
定格電圧範囲 Rated Voltage Range	160~250, 400~450Vdc								
静電容量許容差 Capacitance Tolerance	±20% (20°C, 120Hz)								
漏れ電流 Leakage Current (MAX)	$I=3\sqrt{CV}$ (定格電圧印加5分後) $I=3\sqrt{CV}$ (After 5 minutes application of rated voltage) I=漏れ電流 (μA) C=静電容量 (μF) V=定格電圧 (Vdc) Leakage Current Capacitance Rated Voltage								
損失角の正接 (tan δ) Dissipation Factor (MAX)	<table border="1"> <tr> <td>定格電圧 (Vdc) Rated Voltage</td> <td>160~450</td> <td>(20°C, 120Hz)</td> </tr> <tr> <td>tan δ</td> <td>0.20</td> <td></td> </tr> </table>	定格電圧 (Vdc) Rated Voltage	160~450	(20°C, 120Hz)	tan δ	0.20			
定格電圧 (Vdc) Rated Voltage	160~450	(20°C, 120Hz)							
tan δ	0.20								
耐久性 Endurance	<p>105°C 中で3000時間定格電圧(リップル重畳)印加後、下記項目を満足すること。 After applying rated voltage with rated ripple current for 3000 hours at 105°C, the capacitors shall meet the following requirements.</p> <table border="1"> <tr> <td>静電容量変化率 Capacitance Change</td> <td>初期値の ±20% 以内 Within ±20% of the initial value.</td> </tr> <tr> <td>損失角の正接 Dissipation Factor</td> <td>規格値の 200% 以下 Not more than 200% of the specified value.</td> </tr> <tr> <td>漏れ電流 Leakage Current</td> <td>規格値以下 Not more than the specified value.</td> </tr> </table>	静電容量変化率 Capacitance Change	初期値の ±20% 以内 Within ±20% of the initial value.	損失角の正接 Dissipation Factor	規格値の 200% 以下 Not more than 200% of the specified value.	漏れ電流 Leakage Current	規格値以下 Not more than the specified value.		
静電容量変化率 Capacitance Change	初期値の ±20% 以内 Within ±20% of the initial value.								
損失角の正接 Dissipation Factor	規格値の 200% 以下 Not more than 200% of the specified value.								
漏れ電流 Leakage Current	規格値以下 Not more than the specified value.								
低温特性 Low Temperature Stability (インピーダンス比) Impedance Ratio (MAX)	<table border="1"> <tr> <td>定格電圧 (Vdc) Rated Voltage</td> <td>160~250</td> <td>400~450</td> <td>(120Hz)</td> </tr> <tr> <td>Z(-25°C)/Z(+20°C)</td> <td>4</td> <td>8</td> <td></td> </tr> </table>	定格電圧 (Vdc) Rated Voltage	160~250	400~450	(120Hz)	Z(-25°C)/Z(+20°C)	4	8	
定格電圧 (Vdc) Rated Voltage	160~250	400~450	(120Hz)						
Z(-25°C)/Z(+20°C)	4	8							

◆呼称方法 / PART NUMBER

HXG M D x L
 定格電圧 Rated Voltage シリーズ名 Series 静電容量 Capacitance 静電容量許容差 Capacitance Tolerance 副記号 Option 端子記号 Terminal Code ケースサイズ Case Size

◆リップル電流補正係数 / MULTIPLIER FOR RIPPLE CURRENT

周波数 (Hz) Frequency	60 (50)	120 (100)	300	500	1k	10k ≤
係数 Coefficient	0.80	1.00	1.15	1.20	1.30	1.50
	0.80	1.00	1.15	1.20	1.25	1.40

◆副記号 / OPTION

EFC : PET スリーブ、底板なし
PET Sleeve without plate

◆端子記号 / Terminal Code

SN : 標準端子 Standard Terminal

その他の形状は端子形状一覧をご確認ください。
For other type, please refer to the list of terminal type.

◆寸法図/DIMENSIONS

●SN[4(3.5)mm]端子タイプ
SN[4(3.5)mm]terminal type

端子記号 : SN(錫メッキ)
Terminal code : SN(Tin plating)

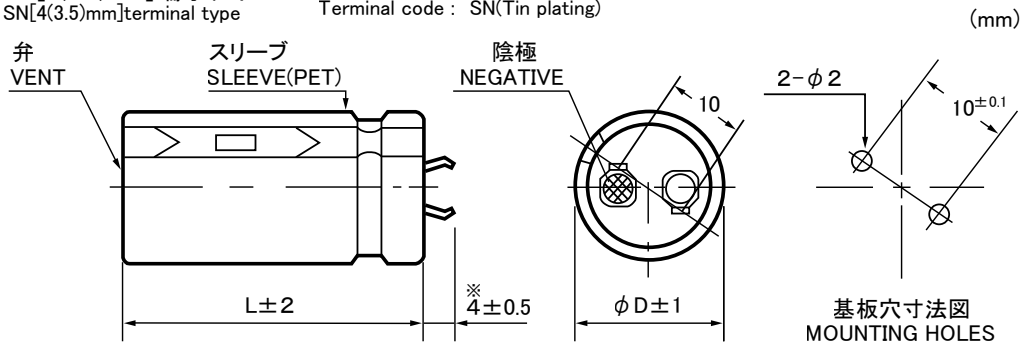

◆標準品一覧表/STANDARD SIZE

Cap.(μF)	160Vdc				180Vdc			
	φ 30		φ 35		φ 30		φ 35	
560					30x25	2.99		
680	30x25	3.18			30x30	3.45		
820	30x30	3.68			30x30	3.70	35x25	3.56
1000	30x35	4.20	35x25	3.72	30x35	4.22	35x30	4.14
1200	30x35	4.47	35x30	4.34	30x40	4.75	35x30	4.33
1500	30x45	5.35	35x35	4.99	30x45	5.37	35x35	4.97
1800	30x50	5.93	35x40	5.59	30x50	5.95	35x40	5.58
2200	30x55	6.58	35x45	6.23	30x60	6.85	35x50	6.57
2700			35x50	6.89			35x55	7.23
3300			35x60	7.92				

Cap.(μF)	200Vdc				220Vdc			
	φ 30		φ 35		φ 30		φ 35	
470					30x25	2.84		
560	30x25	3.01			30x30	3.26		
680	30x30	3.48			30x30	3.50	35x25	3.37
820	30x35	3.95	35x25	3.54	30x35	3.98	35x30	3.91
1000	30x35	4.24	35x30	4.13	30x40	4.50	35x35	4.46
1200	30x40	4.76	35x35	4.70	30x50	5.23	35x40	5.00
1500	30x50	5.62	35x40	5.33	30x55	5.87	35x45	5.62
1800	30x60	6.43	35x45	5.92			35x50	6.21
2200			35x55	6.87			35x60	7.13
2700			35x60	7.53				

Cap.(μF)	250Vdc			
	φ 30		φ 35	
390	30x25	2.67		
470	30x30	3.06		
560	30x30	3.28	35x25	3.18
680	30x35	3.73	35x30	3.69
820	30x40	4.19	35x35	4.19
1000	30x45	4.71	35x35	4.46
1200	30x50	5.23	35x40	5.00
1500	30x60	6.07	35x45	5.62
1800			35x55	6.48
2200			35x60	7.13

ケースサイズ Case Size φD×L(mm) → ↑
リップル電流 Ripple Current (A.r.m.s./120Hz,105°C) → ↑

◆標準品一覧表 / STANDARD SIZE

Cap.(μ F)	400Vdc									
	ϕ 20		ϕ 22		ϕ 25		ϕ 30		ϕ 35	
68	20x25	0.94								
82	20x25	1.01	22x25	1.07						
100	20x30	1.18	22x25	1.15						
120	20x35	1.35	22x30	1.34	25x25	1.31				
150	20x40	1.56	22x35	1.55	25x25	1.43				
180	20x45	1.76	22x40	1.76	25x30	1.65	30x25	1.68		
220			22x45	1.99	25x35	1.90	30x30	1.88		
270			22x50	2.24	25x40	2.16	30x30	2.01	35x25	2.12
330					25x50	2.55	30x35	2.31	35x30	2.33
390							30x40	2.59	35x35	2.52
470							30x50	3.04	35x40	2.85
560									35x45	3.18
680									35x50	3.47

Cap.(μ F)	420Vdc									
	ϕ 20		ϕ 22		ϕ 25		ϕ 30		ϕ 35	
68	20x25	0.92								
82	20x30	1.07	22x25	1.05						
100	20x35	1.23	22x30	1.22	25x25	1.20				
120	20x40	1.40	22x30	1.31	25x25	1.29				
150	20x45	1.60	22x35	1.52	25x30	1.51	30x25	1.49		
180	20x50	1.79	22x40	1.72	25x35	1.73	30x25	1.59		
220			22x50	2.03	25x40	1.97	30x30	1.85	35x25	1.74
270					25x45	2.22	30x35	2.12	35x30	2.04
330							30x40	2.41	35x30	2.16
390							30x45	2.68	35x35	2.45
470							30x50	2.98	35x45	2.92
560									35x50	3.23

Cap.(μ F)	450Vdc									
	ϕ 20		ϕ 22		ϕ 25		ϕ 30		ϕ 35	
56	20x25	0.85								
68	20x25	0.92	22x25	0.97						
82	20x30	1.07	22x25	1.05						
100	20x35	1.23	22x30	1.22	25x25	1.20				
120	20x40	1.40	22x35	1.39	25x25	1.29				
150	20x50	1.66	22x40	1.60	25x30	1.51	30x25	1.49		
180			22x45	1.80	25x35	1.73	30x30	1.72		
220					25x40	1.97	30x30	1.85	35x25	1.74
270					25x50	2.32	30x35	2.12	35x30	2.04
330							30x45	2.53	35x35	2.33
390							30x50	2.80	35x40	2.61
470									35x45	2.92
560									35x50	3.23

ケースサイズ Case Size ϕ D × L(mm) →
 リプル電流 Ripple Current (A.r.m.s./120Hz,105°C) →

HXH series

105°C 5000時間 標準品 -40°C対応
Load Life : 105°C 5000 hours, Standard, -40°C~+105°C

AEC-Q200



◆規格表 / SPECIFICATIONS

項目 Item	特性 Characteristics																
カテゴリ温度範囲 Category Temperature Range	-40~+105°C																
定格電圧範囲 Rated Voltage Range	400~450Vdc																
静電容量許容差 Capacitance Tolerance	±20% (20°C, 120Hz)																
漏れ電流 Leakage Current (MAX)	$I=3\sqrt{CV}$ (定格電圧印加5分後) $I=3\sqrt{CV}$ (After 5 minutes application of rated voltage) I=漏れ電流(μA) C=静電容量(μF) V=定格電圧(Vdc) Leakage Current Capacitance Rated Voltage																
損失角の正接 (tan δ) Dissipation Factor (MAX)	<table border="1"> <tr> <td>定格電圧 (Vdc) Rated Voltage</td> <td>400~450</td> <td rowspan="2">(20°C, 120Hz)</td> </tr> <tr> <td>tan δ</td> <td>0.20</td> </tr> </table>	定格電圧 (Vdc) Rated Voltage	400~450	(20°C, 120Hz)	tan δ	0.20											
定格電圧 (Vdc) Rated Voltage	400~450	(20°C, 120Hz)															
tan δ	0.20																
耐久性 Endurance	<p>105°C中で5000時間(又は3000時間)定格電圧(リップル重畳)印加後、下記項目を満足すること。 After applying rated voltage with rated ripple current for 5000hours(or 3000hours) at 105°C, the capacitors shall meet the following requirements.</p> <table border="1"> <tr> <td>静電容量変化率 Capacitance Change</td> <td>初期値の ±20% 以内 Within ±20% of the initial value.</td> </tr> <tr> <td>損失角の正接 Dissipation Factor</td> <td>規格値の 200% 以下 Not more than 200% of the specified value.</td> </tr> <tr> <td>漏れ電流 Leakage Current</td> <td>規格値以下 Not more than the specified value.</td> </tr> </table>	静電容量変化率 Capacitance Change	初期値の ±20% 以内 Within ±20% of the initial value.	損失角の正接 Dissipation Factor	規格値の 200% 以下 Not more than 200% of the specified value.	漏れ電流 Leakage Current	規格値以下 Not more than the specified value.										
静電容量変化率 Capacitance Change	初期値の ±20% 以内 Within ±20% of the initial value.																
損失角の正接 Dissipation Factor	規格値の 200% 以下 Not more than 200% of the specified value.																
漏れ電流 Leakage Current	規格値以下 Not more than the specified value.																
低温特性 Low Temperature Stability	<table border="1"> <tr> <td>インピーダンス比(MAX) Impedance Ratio (MAX) (120Hz)</td> <td>静電容量変化率 Capacitance Change (120Hz)</td> </tr> <tr> <td> <table border="1"> <tr> <td>定格電圧 (Vdc) Rated Voltage</td> <td>400~450</td> </tr> <tr> <td>Z(-25°C)/Z(+20°C)</td> <td>6</td> </tr> <tr> <td>Z(-40°C)/Z(+20°C)</td> <td>8</td> </tr> </table> </td> <td> <table border="1"> <tr> <td>定格電圧 (Vdc) Rated Voltage</td> <td>400~450</td> </tr> <tr> <td>{C(-25°C)-C(+20°C)}/C(+20°C)</td> <td>-20%~0%</td> </tr> <tr> <td>{C(-40°C)-C(+20°C)}/C(+20°C)</td> <td>-40%~0%</td> </tr> </table> </td> </tr> </table>	インピーダンス比(MAX) Impedance Ratio (MAX) (120Hz)	静電容量変化率 Capacitance Change (120Hz)	<table border="1"> <tr> <td>定格電圧 (Vdc) Rated Voltage</td> <td>400~450</td> </tr> <tr> <td>Z(-25°C)/Z(+20°C)</td> <td>6</td> </tr> <tr> <td>Z(-40°C)/Z(+20°C)</td> <td>8</td> </tr> </table>	定格電圧 (Vdc) Rated Voltage	400~450	Z(-25°C)/Z(+20°C)	6	Z(-40°C)/Z(+20°C)	8	<table border="1"> <tr> <td>定格電圧 (Vdc) Rated Voltage</td> <td>400~450</td> </tr> <tr> <td>{C(-25°C)-C(+20°C)}/C(+20°C)</td> <td>-20%~0%</td> </tr> <tr> <td>{C(-40°C)-C(+20°C)}/C(+20°C)</td> <td>-40%~0%</td> </tr> </table>	定格電圧 (Vdc) Rated Voltage	400~450	{C(-25°C)-C(+20°C)}/C(+20°C)	-20%~0%	{C(-40°C)-C(+20°C)}/C(+20°C)	-40%~0%
インピーダンス比(MAX) Impedance Ratio (MAX) (120Hz)	静電容量変化率 Capacitance Change (120Hz)																
<table border="1"> <tr> <td>定格電圧 (Vdc) Rated Voltage</td> <td>400~450</td> </tr> <tr> <td>Z(-25°C)/Z(+20°C)</td> <td>6</td> </tr> <tr> <td>Z(-40°C)/Z(+20°C)</td> <td>8</td> </tr> </table>	定格電圧 (Vdc) Rated Voltage	400~450	Z(-25°C)/Z(+20°C)	6	Z(-40°C)/Z(+20°C)	8	<table border="1"> <tr> <td>定格電圧 (Vdc) Rated Voltage</td> <td>400~450</td> </tr> <tr> <td>{C(-25°C)-C(+20°C)}/C(+20°C)</td> <td>-20%~0%</td> </tr> <tr> <td>{C(-40°C)-C(+20°C)}/C(+20°C)</td> <td>-40%~0%</td> </tr> </table>	定格電圧 (Vdc) Rated Voltage	400~450	{C(-25°C)-C(+20°C)}/C(+20°C)	-20%~0%	{C(-40°C)-C(+20°C)}/C(+20°C)	-40%~0%				
定格電圧 (Vdc) Rated Voltage	400~450																
Z(-25°C)/Z(+20°C)	6																
Z(-40°C)/Z(+20°C)	8																
定格電圧 (Vdc) Rated Voltage	400~450																
{C(-25°C)-C(+20°C)}/C(+20°C)	-20%~0%																
{C(-40°C)-C(+20°C)}/C(+20°C)	-40%~0%																

◆呼称方法 / PART NUMBER

□□□ HXH □□□□□ M EPA □□ D x L
 Rated Voltage Series Capacitance Capacitance Tolerance Option Terminal Code Case Size

◆リップル電流補正係数 / MULTIPLIER FOR RIPPLE CURRENT

周波数 (Hz) Frequency	60 (50)	120 (100)	300	500	1k	10k ≤
係数 Coefficient	0.80	1.00	1.15	1.20	1.25	1.40

◆副記号 / OPTION

EPA : PET スリーブ、底板なし

◆端子記号 / Terminal Code

SN : 標準端子 Standard Terminal

その他の形状は端子形状一覧をご確認ください。
For other type, please refer to the list of terminal type.

◆寸法図/DIMENSIONS

●SN[4mm]端子タイプ
SN[4mm]terminal type

端子記号 : SN(錫メッキ)
Terminal code : SN(Tin plating)

(mm)

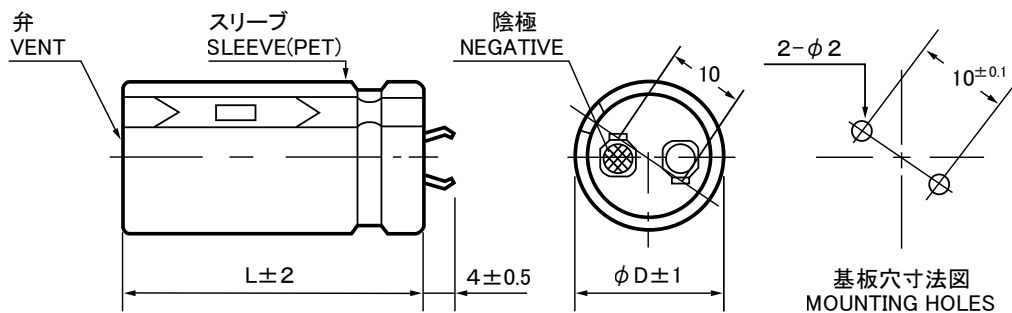

◆標準品一覧表/STANDARD SIZE

400Vdc									
Cap.(μ F)	ϕ 20			ϕ 22			ϕ 25		
	Endurance	5000hours	3000hours	Endurance	5000hours	3000hours	Endurance	5000hours	3000hours
100	20x25	0.82	1.16						
120	20x30	0.94	1.33	22x25	0.92	1.31			
150	20x35	1.10	1.55	22x30	1.08	1.54			
180	20x40	1.25	1.76	22x30	1.16	1.64	25x25	1.12	1.59
220	20x45	1.42	2.00	22x35	1.34	1.90	25x30	1.31	1.86
270	20x55	1.65	2.34	22x40	1.51	2.14	25x35	1.51	2.14
330	20x60	1.82	2.58	22x50	1.81	2.56	25x40	1.72	2.43
390				22x55	1.99	2.81	25x45	1.91	2.71
470							25x50	2.11	2.97
560							25x60	2.45	3.45

400Vdc						
Cap.(μ F)	ϕ 30			ϕ 35		
	Endurance	5000hours	3000hours	Endurance	5000hours	3000hours
220	30x25	1.33	1.89			
270	30x30	1.56	2.20			
330	30x30	1.66	2.34	35x25	1.55	2.20
390	30x35	1.90	2.68	35x30	1.83	2.59
470	30x40	2.14	3.03	35x35	2.09	2.96
560	30x45	2.39	3.37	35x35	2.15	3.04
680	30x55	2.78	3.94	35x45	2.63	3.72
820				35x50	2.91	4.12
1000				35x60	3.36	4.75

420Vdc									
Cap.(μ F)	ϕ 20			ϕ 22			ϕ 25		
	Endurance	5000hours	3000hours	Endurance	5000hours	3000hours	Endurance	5000hours	3000hours
82	20x25	0.75	1.07						
100	20x30	0.87	1.24						
120	20x30	0.95	1.34	22x25	0.93	1.31			
150	20x35	1.10	1.56	22x30	1.09	1.54	25x25	1.06	1.50
180	20x40	1.25	1.76	22x35	1.24	1.76	25x30	1.22	1.73
220	20x50	1.47	2.08	22x40	1.42	2.01	25x30	1.31	1.86
270	20x55	1.64	2.33	22x45	1.61	2.28	25x35	1.51	2.14
330				22x50	1.78	2.52	25x40	1.70	2.41
390				22x60	2.07	2.93	25x45	1.89	2.67
470							25x55	2.23	3.13

ケースサイズ Case Size ϕ D x L(mm) \rightarrow ↑
リップル電流 Ripple Current (A.r.m.s./120Hz,105°C) \rightarrow ↑

◆標準品一覧表／STANDARD SIZE

Cap.(μ F)	420Vdc					
	ϕ 30			ϕ 35		
	Endurance	5000hours	3000hours	Endurance	5000hours	3000hours
220	30x25	1.33	1.89			
270	30x30	1.56	2.21	35x25	1.49	2.11
330	30x35	1.79	2.53	35x30	1.74	2.47
390	30x35	1.87	2.65	35x30	1.82	2.57
470	30x45	2.25	3.19	35x35	2.09	2.95
560	30x50	2.50	3.54	35x40	2.35	3.32
680	30x60	2.89	4.08	35x45	2.62	3.70
820				35x55	3.05	4.32
1000				35x60	3.32	4.69

Cap.(μ F)	450Vdc								
	ϕ 20			ϕ 22			ϕ 25		
	Endurance	5000hours	3000hours	Endurance	5000hours	3000hours	Endurance	5000hours	3000hours
82	20x25	0.76	1.07						
100	20x30	0.88	1.25	22x25	0.86	1.22			
120	20x35	1.00	1.42	22x30	1.00	1.41			
150	20x40	1.16	1.65	22x30	1.09	1.54	25x25	1.06	1.50
180	20x45	1.31	1.85	22x35	1.25	1.77	25x30	1.23	1.74
220	20x50	1.46	2.06	22x40	1.41	2.00	25x35	1.41	1.99
270	20x60	1.70	2.41	22x50	1.68	2.38	25x40	1.60	2.27
330				22x55	1.86	2.63	25x45	1.81	2.56
390							25x50	1.99	2.80
470							25x60	2.31	3.26

Cap.(μ F)	450Vdc					
	ϕ 30			ϕ 35		
	Endurance	5000hours	3000hours	Endurance	5000hours	3000hours
180	30x25	1.24	1.76			
220	30x30	1.45	2.05			
270	30x30	1.56	2.21	35x25	1.48	2.09
330	30x35	1.79	2.54	35x30	1.74	2.46
390	30x40	2.01	2.85	35x35	1.98	2.80
470	30x45	2.25	3.16	35x40	2.23	3.16
560	30x55	2.60	3.69	35x45	2.49	3.51
680	30x60	2.84	4.02	35x50	2.76	3.90
820				35x60	3.17	4.48

ケースサイズ Case Size ϕ D x L(mm) \longrightarrow \uparrow \uparrow \uparrow
 リプル電流 Ripple Current (A.r.m.s./120Hz,105°C) \longleftarrow

HXK series

105°C 5000時間 小形化品 -40°C対応
Load Life : 105°C 5000 hours, Miniaturized, -40°C~+105°C

AEC-Q200



◆規格表/SPECIFICATIONS

項目 Item	特性 Characteristics																
カテゴリ温度範囲 Category Temperature Range	-40~+105°C																
定格電圧範囲 Rated Voltage Range	400~450Vdc																
静電容量許容差 Capacitance Tolerance	±20%(20°C, 120Hz)																
漏れ電流 Leakage Current (MAX)	$I=3\sqrt{CV}$ (定格電圧印加5分後) $I=3\sqrt{CV}$ (After 5 minutes application of rated voltage) I=漏れ電流(μA) C=静電容量(μF) V=定格電圧(Vdc) Leakage Current Capacitance Rated Voltage																
損失角の正接(tan δ) Dissipation Factor (MAX)	<table border="1"> <tr> <td>定格電圧(Vdc) Rated Voltage</td> <td>400~450</td> <td rowspan="2">(20°C, 120Hz)</td> </tr> <tr> <td>tan δ</td> <td>0.20</td> </tr> </table>	定格電圧(Vdc) Rated Voltage	400~450	(20°C, 120Hz)	tan δ	0.20											
定格電圧(Vdc) Rated Voltage	400~450	(20°C, 120Hz)															
tan δ	0.20																
耐久性 Endurance	<p>105°C中で5000時間(又は3000時間)定格電圧(リップル重畳)印加後、下記項目を満足すること。 After applying rated voltage with rated ripple current for 5000hours(or 3000hours) at 105°C, the capacitors shall meet the following requirements.</p> <table border="1"> <tr> <td>静電容量変化率 Capacitance Change</td> <td>初期値の ±20% 以内 Within ±20% of the initial value.</td> </tr> <tr> <td>損失角の正接 Dissipation Factor</td> <td>規格値の 200% 以下 Not more than 200% of the specified value.</td> </tr> <tr> <td>漏れ電流 Leakage Current</td> <td>規格値以下 Not more than the specified value.</td> </tr> </table>	静電容量変化率 Capacitance Change	初期値の ±20% 以内 Within ±20% of the initial value.	損失角の正接 Dissipation Factor	規格値の 200% 以下 Not more than 200% of the specified value.	漏れ電流 Leakage Current	規格値以下 Not more than the specified value.										
静電容量変化率 Capacitance Change	初期値の ±20% 以内 Within ±20% of the initial value.																
損失角の正接 Dissipation Factor	規格値の 200% 以下 Not more than 200% of the specified value.																
漏れ電流 Leakage Current	規格値以下 Not more than the specified value.																
低温特性 Low Temperature Stability	<table border="1"> <tr> <td>インピーダンス比(MAX) Impedance Ratio (MAX) (120Hz)</td> <td>静電容量変化率 Capacitance Change (120Hz)</td> </tr> <tr> <td> <table border="1"> <tr> <td>定格電圧(Vdc) Rated Voltage</td> <td>400~450</td> </tr> <tr> <td>Z(-25°C)/Z(+20°C)</td> <td>6</td> </tr> <tr> <td>Z(-40°C)/Z(+20°C)</td> <td>8</td> </tr> </table> </td> <td> <table border="1"> <tr> <td>定格電圧(Vdc) Rated Voltage</td> <td>400~450</td> </tr> <tr> <td>{C(-25°C)-C(+20°C)}/C(+20°C)</td> <td>-20%~0%</td> </tr> <tr> <td>{C(-40°C)-C(+20°C)}/C(+20°C)</td> <td>-40%~0%</td> </tr> </table> </td> </tr> </table>	インピーダンス比(MAX) Impedance Ratio (MAX) (120Hz)	静電容量変化率 Capacitance Change (120Hz)	<table border="1"> <tr> <td>定格電圧(Vdc) Rated Voltage</td> <td>400~450</td> </tr> <tr> <td>Z(-25°C)/Z(+20°C)</td> <td>6</td> </tr> <tr> <td>Z(-40°C)/Z(+20°C)</td> <td>8</td> </tr> </table>	定格電圧(Vdc) Rated Voltage	400~450	Z(-25°C)/Z(+20°C)	6	Z(-40°C)/Z(+20°C)	8	<table border="1"> <tr> <td>定格電圧(Vdc) Rated Voltage</td> <td>400~450</td> </tr> <tr> <td>{C(-25°C)-C(+20°C)}/C(+20°C)</td> <td>-20%~0%</td> </tr> <tr> <td>{C(-40°C)-C(+20°C)}/C(+20°C)</td> <td>-40%~0%</td> </tr> </table>	定格電圧(Vdc) Rated Voltage	400~450	{C(-25°C)-C(+20°C)}/C(+20°C)	-20%~0%	{C(-40°C)-C(+20°C)}/C(+20°C)	-40%~0%
インピーダンス比(MAX) Impedance Ratio (MAX) (120Hz)	静電容量変化率 Capacitance Change (120Hz)																
<table border="1"> <tr> <td>定格電圧(Vdc) Rated Voltage</td> <td>400~450</td> </tr> <tr> <td>Z(-25°C)/Z(+20°C)</td> <td>6</td> </tr> <tr> <td>Z(-40°C)/Z(+20°C)</td> <td>8</td> </tr> </table>	定格電圧(Vdc) Rated Voltage	400~450	Z(-25°C)/Z(+20°C)	6	Z(-40°C)/Z(+20°C)	8	<table border="1"> <tr> <td>定格電圧(Vdc) Rated Voltage</td> <td>400~450</td> </tr> <tr> <td>{C(-25°C)-C(+20°C)}/C(+20°C)</td> <td>-20%~0%</td> </tr> <tr> <td>{C(-40°C)-C(+20°C)}/C(+20°C)</td> <td>-40%~0%</td> </tr> </table>	定格電圧(Vdc) Rated Voltage	400~450	{C(-25°C)-C(+20°C)}/C(+20°C)	-20%~0%	{C(-40°C)-C(+20°C)}/C(+20°C)	-40%~0%				
定格電圧(Vdc) Rated Voltage	400~450																
Z(-25°C)/Z(+20°C)	6																
Z(-40°C)/Z(+20°C)	8																
定格電圧(Vdc) Rated Voltage	400~450																
{C(-25°C)-C(+20°C)}/C(+20°C)	-20%~0%																
{C(-40°C)-C(+20°C)}/C(+20°C)	-40%~0%																

◆呼称方法/PART NUMBER

□□□ HXK □□□□□ M EPA □□ D x L
 Rated Voltage Series Capacitance Capacitance Tolerance Option Terminal Code Case Size

◆リップル電流補正係数/
MULTIPLIER FOR RIPPLE CURRENT

周波数(Hz) Frequency	60 (50)	120 (100)	300	500	1k	10k ≤	
係数 Coefficient	400~450Vdc	0.80	1.00	1.15	1.20	1.25	1.40

◆副記号/OPTION

EPA : PET スリーブ、底板なし

◆端子記号/Terminal Code

SN : 標準端子 Standard Terminal

その他の形状は端子形状一覧をご確認ください。
For other type, please refer to the list of terminal type.

◆寸法図/DIMENSIONS

●SN[4mm]端子タイプ
SN[4mm]terminal type

端子記号 : SN(錫メッキ)
Terminal code : SN(Tin plating)

(mm)

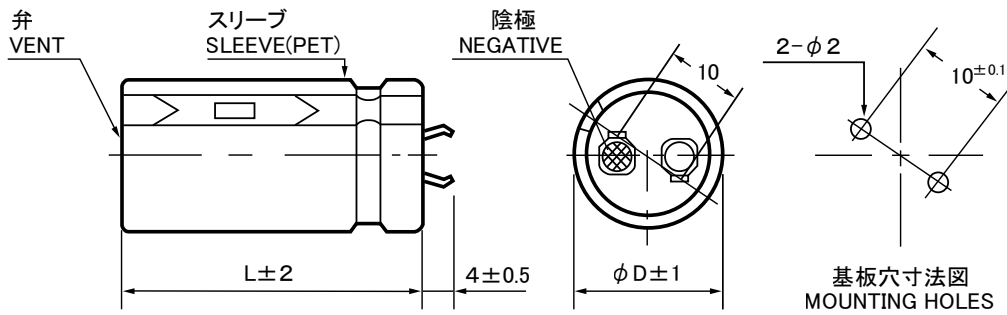

◆標準品一覧表/STANDARD SIZE

400Vdc									
Cap.(μ F)	ϕ 20			ϕ 22			ϕ 25		
	Endurance	5000hours	3000hours	Endurance	5000hours	3000hours	Endurance	5000hours	3000hours
100	20x25	0.81	1.15						
120	20x30	0.94	1.33						
150	20x35	1.09	1.54	22x25	0.99	1.41			
180	20x35	1.16	1.65	22x30	1.16	1.65	25x25	1.12	1.59
220	20x45	1.40	1.99	22x35	1.34	1.90	25x30	1.31	1.86
270	20x50	1.59	2.26	22x40	1.53	2.16	25x35	1.51	2.14
330	20x60	1.84	2.61	22x45	1.71	2.43	25x35	1.59	2.25
390				22x55	1.99	2.82	25x40	1.79	2.53
470				22x60	2.19	3.09	25x50	2.13	3.02
560							25x55	2.34	3.29

400Vdc						
Cap.(μ F)	ϕ 30			ϕ 35		
	Endurance	5000hours	3000hours	Endurance	5000hours	3000hours
270	30x25	1.41	1.99			
330	30x30	1.67	2.36	35x25	1.57	2.23
390	30x35	1.89	2.68	35x30	1.84	2.60
470	30x40	2.14	3.03	35x30	1.91	2.69
560	30x45	2.39	3.38	35x35	2.20	3.10
680	30x50	2.67	3.74	35x40	2.48	3.49
820	30x60	3.07	4.34	35x45	2.75	3.86
1000				35x55	3.23	4.56

420Vdc									
Cap.(μ F)	ϕ 20			ϕ 22			ϕ 25		
	Endurance	5000hours	3000hours	Endurance	5000hours	3000hours	Endurance	5000hours	3000hours
100	20x25	0.82	1.15						
120	20x30	0.94	1.33	22x25	0.92	1.31			
150	20x35	1.10	1.55	22x30	1.08	1.53			
180	20x40	1.24	1.76	22x30	1.16	1.64	25x25	1.13	1.59
220	20x45	1.41	2.00	22x35	1.34	1.89	25x30	1.31	1.86
270	20x55	1.65	2.34	22x40	1.51	2.13	25x35	1.51	2.14
330	20x60	1.82	2.57	22x50	1.81	2.56	25x40	1.72	2.43
390				22x55	1.98	2.81	25x45	1.92	2.71
470							25x50	2.11	2.99
560							25x60	2.45	3.45

ケースサイズ Case Size ϕ D x L(mm) \rightarrow ↑
 リプル電流 Ripple Current (A.r.m.s./120Hz,105°C) \rightarrow ↑

◆標準品一覧表／STANDARD SIZE

Cap.(μ F)	420Vdc					
	ϕ 30			ϕ 35		
	Endurance	5000hours	3000hours	Endurance	5000hours	3000hours
220	30x25	1.33	1.89			
270	30x30	1.56	2.20			
330	30x30	1.66	2.34	35x25	1.56	2.20
390	30x35	1.89	2.68	35x30	1.83	2.59
470	30x40	2.14	3.03	35x35	2.10	2.97
560	30x45	2.39	3.37	35x40	2.36	3.34
680	30x55	2.78	3.94	35x45	2.64	3.73
820				35x50	2.92	4.13
1000				35x60	3.37	4.76

Cap.(μ F)	450Vdc								
	ϕ 20			ϕ 22			ϕ 25		
	Endurance	5000hours	3000hours	Endurance	5000hours	3000hours	Endurance	5000hours	3000hours
82	20x25	0.75	1.07						
100	20x30	0.87	1.24						
120	20x30	0.94	1.33	22x25	0.93	1.31			
150	20x35	1.09	1.54	22x30	1.09	1.54	25x25	1.06	1.50
180	20x40	1.23	1.74	22x35	1.24	1.76	25x30	1.22	1.73
220	20x50	1.47	2.08	22x40	1.42	2.01	25x30	1.30	1.84
270	20x60	1.71	2.43	22x45	1.61	2.28	25x35	1.49	2.12
330				22x55	1.88	2.66	25x45	1.81	2.56
390				22x60	2.05	2.90	25x50	2.01	2.84
470							25x55	2.21	3.10

Cap.(μ F)	450Vdc					
	ϕ 30			ϕ 35		
	Endurance	5000hours	3000hours	Endurance	5000hours	3000hours
220	30x25	1.33	1.88			
270	30x30	1.56	2.21	35x25	1.49	2.10
330	30x35	1.79	2.54	35x30	1.75	2.47
390	30x40	2.01	2.85	35x30	1.82	2.56
470	30x45	2.26	3.20	35x35	2.09	2.94
560	30x50	2.51	3.54	35x40	2.35	3.32
680	30x60	2.89	4.08	35x45	2.60	3.68
820				35x55	3.05	4.31

ケースサイズ Case Size ϕ D×L(mm) \rightarrow \uparrow \uparrow \uparrow
 リプル電流 Ripple Current (A.r.m.s./120Hz,105°C) \rightarrow \uparrow \uparrow \uparrow

MXG series

105°C 3000 時間 標準品
Load Life : 105°C 3000 hours, Standard



◆規格表 / SPECIFICATIONS

項目 Item	特性 Characteristics																							
カテゴリ温度範囲 Category Temperature Range	-40~+105°C	-25~+105°C																						
定格電圧範囲 Rated Voltage Range	10~250Vdc	315~500Vdc																						
静電容量許容差 Capacitance Tolerance	±20% (20°C, 120Hz)																							
漏れ電流 Leakage Current (MAX)	$I=3\sqrt{CV}$ (定格電圧印加5分後) $I=3\sqrt{CV}$ (After 5 minutes application of rated voltage) I=漏れ電流(μA) C=静電容量(μF) V=定格電圧(Vdc) Leakage Current Capacitance Rated Voltage																							
損失角の正接 (tan δ) Dissipation Factor (MAX)	<table border="1"> <thead> <tr> <th>定格電圧 (Vdc) Rated Voltage</th> <th>10</th> <th>16</th> <th>25</th> <th>35</th> <th>50</th> <th>63</th> <th>80~100</th> <th>160~450</th> <th>500</th> <th>(20°C, 120Hz)</th> </tr> </thead> <tbody> <tr> <td>tan δ</td> <td>0.55</td> <td>0.50</td> <td>0.45</td> <td>0.40</td> <td>0.35</td> <td>0.30</td> <td>0.25</td> <td>0.20</td> <td>0.25</td> <td></td> </tr> </tbody> </table>		定格電圧 (Vdc) Rated Voltage	10	16	25	35	50	63	80~100	160~450	500	(20°C, 120Hz)	tan δ	0.55	0.50	0.45	0.40	0.35	0.30	0.25	0.20	0.25	
定格電圧 (Vdc) Rated Voltage	10	16	25	35	50	63	80~100	160~450	500	(20°C, 120Hz)														
tan δ	0.55	0.50	0.45	0.40	0.35	0.30	0.25	0.20	0.25															
耐久性 Endurance	105°C中で3000時間定格電圧(リップル重畳)印加後、下記項目を満足すること。 After applying rated voltage with rated ripple current for 3000 hours at 105°C, the capacitors shall meet the following requirements.																							
	<table border="1"> <tbody> <tr> <td>静電容量変化率 Capacitance Change</td> <td>初期値の ±20% 以内 Within ±20% of the initial value.</td> </tr> <tr> <td>損失角の正接 Dissipation Factor</td> <td>規格値の 200% 以下 Not more than 200% of the specified value.</td> </tr> <tr> <td>漏れ電流 Leakage Current</td> <td>規格値以下 Not more than the specified value.</td> </tr> </tbody> </table>		静電容量変化率 Capacitance Change	初期値の ±20% 以内 Within ±20% of the initial value.	損失角の正接 Dissipation Factor	規格値の 200% 以下 Not more than 200% of the specified value.	漏れ電流 Leakage Current	規格値以下 Not more than the specified value.																
静電容量変化率 Capacitance Change	初期値の ±20% 以内 Within ±20% of the initial value.																							
損失角の正接 Dissipation Factor	規格値の 200% 以下 Not more than 200% of the specified value.																							
漏れ電流 Leakage Current	規格値以下 Not more than the specified value.																							
低温特性 Low Temperature Stability (インピーダンス比) Impedance Ratio (MAX)	<table border="1"> <thead> <tr> <th>定格電圧 (Vdc) Rated Voltage</th> <th>10~100</th> <th>160~250</th> <th>315~450</th> <th>500</th> <th>(120Hz)</th> </tr> </thead> <tbody> <tr> <td>Z(-25°C)/Z(+20°C)</td> <td>3</td> <td>4</td> <td>8</td> <td>10</td> <td></td> </tr> <tr> <td>Z(-40°C)/Z(+20°C)</td> <td>12</td> <td>15</td> <td>-</td> <td>-</td> <td></td> </tr> </tbody> </table>		定格電圧 (Vdc) Rated Voltage	10~100	160~250	315~450	500	(120Hz)	Z(-25°C)/Z(+20°C)	3	4	8	10		Z(-40°C)/Z(+20°C)	12	15	-	-					
定格電圧 (Vdc) Rated Voltage	10~100	160~250	315~450	500	(120Hz)																			
Z(-25°C)/Z(+20°C)	3	4	8	10																				
Z(-40°C)/Z(+20°C)	12	15	-	-																				

◆呼称方法 / PART NUMBER

□□□ MXG □□□□□ M □□□ □□ D x L
 Rated Voltage Series Capacitance Capacitance Tolerance Option Terminal Code Case Size

◆リップル電流補正係数 /

MULTIPLIER FOR RIPPLE CURRENT

周波数 (Hz) Frequency	60 (50)	120 (100)	300	500	1k	10k ≤
10~100Vdc	0.90	1.00	1.03	1.05	1.10	1.15
160~250Vdc	0.80	1.00	1.15	1.20	1.30	1.50
315~500Vdc	0.80	1.00	1.15	1.20	1.25	1.40

◆副記号 / OPTION

EFC : PET スリーブ、底板なし
PET Sleeve without plate

◆端子記号 / Terminal Code

SN : 標準端子 Standard Terminal

その他の形状は端子形状一覧をご確認ください。
For other type, please refer to the list of terminal type.

◆寸法図／DIMENSIONS

●SN[4(3.5)mm]端子タイプ 端子記号 : SN(錫メッキ)
SN[4(3.5)mm]terminal type Terminal code : SN(Tin plating)

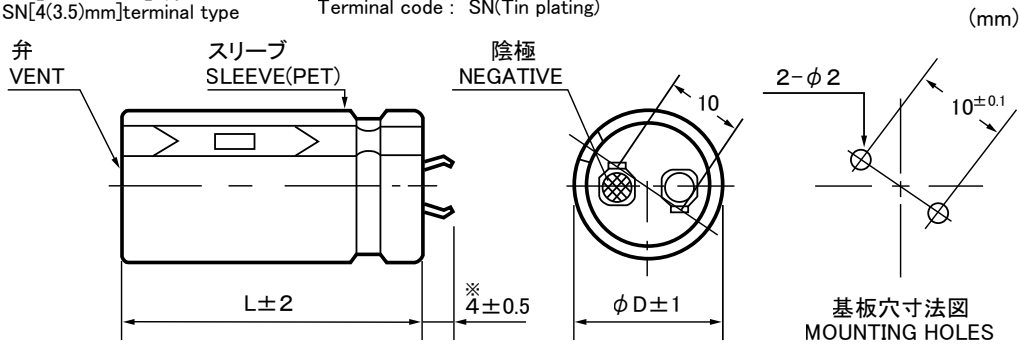

◆標準品一覧表／STANDARD SIZE

Cap. (μ F)	10Vdc					16Vdc									
	ϕ 20	ϕ 22	ϕ 25	ϕ 30	ϕ 35	ϕ 20	ϕ 22	ϕ 25	ϕ 30	ϕ 35					
6800	20x25	1.31				20x25	1.80								
8200	20x30	1.59				20x30	2.08	22x25	2.08						
10000	20x30	1.88	22x25	1.77		20x35	2.15	22x30	2.15						
12000	20x35	2.18	22x30	2.10	25x25	1.94	20x40	2.31	22x30	2.31					
15000	20x40	2.27	22x35	2.23	25x30	2.10		22x35	2.68	25x30	2.68				
18000			22x40	2.41	25x30	2.34	30x25	2.25							
22000			22x45	2.58	25x35	2.54	30x30	2.50							
27000			22x50	3.17	25x40	3.07	30x30	2.95							
33000					25x45	3.39	30x35	3.33	35x30	3.21					
39000							30x40	3.70	35x35	3.68					
47000									25x50	4.81	30x40	4.81	35x35	4.81	
56000											30x45	5.53	35x40	5.53	
68000												30x50	6.00	35x45	6.00

Cap. (μ F)	25Vdc					35Vdc									
	ϕ 20	ϕ 22	ϕ 25	ϕ 30	ϕ 35	ϕ 20	ϕ 22	ϕ 25	ϕ 30	ϕ 35					
2700						20x25	1.29								
3300						20x30	1.57								
3900						20x30	1.78	22x25	1.78						
4700	20x25	1.65				20x35	2.02	22x30	2.02						
5600	20x30	1.85	22x25	1.85		20x40	2.13	22x35	2.13	25x25	2.13				
6800	20x35	2.11	22x30	2.11				22x40	2.41	25x30	2.41				
8200	20x40	2.34	22x30	2.34	25x25	2.34		22x45	2.85	25x35	2.85	30x25	2.85		
10000			22x35	2.65	25x30	2.65		22x50	3.05	25x40	3.05	30x30	3.05		
12000			22x40	2.81	25x30	2.81	30x25	2.81		25x45	3.37	30x35	3.37	35x30	3.37
15000			22x45	3.13	25x35	3.13	30x30	3.13		25x50	3.72	30x40	3.72	35x35	3.72
18000					25x40	3.56	30x30	3.56				30x45	4.37	35x35	4.37
22000					25x50	4.04	30x35	4.04	35x30	4.04		30x50	4.92	35x40	4.92
27000							30x40	4.74	35x35	4.74				35x50	5.30
33000									30x50	5.50					
39000											35x45	5.80			
47000													35x50	6.30	

Cap. (μ F)	50Vdc					63Vdc												
	ϕ 20	ϕ 22	ϕ 25	ϕ 30	ϕ 35	ϕ 20	ϕ 22	ϕ 25	ϕ 30	ϕ 35								
1500						20x25	1.47											
1800						20x30	1.58											
2200	20x25	1.60				20x35	1.82											
2700	20x30	1.73	22x25	1.73				22x30	2.11	25x25	2.11							
3300	20x35	1.97	22x30	1.97				22x35	2.33	25x30	2.33							
3900	20x40	2.22	22x35	2.22	25x25	2.22		22x40	2.55	25x30	2.55	30x25	2.55					
4700	20x45	2.43	22x40	2.43	25x30	2.43		22x45	2.97	25x35	2.97	30x30	2.97					
5600			22x45	2.75	25x35	2.75	30x25	2.75		25x40	3.22	30x30	3.22	35x25	3.22			
6800			22x50	3.30	25x40	3.30	30x30	3.30	35x25	3.30		25x45	3.65	30x35	3.65	35x30	3.65	
8200					25x45	3.60	30x35	3.60	35x30	3.60				30x40	4.04	35x35	4.04	
10000					25x50	4.05	30x40	4.05	35x30	4.05				30x45	4.48	35x40	4.48	
12000							30x45	4.56	35x35	4.56					35x45	4.75		
15000							30x50	4.77	35x40	4.77					35x50	5.25		

ケースサイズ Case Size $\phi D \times L$ (mm) \rightarrow
リップル電流 Ripple Current (A.r.m.s./120Hz,105°C) \rightarrow

◆標準品一覧表 / STANDARD SIZE

Cap. (μ F)	80Vdc					100Vdc											
	ϕ 20	ϕ 22	ϕ 25	ϕ 30	ϕ 35	ϕ 20	ϕ 22	ϕ 25	ϕ 30	ϕ 35							
680						20x25	1.15										
820						20x30	1.32	22x25	1.32								
1000	20x25	1.24				20x30	1.47	22x30	1.47								
1200	20x30	1.44	22x25	1.44		20x35	1.69	22x30	1.69	25x25	1.69						
1500	20x30	1.59	22x30	1.59				22x35	1.98	25x30	1.98						
1800	20x35	1.79	22x30	1.79	25x25	1.79			22x40	2.23	25x35	2.23	30x25	2.23			
2200	20x40	2.03	22x35	2.03	25x30	2.03				25x40	2.55	30x30	2.55	35x25	2.55		
2700			22x40	2.39	25x35	2.39	30x25	2.39			25x45	2.89	30x35	2.89	35x30	2.89	
3300			22x50	2.64	25x40	2.64	30x30	2.64	35x25	2.64		25x50	3.30	30x40	3.30	35x35	3.30
3900					25x45	2.97	30x30	2.97	35x30	2.97				30x45	3.67	35x35	3.67
4700					25x50	3.38	30x35	3.38	35x30	3.38				30x50	3.80	35x40	3.80
5600							30x40	3.80	35x35	3.80						35x45	4.05
6800							30x50	4.10	35x40	4.10							
8200									35x45	4.30							

Cap. (μ F)	160Vdc					180Vdc													
	ϕ 20	ϕ 22	ϕ 25	ϕ 30	ϕ 35	ϕ 20	ϕ 22	ϕ 25	ϕ 30	ϕ 35									
330	20x25	1.32				20x25	1.32												
390	20x25	1.39				20x30	1.53	22x25	1.43										
470	20x30	1.62	22x25	1.51		20x35	1.75	22x30	1.67										
560	20x35	1.85	22x30	1.75		20x40	1.98	22x30	1.75	25x25	1.59								
680	20x40	2.09	22x30	1.83	25x25	1.70	20x45	2.22	22x35	2.01	25x30	1.86							
820	20x50	2.47	22x35	2.10	25x30	2.00			22x40	2.27	25x35	2.14	30x25	2.00					
1000			22x40	2.37	25x35	2.20	30x25	2.20		22x50	2.68	25x40	2.40	30x30	2.20	35x25	2.20		
1200			22x55	2.98	25x40	2.50	30x30	2.30	35x25	2.30		22x60	3.09	25x45	2.67	30x35	2.30	35x30	2.30
1500					25x45	2.80	30x35	2.50	35x30	2.50			25x50	2.99	30x40	2.54	35x30	2.50	
1800					25x60	3.43	30x40	2.70	35x35	2.70					30x45	2.79	35x35	2.70	
2200							30x45	2.90	35x40	2.90					30x50	3.12	35x40	2.90	
2700							30x60	3.58	35x45	3.10						35x50	3.10		
3300									35x55	3.24						35x60	3.44		

Cap. (μ F)	200Vdc					220Vdc											
	ϕ 20	ϕ 22	ϕ 25	ϕ 30	ϕ 35	ϕ 20	ϕ 22	ϕ 25	ϕ 30	ϕ 35							
220						20x25	1.17										
270	20x25	1.25				20x30	1.36	22x25	1.29								
330	20x30	1.46	22x25	1.37		20x30	1.46	22x25	1.37								
390	20x30	1.54	22x25	1.44		20x35	1.66	22x30	1.58	25x25	1.46						
470	20x35	1.76	22x30	1.67	25x25	1.53	20x40	1.87	22x35	1.81	25x25	1.53					
560	20x40	1.98	22x35	1.90	25x25	1.60	20x45	2.09	22x40	2.04	25x30	1.79	30x25	1.61			
680	20x50	2.34	22x40	2.15	25x30	1.85	30x25	1.75		22x45	2.29	25x35	2.05	30x25	1.78		
820			22x45	2.41	25x35	2.12	30x25	2.04		22x50	2.54	25x40	2.31	30x30	1.93	35x25	1.93
1000			22x55	2.84	25x45	2.58	30x30	2.30			25x50	2.72	30x35	2.33	35x30	2.33	
1200					25x50	2.84	30x35	2.65	35x30	2.65		25x55	2.96	30x40	2.50	35x35	2.50
1500					25x60	3.28	30x45	2.80	35x35	2.80				30x50	2.92	35x40	2.76
1800							30x50	3.08	35x40	3.08				30x60	3.38	35x45	3.11
2200							30x60	3.45	35x45	3.48						35x55	3.67
2700									35x55	4.05							

Cap. (μ F)	250Vdc					315Vdc											
	ϕ 20	ϕ 22	ϕ 25	ϕ 30	ϕ 35	ϕ 20	ϕ 22	ϕ 25	ϕ 30	ϕ 35							
120						20x25	0.86										
150						20x30	1.00	22x25	0.98								
180						20x35	1.14	22x30	1.13								
220	20x25	1.17				20x40	1.30	22x30	1.22	25x25	1.17						
270	20x30	1.36	22x25	1.30		20x45	1.48	22x35	1.40	25x30	1.37						
330	20x35	1.57	22x30	1.51	25x25	1.41	20x50	1.67	22x40	1.59	25x35	1.56	30x25	1.38			
390	20x40	1.76	22x35	1.71	25x25	1.47			22x50	1.84	25x35	1.65	30x30	1.60	35x25	1.44	
470	20x45	1.98	22x40	1.94	25x30	1.71	30x25	1.57		22x55	2.05	25x45	1.96	30x35	1.83	35x30	1.71
560			22x45	2.16	25x35	1.95	30x25	1.60			25x50	2.17	30x35	1.89	35x30	1.72	
680			22x50	2.40	25x40	2.20	30x30	1.87	35x25	1.70		25x55	2.41	30x40	2.12	35x35	1.98
820			22x60	2.77	25x45	2.45	30x35	2.14	35x30	2.00				30x50	2.51	35x40	2.22
1000					25x55	2.87	30x40	2.40	35x35	2.20				30x55	2.75	35x45	2.45
1200							30x45	2.65	35x35	2.30						35x50	2.67
1500							30x55	3.12	35x45	2.67						35x60	3.08
1800									35x50	2.89							
2200									35x60	3.32							

ケースサイズ Case Size $\phi D \times L$ (mm) \rightarrow
 リプル電流 Ripple Current (A.r.m.s./120Hz,105°C) \rightarrow

◆標準品一覧表 / STANDARD SIZE

Cap. (μ F)	350Vdc										385Vdc					
	ϕ 20		ϕ 22		ϕ 25		ϕ 30		ϕ 35		ϕ 20	ϕ 22		ϕ 25	ϕ 30	ϕ 35
100	20x25	0.81									20x25	0.81				
120	20x30	0.93	22x25	0.91							20x30	0.94	22x25	0.91		
150	20x35	1.08	22x30	1.06							20x35	1.08	22x30	1.07		
180	20x40	1.22	22x30	1.14	25x25	1.10					20x40	1.22	22x35	1.21	25x25	1.11
220	20x45	1.38	22x35	1.31	25x30	1.28					20x45	1.39	22x40	1.38	25x30	1.29
270	20x50	1.56	22x45	1.55	25x35	1.47	30x25	1.31					22x45	1.56	25x35	1.47
330			22x50	1.75	25x40	1.67	30x30	1.53	35x25	1.39			22x55	1.81	25x40	1.67
390			22x55	1.93	25x45	1.86	30x35	1.74	35x30	1.63			22x60	2.00	25x50	1.94
470					25x50	2.06	30x40	1.96	35x30	1.66			25x55	2.15	30x40	1.94
560					25x55	2.27	30x45	2.17	35x35	1.90					30x45	2.15
680							30x50	2.40	35x40	2.13					30x55	2.51
820								30x55	2.62	35x45	2.36					35x50
1000										35x55	2.77					35x60
1200										35x60	2.97					

Cap. (μ F)	400Vdc					420Vdc				
	ϕ 20	ϕ 22	ϕ 25	ϕ 30	ϕ 35	ϕ 20	ϕ 22	ϕ 25	ϕ 30	ϕ 35
68	20x25	0.69				20x25	0.69			
82	20x25	0.75	22x25	0.78		20x25	0.75	22x25	0.78	
100	20x30	0.87	22x25	0.85		20x30	0.86	22x25	0.85	25x25
120	20x35	0.99	22x30	0.97	25x25	0.96				
150	20x40	1.13	22x35	1.13	25x25	1.04				
180	20x40	1.23	22x35	1.22	25x30	1.20	30x25	1.18		
220	20x50	1.44	22x45	1.44	25x35	1.37	30x25	1.25		
270			22x50	1.62	25x40	1.56	30x30	1.45	35x25	1.34
330			22x55	1.82	25x45	1.76	30x35	1.66	35x30	1.57
390					25x50	1.94	30x40	1.86	35x30	1.60
470					25x55	2.15	30x45	2.07	35x35	1.83
560							30x50	2.28	35x40	2.05
680							30x55	2.50	35x45	2.27
820									35x55	2.65

Cap. (μ F)	450Vdc					500Vdc				
	ϕ 20	ϕ 22	ϕ 25	ϕ 30	ϕ 35	ϕ 20	ϕ 22	ϕ 25	ϕ 30	ϕ 35
39						20x25	0.51			
47						20x30	0.59	22x25	0.58	
56	20x25	0.63				20x35	0.67	22x30	0.66	
68	20x25	0.69	22x25	0.72		20x40	0.76	22x30	0.73	25x25
82	20x30	0.80	22x25	0.78		20x45	0.85	22x35	0.83	25x30
100	20x35	0.91	22x30	0.90	25x25	0.89				30x25
120	20x35	0.99	22x30	0.98	25x25	0.95				
150	20x45	1.18	22x35	1.13	25x30	1.11	30x25	1.10		
180			22x40	1.27	25x35	1.27	30x25	1.16		
220			22x50	1.49	25x40	1.44	30x30	1.35	35x25	1.26
270			22x55	1.68	25x45	1.62	30x35	1.55	35x30	1.48
330					25x50	1.82	30x40	1.75	35x30	1.52
390					25x60	2.07	30x45	1.93	35x35	1.74
470							30x50	2.14	35x40	1.95
560							30x55	2.34	35x45	2.16
680									35x55	2.51
820									35x60	2.71

ケースサイズ Case Size ϕ D x L(mm) \rightarrow
 リプル電流 Ripple Current (A.r.m.s./120Hz, 105°C) \rightarrow

MXH series

105°C 2000~3000 時間
Load Life : 105°C 2000~3000 hours



◆規格表 / SPECIFICATIONS

項目 Item	特性 Characteristics												
カテゴリ温度範囲 Category Temperature Range	-25~+105°C												
定格電圧範囲 Rated Voltage Range	400~600Vdc												
静電容量許容差 Capacitance Tolerance	±20% (20°C, 120Hz)												
漏れ電流 Leakage Current (MAX)	$I=3\sqrt{CV}$ (定格電圧印加5分後) $I=3\sqrt{CV}$ (After 5 minutes application of rated voltage) I=漏れ電流 (μA) C=静電容量 (μF) V=定格電圧 (Vdc) Leakage Current Capacitance Rated Voltage												
損失角の正接 (tan δ) Dissipation Factor (MAX)	<table border="1"> <tr> <td>定格電圧 (Vdc) Rated Voltage</td> <td>400~450</td> <td>475~600</td> <td>(20°C, 120Hz)</td> </tr> <tr> <td>tan δ</td> <td>0.20</td> <td>0.25</td> <td></td> </tr> </table>	定格電圧 (Vdc) Rated Voltage	400~450	475~600	(20°C, 120Hz)	tan δ	0.20	0.25					
定格電圧 (Vdc) Rated Voltage	400~450	475~600	(20°C, 120Hz)										
tan δ	0.20	0.25											
耐久性 Endurance	<p>105°C 中で右表の時間定格電圧 (リップル重畳) 印加後、下記項目を満足すること。 After applying rated voltage with rated ripple current for specified time at 105°C, the capacitors shall meet the following requirements.</p> <table border="1"> <tr> <td>静電容量変化率 Capacitance Change</td> <td>初期値の ±20% 以内 Within ±20% of the initial value.</td> <td>定格電圧 (Vdc) Rated Voltage</td> <td>時間 (hrs) Time (hrs)</td> </tr> <tr> <td>損失角の正接 Dissipation Factor</td> <td>規格値の 200% 以下 Not more than 200% of the specified value.</td> <td>400~500</td> <td>2000</td> </tr> <tr> <td>漏れ電流 Leakage Current</td> <td>規格値以下 Not more than the specified value.</td> <td>550~600</td> <td>3000</td> </tr> </table>	静電容量変化率 Capacitance Change	初期値の ±20% 以内 Within ±20% of the initial value.	定格電圧 (Vdc) Rated Voltage	時間 (hrs) Time (hrs)	損失角の正接 Dissipation Factor	規格値の 200% 以下 Not more than 200% of the specified value.	400~500	2000	漏れ電流 Leakage Current	規格値以下 Not more than the specified value.	550~600	3000
静電容量変化率 Capacitance Change	初期値の ±20% 以内 Within ±20% of the initial value.	定格電圧 (Vdc) Rated Voltage	時間 (hrs) Time (hrs)										
損失角の正接 Dissipation Factor	規格値の 200% 以下 Not more than 200% of the specified value.	400~500	2000										
漏れ電流 Leakage Current	規格値以下 Not more than the specified value.	550~600	3000										
低温特性 Low Temperature Stability (インピーダンス比) Impedance Ratio (MAX)	<table border="1"> <tr> <td>定格電圧 (Vdc) Rated Voltage</td> <td>400~450</td> <td>475, 500</td> <td>550, 600</td> <td>(120Hz)</td> </tr> <tr> <td>Z(-25°C)/Z(+20°C)</td> <td>8</td> <td>10</td> <td>12</td> <td></td> </tr> </table>	定格電圧 (Vdc) Rated Voltage	400~450	475, 500	550, 600	(120Hz)	Z(-25°C)/Z(+20°C)	8	10	12			
定格電圧 (Vdc) Rated Voltage	400~450	475, 500	550, 600	(120Hz)									
Z(-25°C)/Z(+20°C)	8	10	12										

◆呼称方法 / PART NUMBER

MXH M D x L
 Rated Voltage Series Capacitance Capacitance Tolerance Option Terminal Code Case Size

◆リップル電流補正係数 / MULTIPLIER FOR RIPPLE CURRENT

周波数 (Hz) Frequency	60 (50)	120 (100)	300	500	1k	10k ≤
係数 Coefficient	0.80	1.00	1.15	1.20	1.25	1.40

◆副記号 / OPTION

EFC : PET スリーブ、底板なし
PET Sleeve without plate

◆端子記号 / Terminal Code

SN : 標準端子 Standard Terminal

その他の形状は端子形状一覧をご確認ください。
For other type, please refer to the list of terminal type.

◆寸法図/DIMENSIONS

●SN[4(3.5)mm]端子タイプ
SN[4(3.5)mm]terminal type

端子記号 : SN(錫メッキ)
Terminal code : SN(Tin plating)

(mm)

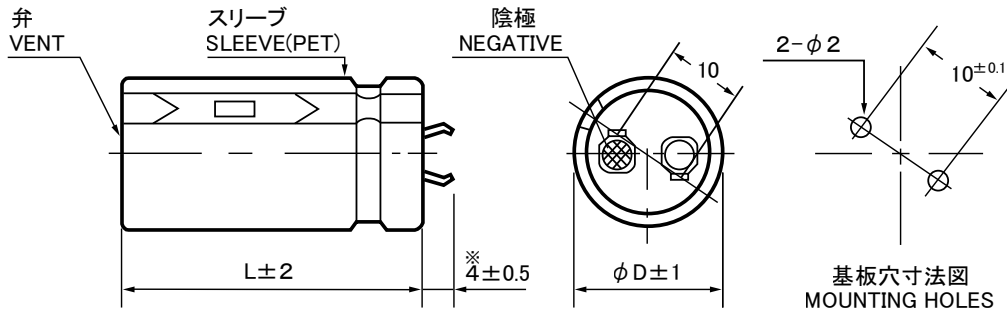

※但しφ35(400~500Vdc)は3.5±0.5
For φ35(400~500Vdc), 3.5±0.5

◆標準品一覧表/STANDARD SIZE

Cap. (μF)	400Vdc							420Vdc								
	φ22	φ25	φ30	φ35	φ35	φ30	φ25	φ22	φ25	φ30	φ35	φ35	φ30	φ25	φ22	
100								22x25	0.85							
120	22x25	0.92						22x30	0.98							
150	22x30	1.08						22x30	1.06	25x25	1.04					
180	22x30	1.15	25x25	1.12				22x35	1.20	25x30	1.20					
220	22x35	1.32	25x30	1.30				22x40	1.37	25x30	1.28	30x25	1.24			
270	22x40	1.50	25x35	1.49	30x25	1.33		22x50	1.62	25x35	1.47	30x30	1.44	35x25	1.32	
330	22x50	1.76	25x40	1.68	30x30	1.55	35x25	1.44	22x60	1.87	25x45	1.75	30x35	1.65	35x30	1.56
390	22x55	1.94	25x45	1.86	30x35	1.75	35x30	1.63			25x50	1.93	30x40	1.84	35x30	1.62
470			25x50	2.07	30x40	1.97	35x30	1.68			25x60	2.21	30x45	2.05	35x35	1.86
560			25x60	2.37	30x45	2.18	35x35	1.92					30x50	2.25	35x40	2.10
680					30x50	2.41	35x40	2.15					30x60	2.59	35x45	2.29
820					30x60	2.76	35x45	2.37							35x50	2.50
1000							35x55	2.78							35x60	2.88
1200							35x60	2.95								

Cap. (μF)	450Vdc							475Vdc								
	φ22	φ25	φ30	φ35	φ35	φ30	φ25	φ22	φ25	φ30	φ35	φ35	φ30	φ25	φ22	
68								22x25	0.67							
82								22x30	0.77							
100	22x25	0.85						22x35	0.88	25x25	0.83					
120	22x30	0.98	25x25	0.96				22x40	0.99	25x30	0.96					
150	22x35	1.13	25x30	1.12				22x45	1.14	25x35	1.10	30x25	1.04			
180	22x40	1.28	25x30	1.20	30x25	1.18		22x50	1.27	25x40	1.24	30x30	1.19	35x25	1.15	
220	22x45	1.44	25x35	1.37	30x30	1.36		22x60	1.47	25x45	1.40	30x35	1.36	35x30	1.33	
270	22x50	1.61	25x40	1.56	30x30	1.44	35x25	1.33			25x55	1.62	30x40	1.54	35x35	1.52
330	22x60	1.86	25x50	1.82	30x35	1.64	35x30	1.54					30x45	1.73	35x40	1.71
390			25x55	2.01	30x40	1.83	35x35	1.76					30x55	1.98	35x40	1.79
470			25x60	2.21	30x45	2.05	35x40	1.97					30x60	2.18	35x50	2.09
560					30x50	2.26	35x45	2.18							35x55	2.29
680					30x60	2.59	35x50	2.38								
820							35x60	2.74								

ケースサイズ Case Size φD×L(mm) ↑
リップル電流 Ripple Current (A.r.m.s./120Hz,105°C) →

◆標準品一覧表 / STANDARD SIZE

Cap. (μ F)	500Vdc								550Vdc							
	ϕ 22		ϕ 25		ϕ 30		ϕ 35		ϕ 22		ϕ 25		ϕ 30		ϕ 35	
47									22x25	0.56						
56	22x25	0.63							22x30	0.64						
68	22x30	0.72							22x30	0.69	25x25	0.69				
82	22x30	0.80	25x25	0.78					22x35	0.80	25x30	0.80				
100	22x35	0.92	25x30	0.90					22x40	0.90	25x35	0.92	30x25	0.80		
120	22x40	1.03	25x35	1.02	30x25	0.97			22x50	1.07	25x40	1.04	30x30	0.93	35x25	0.92
150	22x50	1.20	25x40	1.17	30x30	1.13	35x25	1.09	22x60	1.25	25x45	1.19	30x35	1.07	35x30	1.05
180	22x60	1.37	25x45	1.31	30x35	1.28	35x30	1.26			25x55	1.37	30x40	1.21	35x30	1.14
220			25x50	1.46	30x40	1.45	35x35	1.44			25x60	1.51	30x45	1.36	35x35	1.30
270			25x60	1.70	30x45	1.63	35x35	1.52					30x55	1.57	35x40	1.47
330					30x50	1.81	35x40	1.71							35x50	1.72
390					30x60	2.06	35x50	1.99							35x55	1.88
470							35x55	2.19								

Cap. (μ F)	600Vdc							
	ϕ 22		ϕ 25		ϕ 30		ϕ 35	
39	22x25	0.50						
47	22x30	0.57						
56	22x35	0.65	25x25	0.60				
68	22x35	0.69	25x30	0.71				
82	22x45	0.83	25x35	0.81	30x25	0.77		
100	22x50	0.95	25x40	0.92	30x30	0.90	35x25	0.89
120	22x55	1.03	25x45	1.04	30x35	1.02	35x30	1.02
150			25x55	1.22	30x40	1.17	35x30	1.09
180					30x45	1.31	35x35	1.25
220					30x55	1.53	35x40	1.40
270							35x50	1.67
330							35x55	1.82

ケースサイズ Case Size ϕ D \times L (mm) \uparrow
 リプル電流 Ripple Current (A.r.m.s./120Hz, 105°C) \rightarrow

MXK series

105°C 3000 時間 超小形品
Load Life : 105°C 3000 hours, Ultra Miniaturized



◆規格表 / SPECIFICATIONS

項目 Item	特性 Characteristics																				
カテゴリ温度範囲 Category Temperature Range	-40~+105°C	-25~+105°C																			
定格電圧範囲 Rated Voltage Range	16~250Vdc	400~500Vdc																			
静電容量許容差 Capacitance Tolerance	±20% (20°C, 120Hz)																				
漏れ電流 Leakage Current (MAX)	$I=3\sqrt{CV}$ 又は5mAいずれかの小なる値(定格電圧印加5分後) $I=3\sqrt{CV}$ or 5mA whichever is smaller(After 5 minutes application of rated voltage) I=漏れ電流(μA) C=静電容量(μF) V=定格電圧(Vdc) Leakage Current Capacitance Rated Voltage																				
損失角の正接(tan δ) Dissipation Factor (MAX)	<table border="1"> <tr> <td>定格電圧 (Vdc) Rated Voltage</td> <td>16</td> <td>25</td> <td>35</td> <td>50</td> <td>63</td> <td>80~100</td> <td>160~450</td> <td>475, 500</td> <td rowspan="2">(20°C, 120Hz)</td> </tr> <tr> <td>tan δ</td> <td>0.50</td> <td>0.45</td> <td>0.40</td> <td>0.35</td> <td>0.30</td> <td>0.25</td> <td>0.20</td> <td>0.25</td> </tr> </table>		定格電圧 (Vdc) Rated Voltage	16	25	35	50	63	80~100	160~450	475, 500	(20°C, 120Hz)	tan δ	0.50	0.45	0.40	0.35	0.30	0.25	0.20	0.25
定格電圧 (Vdc) Rated Voltage	16	25	35	50	63	80~100	160~450	475, 500	(20°C, 120Hz)												
tan δ	0.50	0.45	0.40	0.35	0.30	0.25	0.20	0.25													
耐久性 Endurance	105°C 中で3000時間定格電圧(リップル重畳)印加後、下記項目を満足すること。 After applying rated voltage with rated ripple current for 3000 hours at 105°C, the capacitors shall meet the following requirements.																				
	<table border="1"> <tr> <td>静電容量変化率 Capacitance Change</td> <td colspan="2">初期値の ±20% 以内 Within ±20% of the initial value.</td> </tr> <tr> <td>損失角の正接 Dissipation Factor</td> <td colspan="2">規格値の 200% 以下 Not more than 200% of the specified value.</td> </tr> <tr> <td>漏れ電流 Leakage Current</td> <td colspan="2">規格値以下 Not more than the specified value.</td> </tr> </table>		静電容量変化率 Capacitance Change	初期値の ±20% 以内 Within ±20% of the initial value.		損失角の正接 Dissipation Factor	規格値の 200% 以下 Not more than 200% of the specified value.		漏れ電流 Leakage Current	規格値以下 Not more than the specified value.											
静電容量変化率 Capacitance Change	初期値の ±20% 以内 Within ±20% of the initial value.																				
損失角の正接 Dissipation Factor	規格値の 200% 以下 Not more than 200% of the specified value.																				
漏れ電流 Leakage Current	規格値以下 Not more than the specified value.																				
低温特性 Low Temperature Stability (インピーダンス比) Impedance Ratio (MAX)	<table border="1"> <tr> <td>定格電圧 (Vdc) Rated Voltage</td> <td>16~100</td> <td>160~250</td> <td>400~450</td> <td>475, 500</td> <td rowspan="3">(120Hz)</td> </tr> <tr> <td>Z(-25°C)/Z(+20°C)</td> <td>3</td> <td>4</td> <td>8</td> <td>10</td> </tr> <tr> <td>Z(-40°C)/Z(+20°C)</td> <td>12</td> <td>15</td> <td>-</td> <td>-</td> </tr> </table>		定格電圧 (Vdc) Rated Voltage	16~100	160~250	400~450	475, 500	(120Hz)	Z(-25°C)/Z(+20°C)	3	4	8	10	Z(-40°C)/Z(+20°C)	12	15	-	-			
定格電圧 (Vdc) Rated Voltage	16~100	160~250	400~450	475, 500	(120Hz)																
Z(-25°C)/Z(+20°C)	3	4	8	10																	
Z(-40°C)/Z(+20°C)	12	15	-	-																	

◆呼称方法 / PART NUMBER

MXK M D x L
 定格電圧 Rated Voltage シリーズ名 Series 静電容量 Capacitance 静電容量許容差 Capacitance Tolerance 副記号 Option 端子記号 Terminal Code ケースサイズ Case Size

◆リップル電流補正係数 /

MULTIPLIER FOR RIPPLE CURRENT

周波数 (Hz) Frequency	60 (50)	120 (100)	300	500	1k	10k ≤
16~100Vdc	0.90	1.00	1.03	1.05	1.10	1.15
160~250Vdc	0.80	1.00	1.15	1.20	1.30	1.50
400~500Vdc	0.80	1.00	1.15	1.20	1.25	1.40

◆副記号 / OPTION

EFC : PET スリーブ、底板なし
PET Sleeve without plate

◆端子記号 / Terminal Code

SN : 標準端子 Standard Terminal

その他の形状は端子形状一覧をご確認ください。
For other type, please refer to the list of terminal type.

◆標準品一覧表 / STANDARD SIZE

Cap. (μ F)	100Vdc								160Vdc							
	ϕ 22		ϕ 25		ϕ 30		ϕ 35		ϕ 22		ϕ 25		ϕ 30		ϕ 35	
560									22x25	1.60						
680									22x30	1.87	25x25	1.72				
820									22x35	2.14	25x30	1.92				
1000	22x25	2.01							22x40	2.42	25x30	2.07	30x25	1.84		
1200	22x30	2.33							22x45	2.69	25x35	2.36	30x30	2.00		
1500	22x30	2.41	25x25	2.17					22x55	3.17	25x40	2.67	30x30	2.16	35x25	1.77
1800	22x35	2.74	25x30	2.54					22x60	3.46	25x50	3.18	30x35	2.46	35x30	2.13
2200	22x40	3.05	25x35	2.89	30x25	3.15					25x55	3.48	30x40	2.77	35x35	2.45
2700	22x50	3.59	25x40	3.21	30x30	3.67	35x25	3.31					30x50	3.32	35x40	2.73
3300	22x55	3.89	25x45	3.51	30x35	4.15	35x30	3.88					30x55	3.59	35x45	2.96
3900			25x50	3.79	30x40	4.60	35x30	3.89							35x50	3.23
4700			25x60	4.31	30x45	5.04	35x35	4.40							35x60	3.72
5600					30x50	5.46	35x40	4.87								
6800					30x60	6.16	35x45	5.32								
8200							35x55	6.10								

Cap. (μ F)	180Vdc								200Vdc							
	ϕ 22		ϕ 25		ϕ 30		ϕ 35		ϕ 22		ϕ 25		ϕ 30		ϕ 35	
470	22x25	1.53							22x25	1.53						
560	22x30	1.75							22x30	1.78	25x25	1.65				
680	22x30	1.87	25x25	1.70					22x35	2.04	25x30	1.85				
820	22x35	2.13	25x30	2.00					22x40	2.30	25x30	1.99	30x25	1.79		
1000	22x40	2.41	25x35	2.29	30x25	1.79			22x45	2.58	25x35	2.28	30x30	1.94		
1200	22x50	2.85	25x40	2.58	30x30	2.13	35x25	1.79	22x50	2.85	25x40	2.56	30x30	2.10	35x25	1.75
1500	22x60	3.32	25x45	2.87	30x35	2.44	35x30	1.91			25x50	3.06	30x35	2.41	35x30	2.09
1800			25x55	3.36	30x40	2.73	35x30	2.09			25x60	3.52	30x45	2.99	35x35	2.41
2200					30x45	3.00	35x35	2.38					30x50	3.22	35x40	2.66
2700						30x55	3.53	35x45	2.99				30x60	3.72	35x45	2.91
3300								35x50	3.21						35x55	3.43
3900								35x55	3.45						35x60	3.66

Cap. (μ F)	220Vdc								250Vdc							
	ϕ 22		ϕ 25		ϕ 30		ϕ 35		ϕ 22		ϕ 25		ϕ 30		ϕ 35	
330									22x25	1.38						
390	22x25	1.46							22x30	1.58						
470	22x30	1.70							22x30	1.68	25x25	1.55				
560	22x35	1.93	25x25	1.64					22x35	1.91	25x30	1.81				
680	22x40	2.19	25x30	1.91					22x40	2.16	25x35	2.07	30x25	1.66		
820	22x45	2.44	25x35	2.19	30x25	1.74			22x50	2.55	25x40	2.33	30x30	1.97	35x25	1.68
1000	22x50	2.72	25x40	2.47	30x30	2.06	35x25	1.74	22x55	2.82	25x45	2.59	30x35	2.26	35x30	1.89
1200	22x60	3.13	25x45	2.74	30x35	2.36	35x30	2.09			25x50	2.86	30x40	2.51	35x30	1.94
1500			25x55	3.22	30x40	2.64	35x35	2.22					30x45	2.76	35x35	2.22
1800					30x45	2.91	35x35	2.34					30x50	3.03	35x40	2.49
2200						30x55	3.42	35x45	2.92				30x60	3.49	35x50	3.00
2700								35x50	3.13						35x55	3.23
3300								35x60	3.62							

Cap. (μ F)	400Vdc								420Vdc								
	ϕ 22		ϕ 25		ϕ 30		ϕ 35		ϕ 22		ϕ 25		ϕ 30		ϕ 35		
120									22x25	0.95							
150	22x25	1.03							22x25	1.02							
180	22x30	1.19	25x25	1.15					22x30	1.20	25x25	1.16					
220	22x30	1.26	25x25	1.20					22x35	1.38	25x30	1.35					
270	22x35	1.37	25x30	1.32					22x40	1.57	25x35	1.55	30x25	1.36			
330	22x45	1.77	25x35	1.65	30x25	1.39			22x45	1.72	25x35	1.61	30x30	1.59	35x25	1.45	
390	22x50	1.97	25x40	1.85	30x30	1.65	35x25	1.48	22x50	1.85	25x40	1.76	30x30	1.61	35x25	1.45	
470	22x55	2.11	25x45	2.07	30x35	1.89	35x30	1.69	22x60	2.19	25x50	2.18	30x35	1.85	35x30	1.72	
560	22x60	2.20									25x55	2.32	30x40	2.04			
680			25x55	2.32	30x40	2.12	35x30	1.75			25x60	2.43	30x40	2.07	35x35	1.97	
820					30x45	2.35	35x35	2.00					30x45	2.27	35x40	2.22	
1000						30x50	2.53	35x40	2.21				30x50	2.29			
1200						30x55	2.66	35x45	2.48				30x55	2.50			
						30x60	2.91	35x50	2.70				30x60	2.68	35x45	2.45	
								35x55	2.85					30x60	2.79	35x50	2.64
								35x60	2.99						35x55	2.76	
															35x60	3.03	

◆標準品一覧表 / STANDARD SIZE

Cap. (μ F)	450Vdc								475Vdc							
	ϕ 22		ϕ 25		ϕ 30		ϕ 35		ϕ 22		ϕ 25		ϕ 30		ϕ 35	
82									22x25	0.79						
100									22x30	0.90	25x25	0.90				
120	22x25	0.95							22x25	0.84	25x30	1.02				
								22x30	0.97							
150	22x30	1.12	25x25	1.08					22x30	1.00	25x25	0.98	30x25	1.11		
									22x35	1.13	25x30	1.12				
180	22x30	1.17	25x25	1.14					22x35	1.14	25x30	1.13	30x30	1.27		
	22x35	1.27	25x30	1.24					22x40	1.27	25x35	1.27				
220	22x35	1.34	25x30	1.34	30x25	1.29			22x40	1.30	25x35	1.29	30x25	1.18	35x25	1.27
	22x40	1.45							22x45	1.44	25x40	1.44	30x30	1.37		
270	22x40	1.53	25x35	1.54	30x25	1.34			22x45	1.45	25x40	1.47	30x30	1.38	35x25	1.30
	22x45	1.65			30x30	1.49			22x55	1.68	25x45	1.63	30x35	1.56	35x30	1.51
330	22x50	1.81	25x40	1.72	30x30	1.58	35x25	1.42	22x55	1.72	25x45	1.67	30x35	1.59	35x30	1.57
	22x55	1.88	25x45	1.85							25x50	1.83	30x40	1.77		
390	22x55	1.98	25x45	1.91	30x35	1.80	35x30	1.68			25x50	1.84	30x40	1.85	35x30	1.57
	22x60	2.07	25x50	2.04							25x60	2.08			35x35	1.79
470			25x55	2.21	30x40	2.02	35x30	1.69			25x60	2.13	30x45	1.99	35x35	1.79
							35x35	1.92					30x50	2.17	35x40	2.00
560			25x60	2.41	30x45	2.24	35x35	1.92					30x50	2.18	35x40	2.00
							35x40	2.15			30x55	2.38	35x45	2.22		
680					30x50	2.41	35x40	2.16					30x60	2.52	35x45	2.20
					30x55	2.54	35x45	2.38							35x50	2.45
820					30x60	2.77	35x45	2.36							35x55	2.59
							35x50	2.59							35x60	2.80
1000							35x55	2.78								
							35x60	2.90								

Cap. (μ F)	500Vdc							
	ϕ 22		ϕ 25		ϕ 30		ϕ 35	
68	22x25	0.73						
82	22x30	0.83						
100	22x25	0.80						
	22x30	0.91						
120	22x30	0.92	25x30	1.03				
	22x35	1.03						
150	22x40	1.18	25x25	0.96				
			25x30	1.12				
180	22x35	1.13	25x30	1.13	30x30	1.28	35x25	1.20
	22x45	1.33	25x35	1.28				
220	22x45	1.37	25x35	1.30	30x25	1.18	35x30	1.42
	22x50	1.50	25x40	1.45	30x30	1.36		
270	22x50	1.55	25x40	1.49	30x30	1.38	35x25	1.29
	22x60	1.73	25x50	1.70	30x35	1.56	35x30	1.50
330	22x60	1.78	25x50	1.76	30x35	1.57	35x30	1.51
			25x55	1.90	30x40	1.76	35x35	1.71
390			25x55	1.91	30x45	1.95	35x35	1.72
							35x40	1.91
470					30x50	2.09	35x40	1.93
					30x55	2.26	35x45	2.13
560					30x55	2.28	35x45	2.13
					30x60	2.47	35x50	2.33
680							35x50	2.34
							35x55	2.56
820							35x60	2.68

ケースサイズ Case Size ϕ D×L(mm)

リップル電流 Ripple Current (A.r.m.s./120Hz,105°C)

MXT series

105°C 3000 時間 超小形化品
Load Life : 105°C 3000 hours, Ultra Miniaturized



◆規格表 / SPECIFICATIONS

項目 Item	特性 Characteristics						
カテゴリ温度範囲 Category Temperature Range	-25~+105°C						
定格電圧範囲 Rated Voltage Range	400~475Vdc						
静電容量許容差 Capacitance Tolerance	±20% (20°C, 120Hz)						
漏れ電流 Leakage Current (MAX)	$I=3\sqrt{CV}$ (定格電圧印加5分後) $I=3\sqrt{CV}$ (After 5 minutes application of rated voltage) I=漏れ電流 (μA) C=静電容量 (μF) V=定格電圧 (Vdc) Leakage Current Capacitance Rated Voltage						
損失角の正接 (tan δ) Dissipation Factor (MAX)	<table border="1"> <tr> <td>定格電圧 (Vdc) Rated Voltage</td> <td>400~475</td> <td rowspan="2">(20°C, 120Hz)</td> </tr> <tr> <td>tan δ</td> <td>0.25</td> </tr> </table>	定格電圧 (Vdc) Rated Voltage	400~475	(20°C, 120Hz)	tan δ	0.25	
定格電圧 (Vdc) Rated Voltage	400~475	(20°C, 120Hz)					
tan δ	0.25						
耐久性 Endurance	105°Cで3000時間定格電圧(リップル重畳)印加後、下記項目を満足すること。 After applying rated voltage with rated ripple current for 3000 hours at 105°C, the capacitors shall meet the following requirements. <table border="1"> <tr> <td>静電容量変化率 Capacitance Change</td> <td>初期値の ±20% 以内 Within ±20% of the initial value.</td> </tr> <tr> <td>損失角の正接 Dissipation Factor</td> <td>規格値の 200% 以下 Not more than 200% of the specified value.</td> </tr> <tr> <td>漏れ電流 Leakage Current</td> <td>規格値以下 Not more than the specified value.</td> </tr> </table>	静電容量変化率 Capacitance Change	初期値の ±20% 以内 Within ±20% of the initial value.	損失角の正接 Dissipation Factor	規格値の 200% 以下 Not more than 200% of the specified value.	漏れ電流 Leakage Current	規格値以下 Not more than the specified value.
静電容量変化率 Capacitance Change	初期値の ±20% 以内 Within ±20% of the initial value.						
損失角の正接 Dissipation Factor	規格値の 200% 以下 Not more than 200% of the specified value.						
漏れ電流 Leakage Current	規格値以下 Not more than the specified value.						
低温特性 Low Temperature Stability (インピーダンス比) Impedance Ratio (MAX)	<table border="1"> <tr> <td>定格電圧 (Vdc) Rated Voltage</td> <td>400~475</td> <td rowspan="2">(120Hz)</td> </tr> <tr> <td>Z(-25°C)/Z(+20°C)</td> <td>12</td> </tr> </table>	定格電圧 (Vdc) Rated Voltage	400~475	(120Hz)	Z(-25°C)/Z(+20°C)	12	
定格電圧 (Vdc) Rated Voltage	400~475	(120Hz)					
Z(-25°C)/Z(+20°C)	12						

◆呼称方法 / PART NUMBER

□□□
MXT
□□□□□
M
□□□
□□
D x L
 Rated Voltage Series Capacitance Capacitance Tolerance Option Terminal Code Case Size

◆リップル電流補正係数 /

MULTIPLIER FOR RIPPLE CURRENT

周波数 (Hz) Frequency	60 (50)	120 (100)	300	500	1k	10k ≤
係数 Coefficient	0.80	1.00	1.15	1.20	1.25	1.40

◆副記号 / OPTION

EFC : PET スリーブ、底板なし
PET Sleeve without plate

◆端子記号 / Terminal Code

SN : 標準端子 Standard Terminal

その他の形状は端子形状一覧をご確認ください。
For other type, please refer to the list of terminal type.

◆寸法図／DIMENSIONS

●SN[4mm]端子タイプ
SN[4mm]terminal type

端子記号 : SN(錫メッキ)
Terminal code : SN(Tin plating)

(mm)

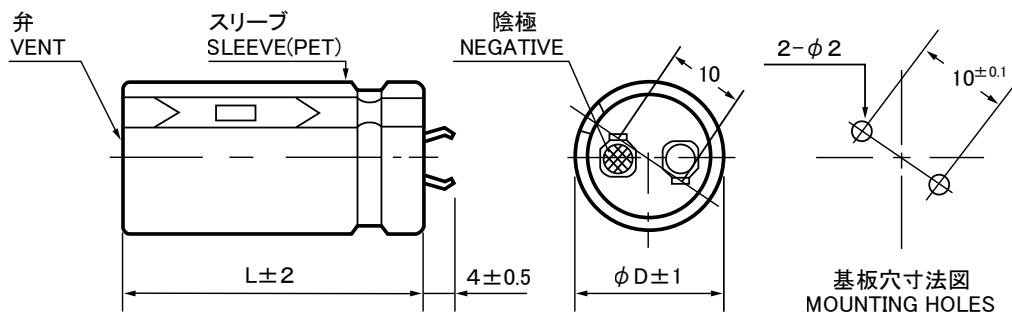

◆標準品一覧表／STANDARD SIZE

Cap. (μ F)	400Vdc							420Vdc								
	ϕ 22		ϕ 25		ϕ 30		ϕ 35	ϕ 22		ϕ 25		ϕ 30		ϕ 35		
150								22x25	0.92							
180	22x25	0.98						22x30	1.06							
220	22x30	1.14	25x25	1.10				22x30	1.15	25x25	1.11					
270	22x35	1.32	25x30	1.29				22x35	1.33	25x30	1.29					
330	22x40	1.48	25x30	1.36	30x25	1.31		22x40	1.50	25x35	1.49	30x25	1.30			
390	22x45	1.66	25x35	1.56	30x30	1.52		22x45	1.67	25x40	1.67	30x30	1.52			
470	22x50	1.85	25x40	1.75	30x30	1.57	35x25	1.40	22x55	1.95	25x40	1.73	30x35	1.74	35x25	1.39
560	22x60	2.14	25x45	1.94	30x35	1.80	35x30	1.67	22x60	2.11	25x50	2.07	30x35	1.78	35x30	1.65
680			25x55	2.29	30x40	2.04	35x35	1.91			25x60	2.39	30x40	2.02	35x35	1.89
820					30x45	2.26	35x40	2.17					30x50	2.42	35x40	2.16
1000					30x55	2.65	35x45	2.41					30x60	2.79	35x45	2.39
1200							35x50	2.62							35x55	2.79
1500							35x60	3.03								

Cap. (μ F)	450Vdc							475Vdc								
	ϕ 22		ϕ 25		ϕ 30		ϕ 35	ϕ 22		ϕ 25		ϕ 30		ϕ 35		
150	22x25	0.93														
180	22x30	1.08	25x25	1.04				22x30	1.06							
220	22x35	1.24	25x30	1.21				22x35	1.22	25x30	1.22					
270	22x40	1.40	25x30	1.29	30x25	1.25		22x45	1.48	25x35	1.40					
330	22x45	1.59	25x35	1.49	30x30	1.41		22x50	1.67	25x40	1.60	30x30	1.48			
390	22x50	1.76	25x40	1.67	30x30	1.45	35x25	1.28	22x55	1.82	25x45	1.78	30x35	1.68		
470	22x60	2.04	25x45	1.86	30x35	1.66	35x30	1.52			25x55	2.07	30x40	1.89	35x30	1.63
560			25x55	2.18	30x40	1.96	35x35	1.74			25x60	2.24	30x45	2.10	35x35	1.86
680					30x45	2.17	35x40	2.10					30x55	2.45	35x45	2.26
820					30x55	2.55	35x45	2.33							35x50	2.49
1000							35x50	2.55							35x60	2.87
1200							35x60	2.94								

ケースサイズ Case Size $\phi D \times L$ (mm) \uparrow
リップル電流 Ripple Current (A.r.m.s./120Hz, 105°C) \rightarrow

NXH series

105°C 10000 時間
Load Life : 105°C 10000 hours



◆規格表 / SPECIFICATIONS

項目 Item	特性 Characteristics							
カテゴリ温度範囲 Category Temperature Range	-25~+105°C							
定格電圧範囲 Rated Voltage Range	400~500Vdc							
静電容量許容差 Capacitance Tolerance	±20% (20°C, 120Hz)							
漏れ電流 Leakage Current (MAX)	$I=3\sqrt{CV}$ (定格電圧印加5分後) $I=3\sqrt{CV}$ (After 5 minutes application of rated voltage) I=漏れ電流(μA) C=静電容量(μF) V=定格電圧(Vdc) Leakage Current Capacitance Rated Voltage							
損失角の正接 (tan δ) Dissipation Factor (MAX)	<table border="1"> <tr> <td>定格電圧 (Vdc) Rated Voltage</td> <td>400~450</td> <td>475, 500</td> <td rowspan="2">(20°C, 120Hz)</td> </tr> <tr> <td>tan δ</td> <td>0.20</td> <td>0.25</td> </tr> </table>	定格電圧 (Vdc) Rated Voltage	400~450	475, 500	(20°C, 120Hz)	tan δ	0.20	0.25
定格電圧 (Vdc) Rated Voltage	400~450	475, 500	(20°C, 120Hz)					
tan δ	0.20	0.25						
耐久性 Endurance	105°C中で10000時間定格電圧(リップル重畳)印加後、下記項目を満足すること。 After applying rated voltage with rated ripple current for 10000 hours at 105°C, the capacitors shall meet the following requirements. <table border="1"> <tr> <td>静電容量変化率 Capacitance Change</td> <td>初期値の ±20% 以内 Within ±20% of the initial value.</td> </tr> <tr> <td>損失角の正接 Dissipation Factor</td> <td>規格値の 200% 以下 Not more than 200% of the specified value.</td> </tr> <tr> <td>漏れ電流 Leakage Current</td> <td>規格値以下 Not more than the specified value.</td> </tr> </table>	静電容量変化率 Capacitance Change	初期値の ±20% 以内 Within ±20% of the initial value.	損失角の正接 Dissipation Factor	規格値の 200% 以下 Not more than 200% of the specified value.	漏れ電流 Leakage Current	規格値以下 Not more than the specified value.	
静電容量変化率 Capacitance Change	初期値の ±20% 以内 Within ±20% of the initial value.							
損失角の正接 Dissipation Factor	規格値の 200% 以下 Not more than 200% of the specified value.							
漏れ電流 Leakage Current	規格値以下 Not more than the specified value.							
低温特性 Low Temperature Stability (インピーダンス比) Impedance Ratio (MAX)	<table border="1"> <tr> <td>定格電圧 (Vdc) Rated Voltage</td> <td>400~450</td> <td>475, 500</td> <td rowspan="2">(120Hz)</td> </tr> <tr> <td>Z(-25°C)/Z(+20°C)</td> <td>8</td> <td>10</td> </tr> </table>	定格電圧 (Vdc) Rated Voltage	400~450	475, 500	(120Hz)	Z(-25°C)/Z(+20°C)	8	10
定格電圧 (Vdc) Rated Voltage	400~450	475, 500	(120Hz)					
Z(-25°C)/Z(+20°C)	8	10						

◆呼称方法 / PART NUMBER

NXH M D x L
 定格電圧 シリーズ名 静電容量 静電容量許容差 副記号 端子記号 ケースサイズ
 Rated Voltage Series Capacitance Capacitance Tolerance Option Terminal Code Case Size

◆リップル電流補正係数 /

MULTIPLIER FOR RIPPLE CURRENT

周波数 (Hz) Frequency	60 (50)	120 (100)	300	500	1k	10k ≤
係数 Coefficient	0.80	1.00	1.15	1.20	1.25	1.40

◆副記号 / OPTION

EFC : PET スリーブ、底板なし
PET Sleeve without plate

◆端子記号 / Terminal Code

SN : 標準端子 Standard Terminal

その他の形状は端子形状一覧をご確認ください。
For other type, please refer to the list of terminal type.

◆寸法図／DIMENSIONS

●SN[4mm]端子タイプ
SN[4mm]terminal type

端子記号 : SN(錫メッキ)
Terminal code : SN(Tin plating)

(mm)

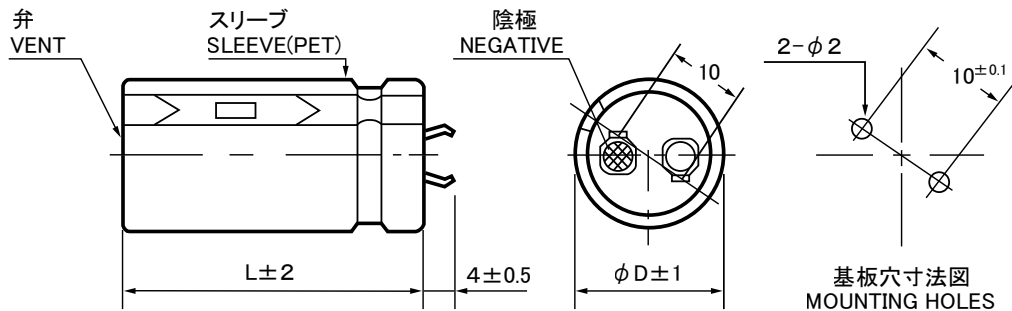

◆標準品一覧表／STANDARD SIZE

Cap. (μ F)	400Vdc								420Vdc							
	ϕ 22		ϕ 25		ϕ 30		ϕ 35		ϕ 22		ϕ 25		ϕ 30		ϕ 35	
150	22x35	1.06							22x35	1.10						
180	22x40	1.21	25x30	1.13					22x40	1.24	25x35	1.23	30x25	1.14		
220	22x45	1.37	25x35	1.30					22x50	1.46	25x40	1.41	30x30	1.33	35x25	1.26
270	22x50	1.52	25x40	1.47	30x30	1.39	35x25	1.30	22x55	1.62	25x45	1.59	30x35	1.53	35x30	1.48
330	22x60	1.77	25x50	1.75	30x35	1.59	35x30	1.53			25x50	1.76	30x40	1.73	35x30	1.54
390			25x55	1.93	30x40	1.79	35x35	1.74			25x60	2.04	30x45	1.92	35x35	1.76
470					30x45	1.98	35x35	1.78					30x50	2.12	35x40	1.97
560					30x55	2.31	35x45	2.17					30x60	2.45	35x45	2.17
680							35x50	2.38							35x55	2.54
820							35x60	2.75								

Cap. (μ F)	450Vdc								475Vdc							
	ϕ 22		ϕ 25		ϕ 30		ϕ 35		ϕ 22		ϕ 25		ϕ 30		ϕ 35	
120	22x35	1.00							22x40	1.00	25x30	0.96				
150	22x40	1.16	25x30	1.08	30x25	1.08			22x45	1.15	25x35	1.11				
180	22x45	1.30	25x35	1.24	30x30	1.25			22x50	1.28	25x40	1.25	30x30	1.19	35x25	1.15
220	22x50	1.44	25x40	1.40	30x30	1.33	35x25	1.26	22x60	1.49	25x50	1.47	30x35	1.37	35x30	1.34
270	22x60	1.68	25x50	1.67	30x35	1.53	35x30	1.47			25x55	1.64	30x40	1.55	35x35	1.53
330			25x55	1.83	30x40	1.72	35x35	1.69					30x50	1.83	35x40	1.74
390					30x45	1.90	35x40	1.89					30x55	2.01	35x45	1.93
470					30x55	2.23	35x45	2.10							35x50	2.13
560							35x50	2.30							35x60	2.44
680							35x60	2.65								

Cap. (μ F)	500Vdc							
	ϕ 22		ϕ 25		ϕ 30		ϕ 35	
100	22x40	0.94	25x30	0.90				
120	22x45	1.06	25x35	1.02	30x25	0.95		
150	22x50	1.20	25x40	1.18	30x30	1.13	35x25	1.09
180	22x60	1.40	25x45	1.30	30x35	1.28	35x30	1.26
220			25x55	1.54	30x40	1.46	35x35	1.45
270					30x45	1.62	35x40	1.64
330					30x55	1.91	35x45	1.84
390							35x50	2.03
470							35x55	2.20

ケースサイズ Case Size ϕ D × L(mm) \uparrow
リップル電流 Ripple Current (A.r.m.s./120Hz,105°C) \uparrow

NXK series

105°C 10000 時間
Load Life : 105°C 10000 hours



◆規格表 / SPECIFICATIONS

項目 Item	特性 Characteristics								
カテゴリ温度範囲 Category Temperature Range	-25~+105°C								
定格電圧範囲 Rated Voltage Range	400~500Vdc								
静電容量許容差 Capacitance Tolerance	±20% (20°C, 120Hz)								
漏れ電流 Leakage Current (MAX)	$I=3\sqrt{CV}$ (定格電圧印加5分後) $I=3\sqrt{CV}$ (After 5 minutes application of rated voltage) I=漏れ電流(μA) C=静電容量(μF) V=定格電圧(Vdc) Leakage Current Capacitance Rated Voltage								
損失角の正接 (tan δ) Dissipation Factor (MAX)	<table border="1"> <tr> <td>定格電圧 (Vdc) Rated Voltage</td> <td>400~450</td> <td>475, 500</td> <td>(20°C, 120Hz)</td> </tr> <tr> <td>tan δ</td> <td>0.20</td> <td>0.25</td> <td></td> </tr> </table>	定格電圧 (Vdc) Rated Voltage	400~450	475, 500	(20°C, 120Hz)	tan δ	0.20	0.25	
定格電圧 (Vdc) Rated Voltage	400~450	475, 500	(20°C, 120Hz)						
tan δ	0.20	0.25							
耐久性 Endurance	105°C中で10000時間定格電圧(リップル重畳)印加後、下記項目を満足すること。 After applying rated voltage with rated ripple current for 10000 hours at 105°C, the capacitors shall meet the following requirements.								
	<table border="1"> <tr> <td>静電容量変化率 Capacitance Change</td> <td>初期値の ±20% 以内 Within ±20% of the initial value.</td> </tr> <tr> <td>損失角の正接 Dissipation Factor</td> <td>規格値の 200% 以下 Not more than 200% of the specified value.</td> </tr> <tr> <td>漏れ電流 Leakage Current</td> <td>規格値以下 Not more than the specified value.</td> </tr> </table>	静電容量変化率 Capacitance Change	初期値の ±20% 以内 Within ±20% of the initial value.	損失角の正接 Dissipation Factor	規格値の 200% 以下 Not more than 200% of the specified value.	漏れ電流 Leakage Current	規格値以下 Not more than the specified value.		
静電容量変化率 Capacitance Change	初期値の ±20% 以内 Within ±20% of the initial value.								
損失角の正接 Dissipation Factor	規格値の 200% 以下 Not more than 200% of the specified value.								
漏れ電流 Leakage Current	規格値以下 Not more than the specified value.								
低温特性 Low Temperature Stability (インピーダンス比) Impedance Ratio (MAX)	<table border="1"> <tr> <td>定格電圧 (Vdc) Rated Voltage</td> <td>400~450</td> <td>475, 500</td> <td>(120Hz)</td> </tr> <tr> <td>Z(-25°C)/Z(+20°C)</td> <td>8</td> <td>10</td> <td></td> </tr> </table>	定格電圧 (Vdc) Rated Voltage	400~450	475, 500	(120Hz)	Z(-25°C)/Z(+20°C)	8	10	
定格電圧 (Vdc) Rated Voltage	400~450	475, 500	(120Hz)						
Z(-25°C)/Z(+20°C)	8	10							

◆呼称方法 / PART NUMBER

NXK M D x L
 定格電圧 Rated Voltage シリーズ名 Series 静電容量 Capacitance 静電容量許容差 Capacitance Tolerance 副記号 Option 端子記号 Terminal Code ケースサイズ Case Size

◆リップル電流補正係数 /

MULTIPLIER FOR RIPPLE CURRENT

周波数 (Hz) Frequency	60 (50)	120 (100)	300	500	1k	10k ≤
係数 Coefficient	0.80	1.00	1.15	1.20	1.25	1.40

◆副記号 / OPTION

EFC : PET スリーブ、底板なし
PET Sleeve without plate

◆端子記号 / Terminal Code

SN : 標準端子 Standard Terminal

その他の形状は端子形状一覧をご確認ください。
For other type, please refer to the list of terminal type.

◆寸法図／DIMENSIONS

●SN[4mm]端子タイプ
SN[4mm]terminal type

端子記号 : SN(錫メッキ)
Terminal code : SN(Tin plating)

(mm)

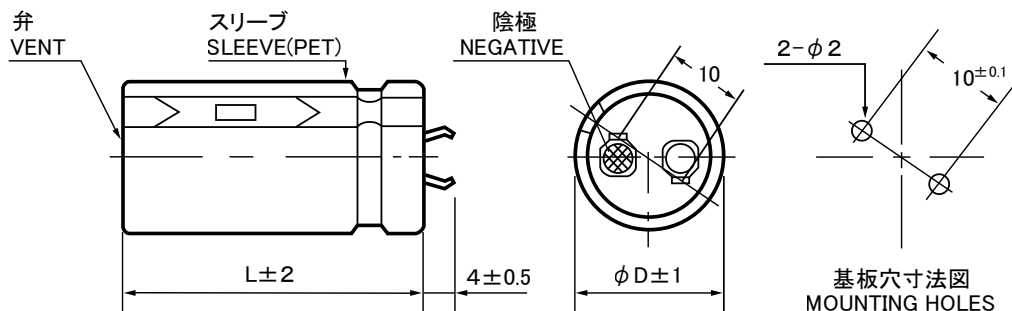

◆標準品一覧表／STANDARD SIZE

Cap. (μF)	400Vdc								420Vdc							
	$\phi 22$		$\phi 25$		$\phi 30$		$\phi 35$		$\phi 22$		$\phi 25$		$\phi 30$		$\phi 35$	
180	22x35	1.13							22x35	1.15						
220	22x40	1.29	25x35	1.29	30x25	1.19			22x45	1.39	25x35	1.32	30x25	1.20		
270	22x45	1.44	25x40	1.47	30x30	1.38	35x25	1.31	22x50	1.57	25x40	1.51	30x30	1.41	35x25	1.33
330	22x55	1.71	25x45	1.66	30x35	1.59	35x30	1.53	22x60	1.82	25x45	1.68	30x35	1.62	35x30	1.56
390			25x50	1.84	30x35	1.65	35x30	1.59			25x55	1.96	30x40	1.82	35x30	1.59
470			25x60	2.11	30x40	1.85	35x35	1.81			25x60	2.14	30x45	2.03	35x35	1.83
560					30x50	2.20	35x40	2.03					30x50	2.21	35x40	2.04
680					30x55	2.40	35x45	2.26					30x60	2.57	35x50	2.44
820							35x55	2.63							35x55	2.64

Cap. (μF)	450Vdc								475Vdc							
	$\phi 22$		$\phi 25$		$\phi 30$		$\phi 35$		$\phi 22$		$\phi 25$		$\phi 30$		$\phi 35$	
150									22x40	1.09						
180	22x40	1.24							22x45	1.22	25x35	1.16				
220	22x45	1.39	25x35	1.30					22x55	1.43	25x40	1.31	30x30	1.24	35x25	1.21
270	22x55	1.63	25x45	1.59	30x30	1.39	35x25	1.31			25x50	1.58	30x35	1.43	35x30	1.42
330			25x50	1.78	30x35	1.60	35x30	1.55			25x60	1.82	30x45	1.73	35x35	1.62
390			25x60	2.04	30x40	1.80	35x35	1.76					30x50	1.92	35x40	1.81
470					30x50	2.14	35x40	1.98					30x55	2.10	35x45	2.02
560					30x55	2.33	35x45	2.20							35x50	2.23
680							35x55	2.56							35x60	2.56
820							35x60	2.76								

Cap. (μF)	500Vdc							
	$\phi 22$		$\phi 25$		$\phi 30$		$\phi 35$	
120	22x35	0.94						
150	22x45	1.15	25x35	1.10	30x25	1.01		
180	22x50	1.29	25x40	1.25	30x30	1.19	35x25	1.15
220	22x60	1.49	25x45	1.40	30x35	1.36	35x30	1.34
270			25x55	1.65	30x40	1.55	35x30	1.39
330					30x45	1.73	35x35	1.60
390					30x55	2.01	35x40	1.80
470					30x60	2.19	35x50	2.13
560							35x55	2.34

ケースサイズ Case Size $\phi D \times L$ (mm) \uparrow
リップル電流 Ripple Current (A.r.m.s./120Hz,105°C) \uparrow

THH series

125°C 2000 時間品
Load Life : 125°C 2000 hours



◆規格表 / SPECIFICATIONS

項目 Item	特性 Characteristics						
カテゴリ温度範囲 Category Temperature Range	-25~+125°C						
定格電圧範囲 Rated Voltage Range	400~450Vdc						
静電容量許容差 Capacitance Tolerance	±20% (20°C, 120Hz)						
漏れ電流 Leakage Current (MAX)	$I=5\sqrt{CV}$ (定格電圧印加5分後) $I=5\sqrt{CV}$ (After 5 minutes application of rated voltage) I=漏れ電流(μA) C=静電容量(μF) V=定格電圧(Vdc) Leakage Current Capacitance Rated Voltage						
損失角の正接 (tan δ) Dissipation Factor (MAX)	<table border="1"> <tr> <td>定格電圧 (Vdc) Rated Voltage</td> <td>400~450</td> <td rowspan="2">(20°C, 120Hz)</td> </tr> <tr> <td>tan δ</td> <td>0.25</td> </tr> </table>	定格電圧 (Vdc) Rated Voltage	400~450	(20°C, 120Hz)	tan δ	0.25	
定格電圧 (Vdc) Rated Voltage	400~450	(20°C, 120Hz)					
tan δ	0.25						
耐久性 Endurance	125°C中で2000時間定格電圧(リップル重畳)印加後、下記項目を満足すること。 After applying rated voltage with rated ripple current for 2000 hours at 125°C, the capacitors shall meet the following requirements.						
	<table border="1"> <tr> <td>静電容量変化率 Capacitance Change</td> <td>初期値の ±20% 以内 Within ±20% of the initial value.</td> </tr> <tr> <td>損失角の正接 Dissipation Factor</td> <td>規格値の 200% 以下 Not more than 200% of the specified value.</td> </tr> <tr> <td>漏れ電流 Leakage Current</td> <td>規格値以下 Not more than the specified value.</td> </tr> </table>	静電容量変化率 Capacitance Change	初期値の ±20% 以内 Within ±20% of the initial value.	損失角の正接 Dissipation Factor	規格値の 200% 以下 Not more than 200% of the specified value.	漏れ電流 Leakage Current	規格値以下 Not more than the specified value.
静電容量変化率 Capacitance Change	初期値の ±20% 以内 Within ±20% of the initial value.						
損失角の正接 Dissipation Factor	規格値の 200% 以下 Not more than 200% of the specified value.						
漏れ電流 Leakage Current	規格値以下 Not more than the specified value.						
低温特性 Low Temperature Stability (インピーダンス比) Impedance Ratio (MAX)	<table border="1"> <tr> <td>定格電圧 (Vdc) Rated Voltage</td> <td>400~450</td> <td rowspan="2">(120Hz)</td> </tr> <tr> <td>Z(-25°C)/Z(+20°C)</td> <td>10</td> </tr> </table>	定格電圧 (Vdc) Rated Voltage	400~450	(120Hz)	Z(-25°C)/Z(+20°C)	10	
定格電圧 (Vdc) Rated Voltage	400~450	(120Hz)					
Z(-25°C)/Z(+20°C)	10						

◆呼称方法 / PART NUMBER

□□□ THH □□□□□ M □□□ □□ D x L
 Rated Voltage Series Capacitance Capacitance Tolerance Option Terminal Code Case Size

◆リップル電流補正係数 /
MULTIPLIER FOR RIPPLE CURRENT

周波数 (Hz) Frequency	60 (50)	120 (100)	300	500	1k	10k ≤
係数 Coefficient	0.80	1.00	1.15	1.20	1.25	1.40

◆副記号 / OPTION

EFC : PET スリーブ、底板なし
PET Sleeve without plate

◆端子記号 / Terminal Code

SN : 標準端子 Standard Terminal

その他の形状は端子形状一覧をご確認ください。
For other type, please refer to the list of terminal type.

◆寸法図/DIMENSIONS

●SN[4mm]端子タイプ
SN[4mm]terminal type

端子記号 : SN(錫メッキ)
Terminal code : SN(Tin plating)

(mm)

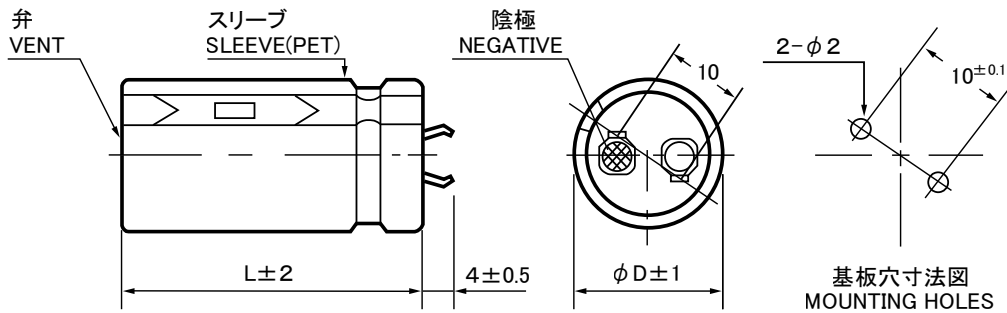

◆標準品一覧表/STANDARD SIZE

Cap.(μF)	400Vdc							
	φ22		φ25		φ30		φ35	
82	22x25	0.79						
100	22x30	0.91						
120	22x30	0.98	25x25	0.96				
150	22x35	1.14	25x30	1.12				
180	22x40	1.28	25x35	1.28				
220	22x50	1.50	25x40	1.45	30x30	1.35		
270	22x55	1.69	25x45	1.64	30x35	1.55		
330			25x55	1.90	30x40	1.75		
390			25x60	2.09	30x45	1.94	35x35	1.75
470					30x50	2.14	35x40	1.96
560					30x60	2.45	35x45	2.16
680							35x55	2.52
820							35x60	2.72

Cap.(μF)	420Vdc							
	φ22		φ25		φ30		φ35	
82	22x25	0.79						
100	22x30	0.91						
120	22x30	0.99	25x25	0.96				
150	22x35	1.14	25x30	1.12				
180	22x45	1.34	25x35	1.28				
220	22x50	1.51	25x40	1.45	30x30	1.35		
270	22x60	1.74	25x45	1.64	30x35	1.54		
330			25x55	1.90	30x40	1.74		
390			25x60	2.09	30x45	1.93	35x35	1.74
470					30x55	2.24	35x40	1.95
560					30x60	2.44	35x45	2.15
680							35x55	2.51

Cap.(μF)	450Vdc							
	φ22		φ25		φ30		φ35	
82	22x25	0.77						
100	22x30	0.89						
120	22x30	0.94	25x25	0.93				
150	22x40	1.17	25x30	1.10	30x25	1.06		
180	22x45	1.32	25x35	1.25	30x30	1.24		
220	22x50	1.49	25x40	1.42	30x30	1.31	35x25	1.23
270	22x60	1.73	25x45	1.59	30x35	1.50	35x30	1.45
330			25x55	1.88	30x40	1.70	35x35	1.65
390					30x45	1.88	35x35	1.69
470					30x55	2.21	35x40	1.90
560					30x60	2.39	35x50	2.26
680							35x55	2.47

THK series

125°C 2000 時間品
Load Life : 125°C 2000 hours



◆規格表 / SPECIFICATIONS

項目 Item	特性 Characteristics						
カテゴリ温度範囲 Category Temperature Range	-25~+125°C						
定格電圧範囲 Rated Voltage Range	400~450Vdc						
静電容量許容差 Capacitance Tolerance	±20% (20°C, 120Hz)						
漏れ電流 Leakage Current (MAX)	$I=5\sqrt{CV}$ (定格電圧印加5分後) $I=5\sqrt{CV}$ (After 5 minutes application of rated voltage) I=漏れ電流(μA) C=静電容量(μF) V=定格電圧(Vdc) Leakage Current Capacitance Rated Voltage						
損失角の正接 (tan δ) Dissipation Factor (MAX)	<table border="1"> <tr> <td>定格電圧 (Vdc) Rated Voltage</td> <td>400~ 450</td> <td>(20°C, 120Hz)</td> </tr> <tr> <td>tan δ</td> <td>0.25</td> <td></td> </tr> </table>	定格電圧 (Vdc) Rated Voltage	400~ 450	(20°C, 120Hz)	tan δ	0.25	
定格電圧 (Vdc) Rated Voltage	400~ 450	(20°C, 120Hz)					
tan δ	0.25						
耐久性 Endurance	125°C中で2000時間定格電圧(リップル重畳)印加後、下記項目を満足すること。 After applying rated voltage with rated ripple current for 2000 hours at 125°C, the capacitors shall meet the following requirements. <table border="1"> <tr> <td>静電容量変化率 Capacitance Change</td> <td>初期値の ±20% 以内 Within ±20% of the initial value.</td> </tr> <tr> <td>損失角の正接 Dissipation Factor</td> <td>規格値の 200% 以下 Not more than 200% of the specified value.</td> </tr> <tr> <td>漏れ電流 Leakage Current</td> <td>規格値以下 Not more than the specified value.</td> </tr> </table>	静電容量変化率 Capacitance Change	初期値の ±20% 以内 Within ±20% of the initial value.	損失角の正接 Dissipation Factor	規格値の 200% 以下 Not more than 200% of the specified value.	漏れ電流 Leakage Current	規格値以下 Not more than the specified value.
静電容量変化率 Capacitance Change	初期値の ±20% 以内 Within ±20% of the initial value.						
損失角の正接 Dissipation Factor	規格値の 200% 以下 Not more than 200% of the specified value.						
漏れ電流 Leakage Current	規格値以下 Not more than the specified value.						
低温特性 Low Temperature Stability (インピーダンス比) Impedance Ratio (MAX)	<table border="1"> <tr> <td>定格電圧 (Vdc) Rated Voltage</td> <td>400~ 450</td> <td>(120Hz)</td> </tr> <tr> <td>Z(-25°C)/Z(+20°C)</td> <td>10</td> <td></td> </tr> </table>	定格電圧 (Vdc) Rated Voltage	400~ 450	(120Hz)	Z(-25°C)/Z(+20°C)	10	
定格電圧 (Vdc) Rated Voltage	400~ 450	(120Hz)					
Z(-25°C)/Z(+20°C)	10						

◆呼称方法 / PART NUMBER

□□□
THK
□□□□□
M
□□□
□□
D x L
 Rated Voltage Series Capacitance Capacitance Tolerance Option Terminal Code Case Size

◆リップル電流補正係数 /
MULTIPLIER FOR RIPPLE CURRENT

周波数 (Hz) Frequency	60 (50)	120 (100)	300	500	1k	10k ≤
係数 Coefficient	0.80	1.00	1.15	1.20	1.25	1.40

◆副記号 / OPTION

EFC : PET スリーブ、底板なし
PET Sleeve without plate

◆端子記号 / Terminal Code

SN : 標準端子 Standard Terminal

その他の形状は端子形状一覧をご確認ください。
For other type, please refer to the list of terminal type.

◆寸法図/DIMENSIONS

●SN[4mm]端子タイプ
SN[4mm]terminal type

端子記号 : SN(錫メッキ)
Terminal code : SN(Tin plating)

(mm)

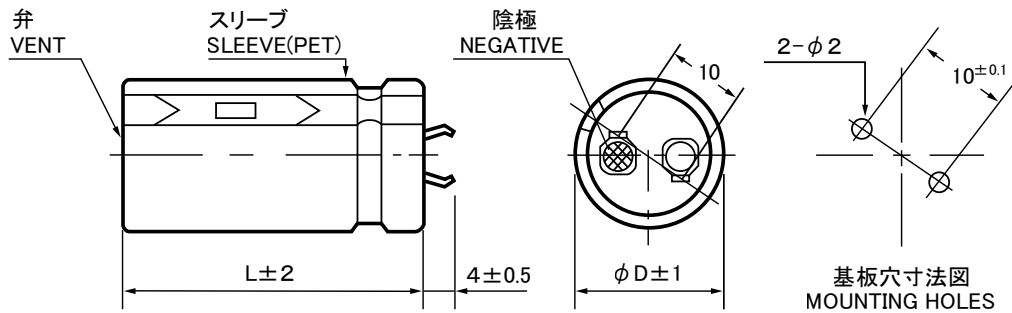

基板穴寸法図
MOUNTING HOLES

◆標準品一覧表/STANDARD SIZE

Cap.(μ F)	400Vdc							
	ϕ 22		ϕ 25		ϕ 30		ϕ 35	
100	22x25	0.84						
120	22x30	0.97						
150	22x30	1.06	25x25	1.03				
180	22x35	1.22	25x30	1.19				
220	22x40	1.38	25x35	1.37	30x25	1.22		
270	22x50	1.64	25x40	1.56	30x30	1.43	35x25	1.33
330	22x55	1.81	25x45	1.76	30x35	1.64	35x30	1.56
390			25x50	1.94	30x40	1.84	35x30	1.59
470			25x60	2.25	30x45	2.06	35x35	1.82
560					30x50	2.27	35x40	2.05
680					30x60	2.62	35x45	2.26
820							35x55	2.66
1000							35x60	2.86

Cap.(μ F)	420Vdc							
	ϕ 22		ϕ 25		ϕ 30		ϕ 35	
100	22x25	0.84						
120	22x30	0.97						
150	22x30	1.04	25x25	1.02				
180	22x35	1.21	25x30	1.19				
220	22x40	1.36	25x35	1.37	30x25	1.20		
270	22x50	1.64	25x40	1.56	30x30	1.43	35x25	1.32
330	22x60	1.90	25x45	1.75	30x35	1.64	35x30	1.54
390			25x55	2.03	30x40	1.84	35x30	1.58
470			25x60	2.22	30x45	2.05	35x35	1.81
560					30x50	2.25	35x40	2.03
680					30x60	2.61	35x45	2.24
820							35x55	2.64

Cap.(μ F)	450Vdc							
	ϕ 22		ϕ 25		ϕ 30		ϕ 35	
100	22x25	0.83						
120	22x30	0.95	25x25	0.93				
150	22x35	1.11	25x30	1.08				
180	22x40	1.25	25x30	1.16	30x25	1.12		
220	22x45	1.42	25x35	1.34	30x30	1.32		
270	22x50	1.57	25x40	1.51	30x35	1.51	35x25	1.28
330	22x60	1.83	25x50	1.80	30x35	1.57	35x30	1.52
390			25x55	1.98	30x40	1.77	35x35	1.73
470					30x50	2.11	35x40	1.95
560					30x55	2.32	35x45	2.16
680							35x50	2.37
820							35x55	2.56

ケースサイズ Case Size ϕ D x L(mm) \rightarrow
140 リプル電流 Ripple Current (A.r.m.s./120Hz,125°C) \rightarrow

USG series

85°C 3000 時間 標準品
Load Life : 85°C 3000 hours, Standard



◆規格表 / SPECIFICATIONS

項目 Item	特性 Characteristics																				
カテゴリ温度範囲 Category Temperature Range	-40~+85°C	-25~+85°C																			
定格電圧範囲 Rated Voltage Range	10~250Vdc	400~450Vdc																			
静電容量許容差 Capacitance Tolerance	±20% (20°C, 120Hz)																				
漏れ電流 Leakage Current (MAX)	$I=3\sqrt{CV}$ (定格電圧印加5分後) $I=3\sqrt{CV}$ (After 5 minutes application of rated voltage) I=漏れ電流 (µA) C=静電容量 (µF) V=定格電圧 (Vdc) Leakage Current Capacitance Rated Voltage																				
損失角の正接 (tan δ) Dissipation Factor (MAX)	<table border="1"> <tr> <td>定格電圧 (Vdc) Rated Voltage</td> <td>10</td> <td>16</td> <td>25</td> <td>35</td> <td>50</td> <td>63</td> <td>80</td> <td>100~450</td> <td rowspan="2">(20°C, 120Hz)</td> </tr> <tr> <td>tan δ</td> <td>0.55</td> <td>0.50</td> <td>0.45</td> <td>0.40</td> <td>0.35</td> <td>0.30</td> <td>0.25</td> <td>0.20</td> </tr> </table>		定格電圧 (Vdc) Rated Voltage	10	16	25	35	50	63	80	100~450	(20°C, 120Hz)	tan δ	0.55	0.50	0.45	0.40	0.35	0.30	0.25	0.20
定格電圧 (Vdc) Rated Voltage	10	16	25	35	50	63	80	100~450	(20°C, 120Hz)												
tan δ	0.55	0.50	0.45	0.40	0.35	0.30	0.25	0.20													
耐久性 Endurance	85°C中で3000時間定格電圧(リップル重畳)印加後、下記項目を満足すること。 After applying rated voltage with rated ripple current for 3000 hours at 85°C, the capacitors shall meet the following requirements.																				
	<table border="1"> <tr> <td>静電容量変化率 Capacitance Change</td> <td colspan="2">初期値の ±20% 以内 Within ±20% of the initial value.</td> </tr> <tr> <td>損失角の正接 Dissipation Factor</td> <td colspan="2">規格値の 200% 以下 Not more than 200% of the specified value.</td> </tr> <tr> <td>漏れ電流 Leakage Current</td> <td colspan="2">規格値以下 Not more than the specified value.</td> </tr> </table>		静電容量変化率 Capacitance Change	初期値の ±20% 以内 Within ±20% of the initial value.		損失角の正接 Dissipation Factor	規格値の 200% 以下 Not more than 200% of the specified value.		漏れ電流 Leakage Current	規格値以下 Not more than the specified value.											
静電容量変化率 Capacitance Change	初期値の ±20% 以内 Within ±20% of the initial value.																				
損失角の正接 Dissipation Factor	規格値の 200% 以下 Not more than 200% of the specified value.																				
漏れ電流 Leakage Current	規格値以下 Not more than the specified value.																				
低温特性 Low Temperature Stability (インピーダンス比) Impedance Ratio (MAX)	<table border="1"> <tr> <td>定格電圧 (Vdc) Rated Voltage</td> <td>10~100</td> <td>160~250</td> <td>400</td> <td>420~450</td> <td rowspan="3">(120Hz)</td> </tr> <tr> <td>Z(-25°C)/Z(+20°C)</td> <td>3</td> <td>4</td> <td>8</td> <td>12</td> </tr> <tr> <td>Z(-40°C)/Z(+20°C)</td> <td>12</td> <td>12</td> <td>-</td> <td>-</td> </tr> </table>		定格電圧 (Vdc) Rated Voltage	10~100	160~250	400	420~450	(120Hz)	Z(-25°C)/Z(+20°C)	3	4	8	12	Z(-40°C)/Z(+20°C)	12	12	-	-			
定格電圧 (Vdc) Rated Voltage	10~100	160~250	400	420~450	(120Hz)																
Z(-25°C)/Z(+20°C)	3	4	8	12																	
Z(-40°C)/Z(+20°C)	12	12	-	-																	

◆呼称方法 / PART NUMBER

USG M D x L
 定格電圧 Rated Voltage シリーズ名 Series 静電容量 Capacitance 静電容量許容差 Capacitance Tolerance 副記号 Option 端子記号 Terminal Code ケースサイズ Case Size

◆リップル電流補正係数 / MULTIPLIER FOR RIPPLE CURRENT

周波数 (Hz) Frequency	60 (50)	120 (100)	300	500	1k	10k ≤
10~100Vdc	0.90	1.00	1.03	1.05	1.10	1.15
160~250Vdc	0.80	1.00	1.15	1.20	1.30	1.50
400~450Vdc	0.80	1.00	1.15	1.20	1.25	1.40

◆副記号 / OPTION

EFC : PET スリーブ、底板なし
PET Sleeve without plate

◆端子記号 / Terminal Code

SN : 標準端子 Standard Terminal

その他の形状は端子形状一覧をご確認ください。
For other type, please refer to the list of terminal type.

◆寸法図／DIMENSIONS

●SN[4(3.5)mm]端子タイプ
SN[4(3.5)mm]terminal type

端子記号 : SN(錫メッキ)
Terminal code : SN(Tin plating)

(mm)

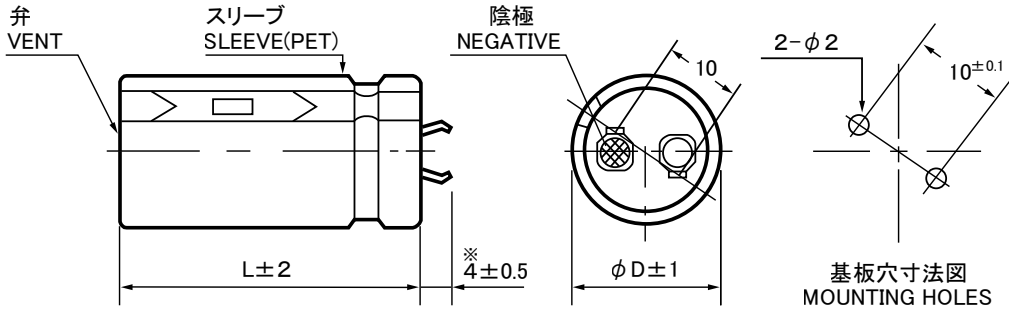

基板穴寸法図
MOUNTING HOLES

※ 但し φ 35は3.5±0.5
For φ 35, 3.5±0.5

◆標準品一覧表／STANDARD SIZE

Cap. (μF)	10Vdc					16Vdc										
	φ 20	φ 22	φ 25	φ 30	φ 35	φ 20	φ 22	φ 25	φ 30	φ 35						
8200						20x25	2.56									
10000	20x25	2.22				20x30	2.85	22x25	2.85							
12000	20x30	2.44	22x25	2.41		20x35	3.20	22x30	3.20							
15000	20x35	2.90	22x30	2.88	25x25	2.88		20x40	3.70	22x35	3.70	25x25	3.70			
18000	20x40	3.31	22x35	3.22	25x30	3.08		22x40	3.98	25x30	3.98					
22000		22x40	3.79	25x30	3.66	30x25	3.58		22x45	4.52	25x35	4.52	30x25	4.52		
27000		22x45	4.04	25x35	4.04	30x30	3.99		22x50	4.98	25x40	4.98	30x30	4.98		
33000		22x50	4.58	25x40	4.56	30x30	4.58			25x45	5.49	30x35	5.49	35x30	5.49	
39000				25x45	5.29	30x35	5.21	35x30	5.05		25x50	6.11	30x40	6.11	35x35	6.11
47000				25x50	5.78	30x40	5.78	35x35	5.55				30x45	6.80	35x35	6.80
56000						30x45	6.59	35x35	6.40				30x50	7.62	35x40	7.62
68000						30x50	7.50	35x40	7.48						35x45	8.45
82000								35x50	8.50						35x50	9.14

Cap. (μF)	25Vdc					35Vdc										
	φ 20	φ 22	φ 25	φ 30	φ 35	φ 20	φ 22	φ 25	φ 30	φ 35						
3300						20x25	2.14									
3900						20x30	2.28									
4700						20x35	2.46	22x25	2.46							
5600	20x25	2.33				20x40	2.79	22x30	2.79	25x25	2.79					
6800	20x30	2.56	22x25	2.56			22x35	2.89	25x30	2.89						
8200	20x35	2.91	22x30	2.91			22x40	3.47	25x30	3.47	30x25	3.47				
10000	20x40	3.18	22x35	3.18	25x25	3.18		22x45	3.59	25x35	3.59	30x30	3.59			
12000		22x40	3.53	25x30	3.53			22x50	4.51	25x40	4.51	30x30	4.51			
15000		22x45	4.08	25x35	4.08	30x25	4.08			25x45	4.80	30x35	4.80	35x30	4.80	
18000		22x50	4.68	25x40	4.68	30x30	4.68					30x40	5.70	35x35	5.70	
22000			25x45	5.19	30x35	5.19	35x30	5.19				30x45	6.38	35x40	6.38	
27000			25x50	6.02	30x40	6.02	35x35	6.02						35x45	6.90	
33000					30x45	6.75	35x40	6.75						35x50	7.49	
39000					30x50	7.56	35x45	7.56								
47000						35x50	8.30									

Cap. (μF)	50Vdc					63Vdc										
	φ 20	φ 22	φ 25	φ 30	φ 35	φ 20	φ 22	φ 25	φ 30	φ 35						
1500						20x25	1.69									
1800						20x30	2.04	22x25	2.04							
2200	20x25	2.07				20x35	2.40	22x30	2.40							
2700	20x30	2.21	22x25	2.21		20x40	2.52	22x35	2.52	25x25	2.52					
3300	20x35	2.41	22x30	2.41			22x40	2.69	25x30	2.69						
3900	20x40	2.72	22x30	2.72	25x25	2.72		22x45	3.10	25x35	3.10	30x25	3.10			
4700		22x35	3.01	25x30	3.01			22x50	3.49	25x40	3.49	30x30	3.49			
5600		22x40	3.43	25x35	3.43	30x25	3.43			25x45	3.81	30x35	3.81			
6800		22x45	3.94	25x35	3.94	30x30	3.94			25x50	4.41	30x40	4.41	35x30	4.41	
8200			25x40	4.37	30x35	4.37						30x45	4.90	35x35	4.90	
10000			25x50	5.02	30x40	5.02	35x30	5.02				30x50	5.49	35x40	5.49	
12000					30x45	5.60	35x35	5.60						35x45	6.30	
15000					30x50	6.44	35x40	6.44								
18000						35x45	6.71									

ケースサイズ Case Size φD×L(mm) → ↑
リップル電流 Ripple Current (A.r.m.s./120Hz,85°C) → ↑

◆標準品一覧表／STANDARD SIZE

Cap. (μ F)	80Vdc					100Vdc									
	ϕ 20	ϕ 22	ϕ 25	ϕ 30	ϕ 35	ϕ 20	ϕ 22	ϕ 25	ϕ 30	ϕ 35					
680						20x25	1.66								
820						20x30	1.86	22x25	1.86						
1000	20x25	1.56				20x30	2.02	22x30	2.02						
1200	20x30	1.80	22x25	1.80		20x35	2.12	22x30	2.12	25x25	2.12				
1500	20x30	2.10	22x30	2.10		20x40	2.45	22x35	2.45	25x30	2.45				
1800	20x35	2.30	22x30	2.30	25x25	2.30		22x40	2.77	25x30	2.77	30x25	2.77		
2200	20x40	2.53	22x35	2.53	25x30	2.53		22x45	3.12	25x35	3.12	30x30	3.12		
2700			22x40	2.93	25x35	2.93	30x25	2.93		25x40	3.61	30x30	3.61		
3300			22x45	3.25	25x35	3.25	30x30	3.25		25x50	4.06	30x35	4.06	35x30	4.06
3900					25x40	3.62	30x35	3.62				30x40	4.60	35x35	4.60
4700					25x45	4.28	30x40	4.28	35x30	4.28		30x45	5.13	35x40	5.13
5600							30x45	4.55	35x35	4.55				35x45	5.75
6800							30x45	5.83	35x40	5.83				35x50	6.01
8200									35x45	6.40					
10000									35x50	7.03					

Cap. (μ F)	160Vdc					180Vdc											
	ϕ 20	ϕ 22	ϕ 25	ϕ 30	ϕ 35	ϕ 20	ϕ 22	ϕ 25	ϕ 30	ϕ 35							
390	20x25	1.19				20x25	1.84										
470	20x30	1.76	22x25	1.76		20x30	2.08	22x25	2.08								
560	20x30	2.25	22x25	2.25		20x35	2.25	22x30	2.25								
680	20x35	2.50	22x30	2.50	25x25	2.50		20x40	2.50	22x35	2.50	25x25	2.50				
820	20x40	2.75	22x35	2.75	25x30	2.75		20x45	2.75	22x40	2.75	25x30	2.75				
1000			22x40	3.00	25x30	3.00	30x25	3.00		22x45	3.00	25x35	3.00	30x25	3.00		
1200			22x45	3.25	25x35	3.25	30x30	3.25		22x50	3.31	25x40	3.31	30x30	3.31	35x25	3.31
1500					25x45	3.73	30x35	3.73			25x50	3.83	30x35	3.83	35x30	3.83	
1800					25x50	4.20	30x35	4.20	35x30	4.20				30x40	4.32	35x35	4.32
2200							30x45	4.78	35x35	4.78				30x50	4.92	35x40	4.92
2700									30x50	5.45	35x40	5.45				35x45	5.52
3300											35x45	5.75					

Cap. (μ F)	200Vdc					220Vdc											
	ϕ 20	ϕ 22	ϕ 25	ϕ 30	ϕ 35	ϕ 20	ϕ 22	ϕ 25	ϕ 30	ϕ 35							
270						20x25	1.42										
330	20x25	1.44				20x30	1.58	22x25	1.58								
390	20x30	1.68	22x25	1.68		20x35	1.75	22x30	1.75								
470	20x35	1.93	22x30	1.93	25x25	1.93		20x35	1.99	22x30	1.99	25x25	1.99				
560	20x35	2.43	22x30	2.43	25x25	2.43		20x40	2.28	22x35	2.28	25x30	2.28				
680	20x40	2.68	22x35	2.68	25x30	2.68	30x25	2.68		22x40	2.46	25x30	2.46	30x25	2.46		
820			22x40	2.93	25x30	2.93	30x25	2.93		22x45	2.81	25x35	2.81	30x30	2.81		
1000			22x45	3.25	25x35	3.25	30x30	3.25	35x25	3.25		25x45	3.29	30x30	3.29		
1200					25x45	3.50	30x35	3.50	35x30	3.50		25x50	3.60	30x35	3.60	35x30	3.60
1500					25x50	3.87	30x40	3.87	35x30	3.87				30x45	3.92	35x35	3.92
1800							30x45	4.32	35x35	4.32				30x50	4.30	35x40	4.30
2200								30x50	4.92	35x40	4.92					35x50	4.95
2700										35x50	5.45						

ケースサイズ Case Size $\phi D \times L$ (mm) \rightarrow ↑
 リプル電流 Ripple Current (A.r.m.s./120Hz,85°C) \rightarrow ↑

◆標準品一覧表／STANDARD SIZE

Cap. (μ F)	250Vdc					400Vdc									
	ϕ 20	ϕ 22	ϕ 25	ϕ 30	ϕ 35	ϕ 20	ϕ 22	ϕ 25	ϕ 30	ϕ 35					
82						20x25	0.80								
100						20x30	0.94	22x25	0.94						
120						20x30	1.08	22x25	1.08						
150						20x35	1.21	22x30	1.21	25x25	1.21				
180						20x40	1.45	22x35	1.45	25x25	1.45				
220	20x25	1.23						22x40	1.58	25x30	1.58	30x25	1.58		
270	20x30	1.31	22x25	1.31				22x45	1.67	25x35	1.67	30x25	1.67		
330	20x30	1.75	22x25	1.75				22x50	1.90	25x40	1.90	30x30	1.90	35x25	1.90
390	20x35	1.91	22x30	1.91	25x25	1.91				25x45	2.13	30x35	2.13	35x30	2.13
470	20x40	2.11	22x35	2.11	25x25	2.11				25x50	2.39	30x40	2.39	35x30	2.39
560			22x40	2.25	25x30	2.25	30x25	2.25				30x45	2.69	35x35	2.69
680			22x45	2.50	25x35	2.50	30x30	2.50						35x40	2.96
820					25x40	2.77	30x30	2.77	35x25	2.77				35x50	3.25
1000					25x45	3.32	30x35	3.32	35x30	3.32					
1200							30x40	3.84	35x35	3.84					
1500							30x50	4.25	35x40	4.25					
1800									35x45	4.55					

Cap. (μ F)	420Vdc					450Vdc						
	ϕ 20	ϕ 22	ϕ 25	ϕ 30	ϕ 35	ϕ 20	ϕ 22	ϕ 25	ϕ 30	ϕ 35		
68						20x25	0.66					
82	20x25	0.83				20x25	0.83					
100	20x30	0.97	22x25	0.97		20x30	0.93	22x25	0.93			
120	20x30	1.08	22x25	1.08		20x35	1.04	22x30	1.04	25x25	1.04	
150	20x35	1.30	22x30	1.30	25x25	1.30						
180	20x40	1.48	22x35	1.48	25x30	1.48						
220			22x40	1.65	25x35	1.65	30x25	1.65				
270			22x50	1.94	25x35	1.94	30x30	1.94				
330					25x45	2.17	30x35	2.17	35x30	2.17		
390					25x50	2.27	30x35	2.27	35x30	2.27		
470							30x40	2.61	35x35	2.61		
560							30x50	2.82	35x40	2.82		
680									35x45	3.11		

ケースサイズ Case Size ϕ D × L (mm) \longrightarrow \uparrow
 リプル電流 Ripple Current (A.r.m.s./120Hz, 85°C) \longrightarrow \uparrow

USK series

85°C 3000時間 超小形化品
Load Life : 85°C 3000 hours, Ultra Miniaturized



◆規格表/SPECIFICATIONS

項目 Item	特性 Characteristics																				
カテゴリ温度範囲 Category Temperature Range	-40~+85°C	-25~+85°C																			
定格電圧範囲 Rated Voltage Range	16~250Vdc	400~500Vdc																			
静電容量許容差 Capacitance Tolerance	±20% (20°C, 120Hz)																				
漏れ電流 Leakage Current (MAX)	$I=3\sqrt{CV}$ (定格電圧印加5分後) $I=3\sqrt{CV}$ (After 5 minutes application of rated voltage) I=漏れ電流 (µA) C=静電容量 (µF) V=定格電圧 (Vdc) Leakage Current Capacitance Rated Voltage																				
損失角の正接 (tan δ) Dissipation Factor (MAX)	<table border="1"> <tr> <td>定格電圧 (Vdc) Rated Voltage</td> <td>16</td> <td>25</td> <td>35</td> <td>50</td> <td>63</td> <td>80~100</td> <td>160~450</td> <td>475, 500</td> <td rowspan="2">(20°C, 120Hz)</td> </tr> <tr> <td>tan δ</td> <td>0.50</td> <td>0.45</td> <td>0.40</td> <td>0.35</td> <td>0.30</td> <td>0.25</td> <td>0.20</td> <td>0.25</td> </tr> </table>		定格電圧 (Vdc) Rated Voltage	16	25	35	50	63	80~100	160~450	475, 500	(20°C, 120Hz)	tan δ	0.50	0.45	0.40	0.35	0.30	0.25	0.20	0.25
定格電圧 (Vdc) Rated Voltage	16	25	35	50	63	80~100	160~450	475, 500	(20°C, 120Hz)												
tan δ	0.50	0.45	0.40	0.35	0.30	0.25	0.20	0.25													
耐久性 Endurance	85°C中で3000時間定格電圧(リップル重畳)印加後、下記項目を満足すること。 After applying rated voltage with rated ripple current for 3000 hours at 85°C, the capacitors shall meet the following requirements.																				
	<table border="1"> <tr> <td>静電容量変化率 Capacitance Change</td> <td colspan="2">初期値の ±20% 以内 Within ±20% of the initial value.</td> </tr> <tr> <td>損失角の正接 Dissipation Factor</td> <td colspan="2">規格値の 200% 以下 Not more than 200% of the specified value.</td> </tr> <tr> <td>漏れ電流 Leakage Current</td> <td colspan="2">規格値以下 Not more than the specified value.</td> </tr> </table>		静電容量変化率 Capacitance Change	初期値の ±20% 以内 Within ±20% of the initial value.		損失角の正接 Dissipation Factor	規格値の 200% 以下 Not more than 200% of the specified value.		漏れ電流 Leakage Current	規格値以下 Not more than the specified value.											
静電容量変化率 Capacitance Change	初期値の ±20% 以内 Within ±20% of the initial value.																				
損失角の正接 Dissipation Factor	規格値の 200% 以下 Not more than 200% of the specified value.																				
漏れ電流 Leakage Current	規格値以下 Not more than the specified value.																				
低温特性 Low Temperature Stability (インピーダンス比) Impedance Ratio (MAX)	<table border="1"> <tr> <td>定格電圧 (Vdc) Rated Voltage</td> <td>16~100</td> <td>160~250</td> <td>400~450</td> <td>475, 500</td> <td rowspan="3">(120Hz)</td> </tr> <tr> <td>Z(-25°C)/Z(+20°C)</td> <td>3</td> <td>4</td> <td>8</td> <td>10</td> </tr> <tr> <td>Z(-40°C)/Z(+20°C)</td> <td>12</td> <td>12</td> <td>-</td> <td>-</td> </tr> </table>		定格電圧 (Vdc) Rated Voltage	16~100	160~250	400~450	475, 500	(120Hz)	Z(-25°C)/Z(+20°C)	3	4	8	10	Z(-40°C)/Z(+20°C)	12	12	-	-			
定格電圧 (Vdc) Rated Voltage	16~100	160~250	400~450	475, 500	(120Hz)																
Z(-25°C)/Z(+20°C)	3	4	8	10																	
Z(-40°C)/Z(+20°C)	12	12	-	-																	

◆呼称方法/PART NUMBER

USK M D x L
 定格電圧 Rated Voltage シリーズ名 Series 静電容量 Capacitance 静電容量許容差 Capacitance Tolerance 副記号 Option 端子記号 Terminal Code ケースサイズ Case Size

◆リップル電流補正係数/
MULTIPLIER FOR RIPPLE CURRENT

周波数 (Hz) Frequency	60 (50)	120 (100)	300	500	1k	10k ≤
16~100Vdc	0.90	1.00	1.03	1.05	1.10	1.15
160~250Vdc	0.80	1.00	1.15	1.20	1.30	1.50
400~500Vdc	0.80	1.00	1.15	1.20	1.25	1.40

◆副記号/OPTION

EFC : PET スリーブ、底板なし
PET Sleeve without plate

◆端子記号/Terminal Code

SN : 標準端子 Standard Terminal

その他の形状は端子形状一覧をご確認ください。
For other type, please refer to the list of terminal type.

◆寸法図/DIMENSIONS

●SN[4mm]端子タイプ
SN[4mm]terminal type

端子記号 : SN(錫メッキ)
Terminal code : SN(Tin plating)

(mm)

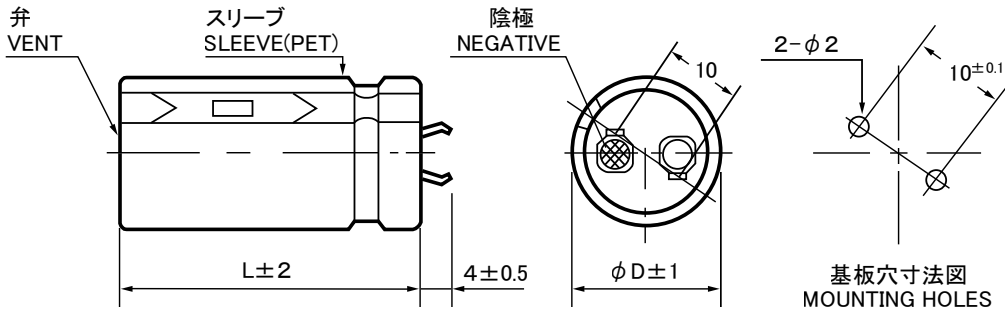

◆標準品一覧表/STANDARD SIZE

Cap. (μ F)	16Vdc					25Vdc								
	ϕ 22	ϕ 25	ϕ 30	ϕ 35		ϕ 22	ϕ 25	ϕ 30	ϕ 35					
10000						22x25	4.09							
12000						22x30	4.82	25x25	4.16					
15000	22x25	4.12				22x35	5.43	25x30	4.88					
18000	22x30	4.86	25x25	4.15		22x40	5.98	25x30	4.70					
22000	22x35	5.48	25x30	4.90		22x45	6.47	25x35	5.32	30x30	7.36			
27000	22x40	6.02	25x30	4.69		22x50	6.88	25x40	5.83	30x30	7.21			
33000	22x45	6.50	25x35	5.29	30x30	7.43	22x60	7.75	25x50	6.91	30x35	8.11	35x30	7.19
39000	22x50	6.94	25x40	5.85	30x30	7.30			25x55	7.28	30x40	8.91	35x35	8.16
47000	22x60	7.83	25x50	6.97	30x35	8.20	35x30	7.25			30x45	9.62	35x40	8.95
56000			25x55	7.32	30x40	9.00	35x35	8.22			30x55	10.95	35x45	9.64
68000					30x50	10.49	35x40	9.00					35x50	10.18
82000					30x55	11.02	35x45	9.66					35x60	11.43

Cap. (μ F)	35Vdc					50Vdc								
	ϕ 22	ϕ 25	ϕ 30	ϕ 35		ϕ 22	ϕ 25	ϕ 30	ϕ 35					
3900						22x25	3.52							
4700						22x30	4.12	25x25	3.63					
5600						22x35	4.67	25x30	4.28					
6800	22x25	3.99				22x40	5.18	25x30	4.18	30x25	5.40			
8200	22x30	4.69	25x25	4.05		22x45	5.65	25x35	4.75	30x30	6.28			
10000	22x35	5.29	25x30	4.77		22x50	6.09	25x40	5.25	30x30	6.30	35x25	5.43	
12000	22x40	5.84	25x30	4.60		22x60	6.90	25x45	5.69	30x35	7.11	35x30	6.43	
15000	22x45	6.31	25x35	5.19	30x30	7.16			25x55	6.57	30x40	7.83	35x35	7.25
18000	22x50	6.77	25x40	5.73	30x35	8.06					30x50	9.14	35x40	8.00
22000	22x60	7.61	25x50	6.79	30x35	7.95	35x30	7.05			30x55	9.71	35x45	8.63
27000			25x60	7.65	30x45	9.53	35x35	7.94					35x50	9.18
33000					30x50	10.14	35x40	8.70					35x60	10.32
39000					30x55	10.72	35x45	9.39						
47000							35x50	9.99						
56000							35x60	11.20						

Cap. (μ F)	63Vdc					80Vdc										
	ϕ 22	ϕ 25	ϕ 30	ϕ 35		ϕ 22	ϕ 25	ϕ 30	ϕ 35							
1800						22x25	3.09									
2200						22x30	3.60									
2700	22x25	3.24				22x30	3.69	25x25	3.29							
3300	22x30	3.78				22x35	4.19	25x30	3.87							
3900	22x30	3.82	25x25	3.38		22x40	4.65	25x35	4.39	30x25	4.82					
4700	22x35	4.34	25x30	3.98		22x45	5.11	25x40	4.87	30x30	5.59	35x25	5.03			
5600	22x40	4.82	25x35	4.52	30x25	5.00	22x55	5.88	25x45	5.32	30x35	6.30	35x30	5.89		
6800	22x45	5.28	25x40	5.01	30x30	5.82	35x25	5.18	22x60	6.29	25x50	5.73	30x40	6.99	35x30	5.88
8200	22x55	6.08	25x45	5.46	30x35	6.56	35x30	6.08			25x55	6.12	30x45	7.65	35x35	6.66
10000			25x50	5.86	30x40	7.27	35x30	6.01					30x50	8.28	35x40	7.36
12000			25x60	6.66	30x45	7.93	35x35	6.82					30x60	9.32	35x45	7.99
15000					30x50	8.57	35x40	7.51							35x55	9.17
18000					30x60	9.64	35x50	8.84								
22000							35x55	9.36								

ケースサイズ Case Size ϕ D×L(mm) \rightarrow
リップル電流 Ripple Current (A.r.m.s./120Hz,85°C) \rightarrow

◆標準品一覧表 / STANDARD SIZE

Cap. (μ F)	100Vdc								160Vdc							
	ϕ 22		ϕ 25		ϕ 30		ϕ 35		ϕ 22		ϕ 25		ϕ 30		ϕ 35	
560									22x25	2.20						
680									22x30	2.56						
820									22x35	2.94	25x25	2.47				
1000									22x35	3.07	25x30	2.90				
1200	22x25	2.91							22x45	3.70	25x35	3.32	30x25	2.64		
1500	22x30	3.40							22x50	4.14	25x40	3.75	30x30	3.12	35x25	2.63
1800	22x30	3.49	25x25	3.14					22x60	4.76	25x45	4.16	30x35	3.58	35x30	3.16
2200	22x35	3.97	25x30	3.69							25x55	4.87	30x40	4.00	35x35	3.63
2700	22x40	4.43	25x35	4.18	30x25	4.57							30x45	4.42	35x40	4.04
3300	22x50	5.20	25x40	4.65	30x30	5.31	35x25	4.79					30x55	5.18	35x45	4.41
3900	22x55	5.61	25x45	5.08	30x35	5.98	35x30	5.60					30x60	5.58	35x50	4.77
4700			25x50	5.50	30x40	6.64	35x30	5.63							35x55	5.13
5600			25x60	6.24	30x45	7.27	35x35	6.37								
6800					30x50	7.89	35x40	7.05								
8200					30x60	8.90	35x50	8.26								
10000							35x55	8.81								

Cap. (μ F)	180Vdc								200Vdc							
	ϕ 22		ϕ 25		ϕ 30		ϕ 35		ϕ 22		ϕ 25		ϕ 30		ϕ 35	
470									22x25	2.12						
560	22x25	2.20							22x30	2.45	25x25	2.31				
680	22x30	2.57	25x25	2.40					22x35	2.81	25x30	2.68				
820	22x35	2.93	25x30	2.78					22x40	3.17	25x30	2.80	30x25	2.57		
1000	22x40	3.32	25x30	2.91	30x25	2.65			22x45	3.56	25x35	3.21	30x30	2.90		
1200	22x45	3.71	25x35	3.32	30x30	2.99			22x50	3.94	25x40	3.61	30x30	3.04	35x25	2.59
1500	22x55	4.36	25x40	3.76	30x30	3.13	35x25	2.63	22x60	4.58	25x50	4.30	30x35	3.49	35x30	3.09
1800	22x60	4.77	25x50	4.46	30x35	3.57	35x30	3.15			25x55	4.71	30x40	3.91	35x35	3.55
2200			25x55	4.89	30x40	4.02	35x35	3.61					30x50	4.69	35x40	3.96
2700					30x50	4.81	35x40	4.03					30x55	5.08	35x45	4.33
3300					30x55	5.21	35x45	4.39							35x55	5.11
3900							35x50	4.79							35x60	5.42
4700							35x60	5.52								

Cap. (μ F)	220Vdc								250Vdc							
	ϕ 22		ϕ 25		ϕ 30		ϕ 35		ϕ 22		ϕ 25		ϕ 30		ϕ 35	
390									22x25	2.02						
470	22x25	2.12							22x30	2.35	25x25	2.22				
560	22x30	2.46	25x25	2.31					22x35	2.68	25x30	2.57				
680	22x35	2.81	25x30	2.70					22x40	3.03	25x30	2.69	30x25	2.48		
820	22x40	3.18	25x35	3.06	30x25	2.56			22x45	3.39	25x35	3.08	30x30	2.85		
1000	22x45	3.56	25x35	3.21	30x30	2.95			22x55	3.95	25x40	3.47	30x30	2.96	35x25	2.53
1200	22x55	4.14	25x45	3.87	30x30	3.04	35x25	2.58	22x60	4.34	25x50	4.10	30x35	3.38	35x30	3.02
1500			25x55	4.54	30x40	3.88	35x30	3.06			25x60	4.76	30x40	3.81	35x35	3.45
1800					30x45	4.22	35x35	3.47					30x50	4.53	35x40	3.86
2200					30x55	4.95	35x45	4.30					30x60	5.19	35x45	4.22
2700							35x50	4.63							35x55	4.93
3300							35x60	5.35								

ケースサイズ Case Size ϕ D × L(mm) \longrightarrow \uparrow
 リプル電流 Ripple Current (A.r.m.s./120Hz,85°C) \longrightarrow \uparrow

◆標準品一覧表 / STANDARD SIZE

Cap. (μ F)	400Vdc								420Vdc							
	ϕ 22		ϕ 25		ϕ 30		ϕ 35		ϕ 22		ϕ 25		ϕ 30		ϕ 35	
150	22x25	1.40							22x25	1.42						
180	22x25	1.47							22x30	1.63	25x25	1.59				
	22x30	1.60														
220	22x30	1.74	25x25	1.68					22x30	1.72	25x25	1.67				
									22x35	1.87	25x30	1.84				
270	22x35	1.99	25x30	1.95					22x35	1.97	25x30	1.98	30x25	1.91		
									22x40	2.13						
330	22x40	2.26	25x35	2.23	30x25	1.98			22x45	2.41	25x35	2.27	30x25	1.98		
															30x30	2.22
390	22x45	2.51	25x35	2.34	30x30	2.30			22x50	2.67	25x40	2.54	30x30	2.31	35x25	2.10
	22x50	2.64	25x40	2.50												
470	22x55	2.92	25x40	2.63	30x30	2.39	35x25	2.12	22x55	2.89	25x45	2.82	30x35	2.63	35x30	2.47
	22x60	3.03	25x45	2.81	30x35	2.61										
560	22x60	3.17	25x50	3.12	30x35	2.75	35x30	2.50			25x50	3.08	30x40	2.95	35x30	2.54
			25x55	3.24	30x40	2.92					25x55	3.28			35x35	2.81
680			25x55	3.41	30x40	3.05	35x35	2.83			25x60	3.55	30x45	3.29	35x35	2.90
			25x60	3.58	30x45	3.25									30x50	3.47
820					30x50	3.57	35x40	3.17					30x50	3.64	35x40	3.25
													30x55	3.80	35x45	3.47
1000					30x60	4.12	35x45	3.62					30x60	4.13	35x45	3.57
							35x50	3.79							35x50	3.78
1200							35x55	4.09							35x55	4.15
															35x60	4.36

Cap. (μ F)	450Vdc								475Vdc							
	ϕ 22		ϕ 25		ϕ 30		ϕ 35		ϕ 22		ϕ 25		ϕ 30		ϕ 35	
100									22x25	1.11						
120	22x25	1.30							22x30	1.28						
150	22x25	1.41							22x35	1.48	25x25	1.38				
	22x30	1.53														
180	22x30	1.65	25x25	1.60					22x35	1.60	25x30	1.59				
220	22x35	1.89	25x30	1.85					22x45	1.89	25x35	1.82	30x25	1.70		
270	22x40	2.15	25x35	2.12	30x25	1.90			22x50	2.14	25x40	2.07	30x30	1.97	35x25	1.87
330	22x45	2.37	25x35	2.23	30x30	2.22	35x25	2.04	22x60	2.46	25x45	2.33	30x35	2.25	35x30	2.18
	22x50	2.51	25x40	2.41												
390	22x55	2.75	25x40	2.50	30x30	2.29	35x25	2.11			25x55	2.68	30x40	2.51	35x30	2.27
	22x60	2.86	25x45	2.67	30x35	2.51	35x30	2.39								
470	22x60	3.01	25x50	2.96	30x35	2.63	35x30	2.43			25x60	2.95	30x45	2.81	35x35	2.58
			25x55	3.09	30x40	2.82										
560			25x55	3.23	30x40	2.95	35x35	2.78					30x50	3.10	35x40	2.89
			25x60	3.40	30x45	3.13										
680					30x45	3.25	35x40	3.10					30x60	3.56	35x50	3.40
					30x50	3.46										
820					30x55	3.77	35x45	3.43							35x55	3.72
					30x60	3.97										
1000							35x50	3.79								
							35x55	4.01								
1200							35x60	4.40								

Cap. (μ F)	500Vdc							
	ϕ 22		ϕ 25		ϕ 30		ϕ 35	
100	22x25	1.12						
120	22x30	1.28	25x25	1.27				
150	22x35	1.49	25x30	1.48				
180	22x40	1.68	25x30	1.60				
220	22x45	1.91	25x40	1.93	30x25	1.70		
270	22x55	2.23	25x45	2.18	30x35	2.12	35x25	1.87
330			25x50	2.45	30x40	2.39	35x30	2.18
390			25x60	2.79	30x40	2.52	35x35	2.47
470					30x50	2.95	35x40	2.78
560					30x55	3.25	35x45	3.08
680							35x50	3.40
820							35x60	3.89

ケースサイズ Case Size ϕ D × L (mm) \longleftarrow
 リプル電流 Ripple Current (A.r.m.s./120Hz,85°C) \longleftarrow

VXH series

105°C 5000 時間 小形化品
Load Life : 105°C 5000 hours, Miniaturized



◆規格表 / SPECIFICATIONS

項目 Item	特性 Characteristics									
カテゴリ温度範囲 Category Temperature Range	-25~+105°C									
定格電圧範囲 Rated Voltage Range	200~500Vdc									
静電容量許容差 Capacitance Tolerance	±20% (20°C, 120Hz)									
漏れ電流 Leakage Current (MAX)	$I=3\sqrt{CV}$ (定格電圧印加5分後) $I=3\sqrt{CV}$ (After 5 minutes application of rated voltage) I=漏れ電流 (μA) C=静電容量 (μF) V=定格電圧 (Vdc) Leakage Current Capacitance Rated Voltage									
損失角の正接 (tan δ) Dissipation Factor (MAX)	<table border="1"> <tr> <td>定格電圧 (Vdc) Rated Voltage</td> <td>200~450</td> <td>475, 500</td> <td rowspan="2">(20°C, 120Hz)</td> </tr> <tr> <td>tan δ</td> <td>0.20</td> <td>0.25</td> </tr> </table>	定格電圧 (Vdc) Rated Voltage	200~450	475, 500	(20°C, 120Hz)	tan δ	0.20	0.25		
定格電圧 (Vdc) Rated Voltage	200~450	475, 500	(20°C, 120Hz)							
tan δ	0.20	0.25								
耐久性 Endurance	<p>105°C 中で5000時間定格電圧(リップル重畳)印加後、下記項目を満足すること。 After applying rated voltage with rated ripple current for 5000 hours at 105°C, the capacitors shall meet the following requirements.</p> <table border="1"> <tr> <td>静電容量変化率 Capacitance Change</td> <td>初期値の ±20% 以内 Within ±20% of the initial value.</td> </tr> <tr> <td>損失角の正接 Dissipation Factor</td> <td>規格値の 200% 以下 Not more than 200% of the specified value.</td> </tr> <tr> <td>漏れ電流 Leakage Current</td> <td>規格値以下 Not more than the specified value.</td> </tr> </table>	静電容量変化率 Capacitance Change	初期値の ±20% 以内 Within ±20% of the initial value.	損失角の正接 Dissipation Factor	規格値の 200% 以下 Not more than 200% of the specified value.	漏れ電流 Leakage Current	規格値以下 Not more than the specified value.			
静電容量変化率 Capacitance Change	初期値の ±20% 以内 Within ±20% of the initial value.									
損失角の正接 Dissipation Factor	規格値の 200% 以下 Not more than 200% of the specified value.									
漏れ電流 Leakage Current	規格値以下 Not more than the specified value.									
低温特性 Low Temperature Stability (インピーダンス比) Impedance Ratio (MAX)	<table border="1"> <tr> <td>定格電圧 (Vdc) Rated Voltage</td> <td>200~250</td> <td>315~450</td> <td>475, 500</td> <td rowspan="2">(120Hz)</td> </tr> <tr> <td>Z(-25°C)/Z(+20°C)</td> <td>3</td> <td>8</td> <td>10</td> </tr> </table>	定格電圧 (Vdc) Rated Voltage	200~250	315~450	475, 500	(120Hz)	Z(-25°C)/Z(+20°C)	3	8	10
定格電圧 (Vdc) Rated Voltage	200~250	315~450	475, 500	(120Hz)						
Z(-25°C)/Z(+20°C)	3	8	10							

◆呼称方法 / PART NUMBER

□□□
VXH
□□□□□
M
□□□
□□
D x L
 Rated Voltage Series Capacitance Capacitance Tolerance Option Terminal Code Case Size

◆リップル電流補正係数 /
MULTIPLIER FOR RIPPLE CURRENT

周波数 (Hz) Frequency	60 (50)	120 (100)	300	500	1k	10k ≤	
係数 Coefficient	200~250Vdc	0.80	1.00	1.15	1.20	1.30	1.50
	315~500Vdc	0.80	1.00	1.15	1.20	1.25	1.40

◆副記号 / OPTION

EFC : PET スリーブ、底板なし
PET Sleeve without plate

◆端子記号 / Terminal Code

SN : 標準端子 Standard Terminal

その他の形状は端子形状一覧をご確認ください。
For other type, please refer to the list of terminal type.

◆寸法図／DIMENSIONS

●SN[4(3.5)mm]端子タイプ
SN[4(3.5)mm]terminal type

端子記号 : SN(錫メッキ)
Terminal code : SN(Tin plating)

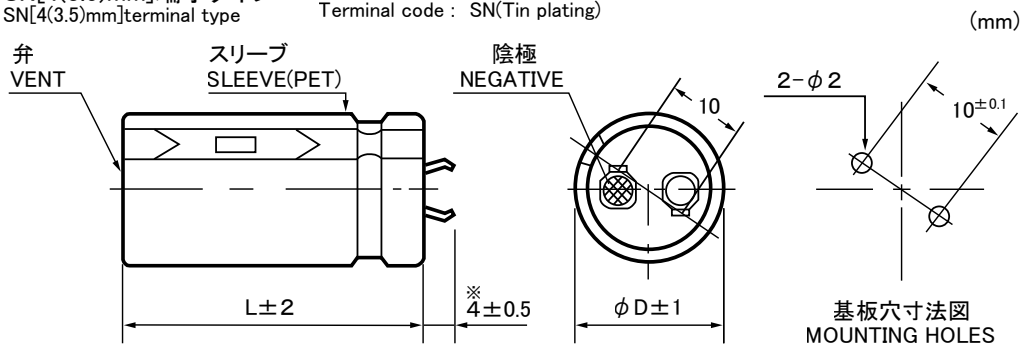

◆標準品一覧表／STANDARD SIZE

Cap. (μ F)	200Vdc								220Vdc							
	ϕ 22		ϕ 25		ϕ 30		ϕ 35		ϕ 22		ϕ 25		ϕ 30		ϕ 35	
270									22x25	1.33						
330	22x25	1.41							22x30	1.55						
390	22x30	1.63							22x30	1.63	25x25	1.50				
470	22x30	1.72	25x25	1.57					22x35	1.85	25x30	1.76				
560	22x35	1.95	25x30	1.84					22x40	2.08	25x30	1.83	30x25	1.64		
680	22x40	2.22	25x35	2.11	30x25	1.69			22x45	2.34	25x35	2.10	30x30	1.94		
820	22x50	2.60	25x40	2.37	30x30	2.01	35x25	1.68	22x55	2.73	25x40	2.35	30x30	1.99	35x25	1.89
1000	22x60	3.00	25x45	2.63	30x35	2.30	35x30	2.02			25x45	2.65	30x35	2.26	35x30	2.15
1200			25x50	2.88	30x40	2.55	35x30	2.22			25x60	3.19	30x40	2.53	35x35	2.48
1500					30x45	2.80	35x35	2.56					30x50	2.97	35x40	2.50
1800					30x50	3.08	35x40	2.85					30x60	3.43	35x45	3.04
2200							35x50	3.14							35x55	3.18
2700							35x60	3.49								

Cap. (μ F)	250Vdc								315Vdc							
	ϕ 22		ϕ 25		ϕ 30		ϕ 35		ϕ 22		ϕ 25		ϕ 30		ϕ 35	
150									22x25	1.00						
180									22x30	1.14						
220									22x35	1.31	25x25	1.20				
270	22x25	1.32							22x40	1.49	25x30	1.39				
330	22x30	1.54	25x25	1.45					22x45	1.69	25x35	1.59	30x25	1.41		
390	22x35	1.75	25x30	1.68					22x50	1.87	25x40	1.78	30x30	1.63	35x25	1.48
470	22x40	1.97	25x30	1.75					22x55	2.09	25x45	1.99	30x35	1.86	35x30	1.74
560	22x45	2.20	25x35	1.99	30x25	1.63			22x60	2.29	25x50	2.21	30x40	2.08	35x30	1.76
680	22x50	2.45	25x40	2.25	30x30	1.92	35x25	1.80			25x55	2.44	30x45	2.32	35x35	2.01
820	22x60	2.81	25x45	2.49	30x35	2.19	35x30	1.94			25x60	2.68	30x50	2.55	35x40	2.26
1000			25x55	2.91	30x40	2.44	35x35	2.38					30x55	2.78	35x50	2.70
1200					30x45	2.68	35x40	2.47					30x60	3.01	35x55	2.92
1500					30x55	3.15	35x45	2.92							35x60	3.12
1800							35x50	3.04								
2200							35x60	3.37								

ケースサイズ Case Size ϕ D × L(mm) \longleftarrow
 リプル電流 Ripple Current (A.r.m.s./120Hz,105°C) \longleftarrow

◆標準品一覧表 / STANDARD SIZE

Cap. (μ F)	350Vdc								385Vdc							
	ϕ 22		ϕ 25		ϕ 30		ϕ 35		ϕ 22		ϕ 25		ϕ 30		ϕ 35	
120	22x25	0.92							22x25	0.93						
150	22x30	1.08							22x30	1.08						
180	22x35	1.22	25x25	1.13					22x30	1.17	25x25	1.13				
220	22x40	1.39	25x30	1.30					22x35	1.33	25x30	1.31				
270	22x45	1.57	25x35	1.49	30x25	1.34			22x45	1.58	25x35	1.50	30x25	1.33		
330	22x50	1.77	25x40	1.69	30x30	1.56	35x25	1.42	22x50	1.78	25x40	1.70	30x30	1.55	35x25	1.40
390	22x55	1.96	25x45	1.88	30x35	1.77	35x30	1.66	22x60	2.03	25x45	1.88	30x35	1.76	35x30	1.64
470	22x60	2.17	25x50	2.09	30x40	1.99	35x35	1.90			25x55	2.18	30x40	1.97	35x35	1.87
560			25x55	2.30	30x45	2.20	35x40	2.13			25x60	2.39	30x45	2.18	35x35	1.89
680					30x50	2.43	35x40	2.17					30x50	2.40	35x40	2.12
820					30x55	2.65	35x45	2.39					30x60	2.76	35x50	2.53
1000							35x50	2.61							35x55	2.74
1200							35x60	3.01								

Cap. (μ F)	400Vdc								420Vdc							
	ϕ 22		ϕ 25		ϕ 30		ϕ 35		ϕ 22		ϕ 25		ϕ 30		ϕ 35	
100									22x25	0.85						
120	22x25	0.91							22x30	0.97						
150	22x30	1.06	25x25	1.04					22x35	1.12	25x25	1.03				
180	22x35	1.21	25x30	1.19					22x40	1.26	25x30	1.19				
220	22x40	1.37	25x30	1.28	30x25	1.25			22x45	1.43	25x35	1.36	30x25	1.23		
270	22x45	1.56	25x35	1.47	30x30	1.45			22x50	1.61	25x40	1.55	30x30	1.44	35x25	1.32
330	22x55	1.81	25x40	1.66	30x30	1.55	35x25	1.36	22x60	1.86	25x45	1.74	30x35	1.64	35x30	1.55
390			25x50	1.93	30x35	1.72	35x30	1.61			25x55	2.00	30x40	1.83	35x35	1.76
470			25x55	2.14	30x40	1.93	35x35	1.83			25x60	2.20	30x45	2.04	35x35	1.80
560					30x45	2.13	35x40	2.04					30x50	2.24	35x40	2.07
680					30x55	2.48	35x45	2.26					30x60	2.57	35x50	2.43
820							35x50	2.47							35x55	2.60
1000							35x60	2.85								

Cap. (μ F)	450Vdc								475Vdc							
	ϕ 22		ϕ 25		ϕ 30		ϕ 35		ϕ 22		ϕ 25		ϕ 30		ϕ 35	
68									22x25	0.68						
82									22x30	0.78						
100	22x25	0.85							22x35	0.90	25x25	0.85				
120	22x30	0.98	25x25	0.96					22x35	0.98	25x30	0.97				
150	22x35	1.13	25x30	1.12					22x45	1.16	25x35	1.12	30x25	1.05		
180	22x40	1.27	25x30	1.19	30x25	1.17			22x50	1.30	25x40	1.26	30x30	1.21	35x25	1.17
220	22x45	1.44	25x35	1.37	30x30	1.36	35x25	1.27	22x60	1.50	25x45	1.43	30x35	1.38	35x30	1.36
270	22x55	1.68	25x45	1.62	30x30	1.43	35x30	1.48			25x50	1.61	30x40	1.57	35x30	1.43
330			25x50	1.82	30x40	1.75	35x30	1.53			25x60	1.85	30x45	1.76	35x35	1.63
390			25x55	2.00	30x45	1.93	35x35	1.74					30x50	1.94	35x40	1.82
470					30x50	2.14	35x40	1.95					30x60	2.22	35x45	2.02
560					30x55	2.36	35x45	2.16							35x55	2.34
680							35x50	2.41								

Cap. (μ F)	500Vdc							
	ϕ 22		ϕ 25		ϕ 30		ϕ 35	
56	22x25	0.64						
68	22x30	0.73						
82	22x30	0.80	25x25	0.79				
100	22x35	0.92	25x30	0.91				
120	22x40	1.03	25x35	1.04	30x25	0.98		
150	22x50	1.22	25x40	1.19	30x30	1.14	35x25	1.11
180	22x60	1.39	25x45	1.33	30x35	1.30	35x30	1.28
220			25x50	1.50	30x40	1.47	35x30	1.35
270			25x60	1.73	30x45	1.65	35x35	1.54
330					30x55	1.91	35x40	1.74
390					30x60	2.10	35x45	1.92
470							35x55	2.23

ケースサイズ Case Size ϕ D × L (mm) \rightarrow
 リプル電流 Ripple Current (A.r.m.s./120Hz, 105°C) \rightarrow

VXK series

105°C 5000時間 超小形化品
Load Life : 105°C 5000 hours, Ultra Miniaturized



◆規格表/SPECIFICATIONS

項目 Item	特性 Characteristics							
カテゴリ温度範囲 Category Temperature Range	-25~+105°C							
定格電圧範囲 Rated Voltage Range	400~500Vdc							
静電容量許容差 Capacitance Tolerance	±20% (20°C, 120Hz)							
漏れ電流 Leakage Current (MAX)	$I=3\sqrt{CV}$ (定格電圧印加5分後) $I=3\sqrt{CV}$ (After 5 minutes application of rated voltage) I=漏れ電流 (μA) C=静電容量 (μF) V=定格電圧 (Vdc) Leakage Current Capacitance Rated Voltage							
損失角の正接 (tan δ) Dissipation Factor (MAX)	<table border="1"> <tr> <td>定格電圧 (Vdc) Rated Voltage</td> <td>400~450</td> <td>475, 500</td> <td rowspan="2">(20°C, 120Hz)</td> </tr> <tr> <td>tan δ</td> <td>0.20</td> <td>0.25</td> </tr> </table>	定格電圧 (Vdc) Rated Voltage	400~450	475, 500	(20°C, 120Hz)	tan δ	0.20	0.25
定格電圧 (Vdc) Rated Voltage	400~450	475, 500	(20°C, 120Hz)					
tan δ	0.20	0.25						
耐久性 Endurance	105°C中で5000時間定格電圧(リップル重畳)印加後、下記項目を満足すること。 After applying rated voltage with rated ripple current for 5000 hours at 105°C, the capacitors shall meet the following requirements. <table border="1"> <tr> <td>静電容量変化率 Capacitance Change</td> <td>初期値の ±20% 以内 Within ±20% of the initial value.</td> </tr> <tr> <td>損失角の正接 Dissipation Factor</td> <td>規格値の 200% 以下 Not more than 200% of the specified value.</td> </tr> <tr> <td>漏れ電流 Leakage Current</td> <td>規格値以下 Not more than the specified value.</td> </tr> </table>	静電容量変化率 Capacitance Change	初期値の ±20% 以内 Within ±20% of the initial value.	損失角の正接 Dissipation Factor	規格値の 200% 以下 Not more than 200% of the specified value.	漏れ電流 Leakage Current	規格値以下 Not more than the specified value.	
静電容量変化率 Capacitance Change	初期値の ±20% 以内 Within ±20% of the initial value.							
損失角の正接 Dissipation Factor	規格値の 200% 以下 Not more than 200% of the specified value.							
漏れ電流 Leakage Current	規格値以下 Not more than the specified value.							
低温特性 Low Temperature Stability (インピーダンス比) Impedance Ratio (MAX)	<table border="1"> <tr> <td>定格電圧 (Vdc) Rated Voltage</td> <td>400~450</td> <td>475, 500</td> <td rowspan="2">(120Hz)</td> </tr> <tr> <td>Z(-25°C)/Z(+20°C)</td> <td>8</td> <td>10</td> </tr> </table>	定格電圧 (Vdc) Rated Voltage	400~450	475, 500	(120Hz)	Z(-25°C)/Z(+20°C)	8	10
定格電圧 (Vdc) Rated Voltage	400~450	475, 500	(120Hz)					
Z(-25°C)/Z(+20°C)	8	10						

◆呼称方法/PART NUMBER

□□□
VXK
□□□□□
M
□□□
□□
D x L
 定格電圧 シリーズ名 静電容量 静電容量許容差 副記号 端子記号 ケースサイズ
 Rated Voltage Series Capacitance Capacitance Tolerance Option Terminal Code Case Size

◆リップル電流補正係数/
MULTIPLIER FOR RIPPLE CURRENT

周波数 (Hz) Frequency	60 (50)	120 (100)	300	500	1k	10k ≤
係数 Coefficient	0.80	1.00	1.15	1.20	1.25	1.40

◆副記号/OPTION

EFC : PET スリーブ、底板なし
PET Sleeve without plate

◆端子記号/Terminal Code

SN : 標準端子 Standard Terminal

その他の形状は端子形状一覧をご確認ください。
For other type, please refer to the list of terminal type.

◆寸法図/DIMENSIONS

●SN[4mm]端子タイプ
SN[4mm]terminal type

端子記号 : SN(錫メッキ)
Terminal code : SN(Tin plating)

(mm)

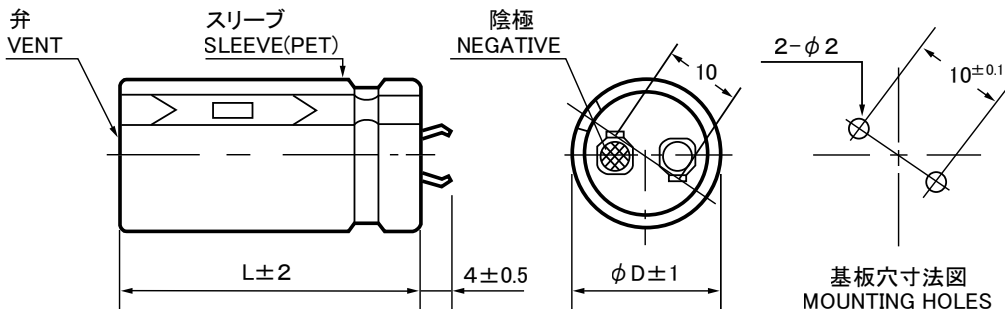

◆標準品一覧表/STANDARD SIZE

Cap. (μ F)	400Vdc								420Vdc							
	ϕ 22		ϕ 25		ϕ 30		ϕ 35		ϕ 22		ϕ 25		ϕ 30		ϕ 35	
120									22x25	0.92						
150	22x25	1.01							22x30	1.08						
180	22x30	1.17	25x25	1.13					22x30	1.16	25x25	1.12				
									22x35	1.23						
220	22x35	1.33	25x30	1.31					22x35	1.33	25x30	1.30				
									22x40	1.40						
270	22x40	1.52	25x30	1.40	30x25	1.33			22x40	1.51	25x35	1.49	30x25	1.32		
			25x35	1.50					22x45	1.58						
330	22x45	1.71	25x35	1.61	30x30	1.55			22x50	1.78	25x40	1.69	30x30	1.54	35x25	1.40
	22x50	1.78	25x40	1.70					22x55	1.96						
390	22x50	1.90	25x40	1.80	30x30	1.60	35x25	1.43	22x55	1.96	25x45	1.88	30x35	1.75	35x30	1.64
	22x55	1.97	25x45	1.89					22x60	2.02						
470	22x60	2.18	25x50	2.10	30x35	1.82	35x30	1.68			25x50	2.10	30x40	1.96	35x30	1.70
											25x55	2.17				
560			25x55	2.31	30x40	2.04	35x35	1.92			25x60	2.40	30x45	2.20	35x35	1.94
													30x50	2.29	35x40	2.07
680					30x45	2.31	35x35	2.00					30x50	2.43	35x40	2.17
					30x50	2.42	35x40	2.15					30x55	2.51	35x45	2.29
820					30x55	2.64	35x45	2.37						35x45	2.41	
														35x50	2.50	
1000							35x50	2.58							35x60	2.89
1200							35x60	2.95								

ケースサイズ Case Size ϕ D × L(mm) \longleftarrow ↑
 リプル電流 Ripple Current (A.r.m.s./120Hz,105°C) \longleftarrow ↑

◆標準品一覧表／STANDARD SIZE

Cap. (μ F)	450Vdc								475Vdc							
	ϕ 22		ϕ 25		ϕ 30		ϕ 35		ϕ 22		ϕ 25		ϕ 30		ϕ 35	
82									22x25	0.74						
100									22x30	0.84	25x25	0.85				
120	22x25	0.93							22x30	0.91	25x30	0.95				
150	22x30	1.09	25x25	1.06					22x35	1.05	25x30	1.04	30x25	1.05		
180	22x35	1.24	25x30	1.22					22x40	1.19	25x35	1.19	30x30	1.19		
220	22x40	1.41	25x30	1.31	30x25	1.26			22x45	1.34	25x40	1.35	30x30	1.28	35x25	1.22
			25x35	1.39												
270	22x45	1.59	25x35	1.50	30x30	1.46	35x25	1.35	22x55	1.56	25x45	1.52	30x35	1.47	35x30	1.43
	22x50	1.65	25x40	1.58												
330	22x55	1.85	25x45	1.78	30x30	1.55	35x25	1.41			25x50	1.71	30x40	1.66	35x30	1.50
					30x35	1.67	35x30	1.58								
390	22x60	2.03	25x50	1.97	30x35	1.75	35x30	1.61			25x60	1.95	30x40	1.75	35x35	1.70
					30x40	1.87										
470			25x55	2.18	30x40	1.97	35x35	1.84					30x50	2.04	35x40	1.90
			25x60	2.26	30x45	2.08										
560					30x50	2.29	35x40	2.06					30x60	2.33	35x45	2.11
680					30x55	2.54	35x45	2.28							35x55	2.45
					30x60	2.63										
820							35x50	2.55								
1000							35x60	2.93								

Cap. (μ F)	500Vdc							
	ϕ 22		ϕ 25		ϕ 30		ϕ 35	
68	22x25	0.69						
82	22x30	0.77						
100	22x30	0.85						
120	22x35	0.96	25x30	0.96				
150	22x40	1.11	25x30	1.06				
180	22x45	1.25	25x35	1.20	30x30	1.20	35x25	1.16
220	22x50	1.40	25x40	1.36	30x30	1.29	35x30	1.35
270	22x60	1.62	25x50	1.60	30x35	1.48	35x30	1.43
330			25x55	1.78	30x40	1.67	35x35	1.63
390					30x45	1.85	35x40	1.82
470					30x55	2.14	35x45	2.02
560					30x60	2.34	35x50	2.23
680							35x55	2.44

ケースサイズ Case Size ϕ D × L(mm) \longleftarrow ↑
 リプル電流 Ripple Current (A.r.m.s./120Hz, 105°C) \longleftarrow ↑

VXT series

105°C 5000時間 超小形化品
Load Life : 105°C 5000 hours, Ultra Miniaturized



◆規格表/SPECIFICATIONS

項目 Item	特性 Characteristics																
カテゴリ温度範囲 Category Temperature Range	-25~+105°C																
定格電圧範囲 Rated Voltage Range	400~500Vdc																
静電容量許容差 Capacitance Tolerance	±20%(20°C, 120Hz)																
漏れ電流 Leakage Current (MAX)	$I=3\sqrt{CV}$ (定格電圧印加5分後) $I=3\sqrt{CV}$ (After 5 minutes application of rated voltage) I=漏れ電流(μA) C=静電容量(μF) V=定格電圧(Vdc) Leakage Current Capacitance Rated Voltage																
損失角の正接(tan δ) Dissipation Factor (MAX)	<table border="1"> <tr> <td>定格電圧 (Vdc) Rated Voltage</td> <td>400~450</td> <td>475, 500</td> <td rowspan="2">(20°C, 120Hz)</td> </tr> <tr> <td>tan δ</td> <td>0.20</td> <td>0.25</td> </tr> </table>	定格電圧 (Vdc) Rated Voltage	400~450	475, 500	(20°C, 120Hz)	tan δ	0.20	0.25									
定格電圧 (Vdc) Rated Voltage	400~450	475, 500	(20°C, 120Hz)														
tan δ	0.20	0.25															
耐久性 Endurance	105°C中で5000時間定格電圧(リップル重畳)印加後、下記項目を満足すること。 After applying rated voltage with rated ripple current for 5000 hours at 105°C, the capacitors shall meet the following requirements.																
低温特性 Low Temperature Stability (インピーダンス比) Impedance Ratio (MAX)	<table border="1"> <tr> <td>静電容量変化率 Capacitance Change</td> <td colspan="2">初期値の ±20% 以内 Within ±20% of the initial value.</td> </tr> <tr> <td>損失角の正接 Dissipation Factor</td> <td colspan="2">規格値の 200% 以下 Not more than 200% of the specified value.</td> </tr> <tr> <td>漏れ電流 Leakage Current</td> <td colspan="2">規格値以下 Not more than the specified value.</td> </tr> </table> <table border="1"> <tr> <td>定格電圧 (Vdc) Rated Voltage</td> <td>400~450</td> <td>475, 500</td> <td rowspan="2">(120Hz)</td> </tr> <tr> <td>Z(-25°C)/Z(+20°C)</td> <td>8</td> <td>10</td> </tr> </table>	静電容量変化率 Capacitance Change	初期値の ±20% 以内 Within ±20% of the initial value.		損失角の正接 Dissipation Factor	規格値の 200% 以下 Not more than 200% of the specified value.		漏れ電流 Leakage Current	規格値以下 Not more than the specified value.		定格電圧 (Vdc) Rated Voltage	400~450	475, 500	(120Hz)	Z(-25°C)/Z(+20°C)	8	10
静電容量変化率 Capacitance Change	初期値の ±20% 以内 Within ±20% of the initial value.																
損失角の正接 Dissipation Factor	規格値の 200% 以下 Not more than 200% of the specified value.																
漏れ電流 Leakage Current	規格値以下 Not more than the specified value.																
定格電圧 (Vdc) Rated Voltage	400~450	475, 500	(120Hz)														
Z(-25°C)/Z(+20°C)	8	10															

◆呼称方法/PART NUMBER

□□□
VXT
□□□□□
M
□□□
□□
D x L
 定格電圧 シリーズ名 静電容量 静電容量許容差 副記号 端子記号 ケースサイズ
 Rated Voltage Series Capacitance Capacitance Tolerance Option Terminal Code Case Size

◆リップル電流補正係数/
MULTIPLIER FOR RIPPLE CURRENT

周波数 (Hz) Frequency	60 (50)	120 (100)	300	500	1k	10k ≤
係数 Coefficient	0.80	1.00	1.15	1.20	1.25	1.40

◆副記号/OPTION

EFC : PET スリーブ、底板なし
PET Sleeve without plate

◆端子記号/Terminal Code

SN : 標準端子 Standard Terminal

その他の形状は端子形状一覧をご確認ください。
For other type, please refer to the list of terminal type.

◆寸法図/DIMENSIONS

●SN[4mm]端子タイプ
SN[4mm]terminal type

端子記号 : SN(錫メッキ)
Terminal code : SN(Tin plating)

(mm)

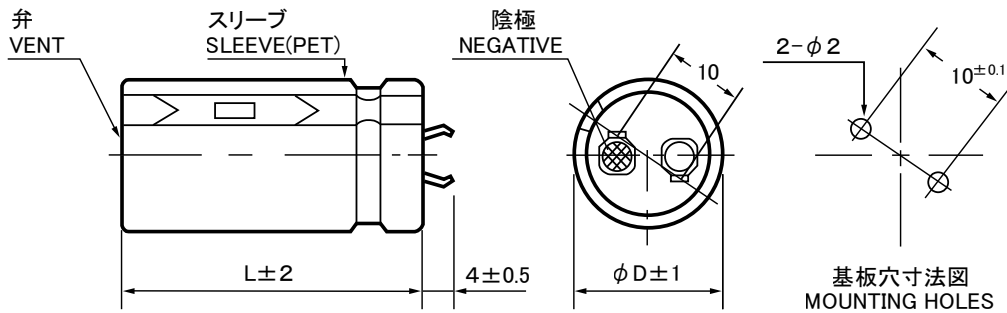

◆標準品一覧表/STANDARD SIZE

Cap. (μ F)	400Vdc								420Vdc							
	ϕ 22		ϕ 25		ϕ 30		ϕ 35		ϕ 22		ϕ 25		ϕ 30		ϕ 35	
150	22x25	0.99							22x25	0.96						
180	22x30	1.14							22x30	1.12	25x25	1.08				
220	22x30	1.22	25x25	1.18					22x35	1.28	25x30	1.24				
270	22x35	1.41	25x30	1.39					22x40	1.47	25x30	1.33	30x25	1.29		
330	22x40	1.60	25x35	1.60	30x25	1.37			22x45	1.66	25x35	1.53	30x30	1.47		
390	22x45	1.78	25x40	1.79	30x30	1.61	35x25	1.45	22x50	1.82	25x40	1.72	30x30	1.56	35x25	1.40
470	22x55	2.09	25x45	2.01	30x35	1.85	35x30	1.65	22x60	2.12	25x45	1.93	30x35	1.79	35x30	1.66
560			25x50	2.21	30x40	2.08	35x30	1.73			25x55	2.26	30x40	2.01	35x35	1.87
680			25x60	2.56	30x45	2.31	35x35	1.99			25x60	2.45	30x45	2.23	35x35	1.92
820					30x50	2.54	35x40	2.22					30x50	2.47	35x40	2.20
1000					30x55	2.80	35x45	2.51					30x60	2.84	35x50	2.58
1200							35x55	2.88							35x55	2.85

Cap. (μ F)	450Vdc								475Vdc							
	ϕ 22		ϕ 25		ϕ 30		ϕ 35		ϕ 22		ϕ 25		ϕ 30		ϕ 35	
100									22x25	0.81						
120	22x25	0.89							22x30	0.94						
150	22x30	1.04							22x30	1.02	25x25	1.00				
180	22x30	1.11	25x25	1.08					22x35	1.18	25x30	1.16				
220	22x35	1.29	25x30	1.26					22x40	1.33	25x35	1.33	30x25	1.22		
270	22x40	1.45	25x35	1.45	30x25	1.28			22x50	1.58	25x40	1.52	30x30	1.42	35x25	1.33
330	22x50	1.74	25x40	1.65	30x30	1.51	35x25	1.37	22x55	1.75	25x45	1.72	30x35	1.63	35x30	1.57
390	22x55	1.91	25x45	1.84	30x35	1.72	35x30	1.56			25x50	1.88	30x40	1.83	35x30	1.61
470			25x50	2.03	30x40	1.91	35x30	1.64			25x60	2.19	30x45	2.04	35x35	1.84
560			25x55	2.22	30x40	2.00	35x35	1.88					30x50	2.26	35x40	2.07
680					30x50	2.36	35x40	2.11					30x60	2.60	35x45	2.29
820					30x55	2.59	35x45	2.32							35x55	2.67
1000							35x55	2.72								

Cap. (μ F)	500Vdc							
	ϕ 22		ϕ 25		ϕ 30		ϕ 35	
100	22x25	0.82						
120	22x30	0.94						
150	22x35	1.10	25x25	0.99				
180	22x35	1.16	25x30	1.16				
220	22x45	1.41	25x35	1.34	30x25	1.21		
270	22x50	1.59	25x40	1.53	30x30	1.42	35x25	1.33
330	22x60	1.84	25x45	1.70	30x35	1.63	35x30	1.57
390			25x55	1.98	30x40	1.83	35x30	1.59
470			25x60	2.16	30x50	2.15	35x40	1.99
560					30x55	2.36	35x45	2.21
680							35x50	2.43
820							35x60	2.80

ケースサイズ Case Size $\phi D \times L$ (mm) \rightarrow
リップル電流 Ripple Current (A.r.m.s./120Hz,105°C) \rightarrow

当社では、旧シリーズの生産終息を計画的に進めております。旧シリーズに対して代替シリーズをご用意しており、サイズメリット、コストメリットのある製品をご提案いたします。

Production discontinuation of old series at Rubycon is implemented as planned. Technical documents and samples are available upon the request to study alternative products.

◆CHIP ALUMINUM ELECTROLYTIC CAPACITORS

製品の特長 FEATURES	旧シリーズ PREVIOUS SERIES	廃止対象品 DISCONTINUED ITEMS	最終受注期日 FINAL ACCEPTED ORDER DATE	代替シリーズ SUBSTITUTE SERIES
GENERAL PURPOSE	SEV, SKV, JEV, JKV, JGV	φ4×L5.5, φ5×L5.5, φ6.3×L5.5, φ4×L6.1, φ5×L6.1, φ6.3×L6.1 φ8×L6.5	2024.12	JZV, TZV, TRV
LOW IMPEDANCE	SZV			
LONG LIFE	JGV, SGV, SJV, SLV			
BI-POLAR	NSEV, NSKV, NSGV			

◆RADIAL LEAD ALUMINUM ELECTROLYTIC CAPACITORS

製品の特長 FEATURES	旧シリーズ PREVIOUS SERIES	廃止対象品 DISCONTINUED ITEMS	最終受注期日 FINAL ACCEPTED ORDER DATE	代替シリーズ SUBSTITUTE SERIES
GENERAL PURPOSE	MS5, MH5, MS7, MH7 ML	ALL SERIES	2024.12	-
LOW LEAKAGE CURRENT	TWL	φ4×L5, φ5×L5, φ6.3×L5, φ8×L5, φ4×L7, φ5×L7, φ6.3×L7, φ8×L7, φ8×L7.5		
FOR CHARGER	AX			
LOW IMPEDANCE	ZL, ZLG, ZLH, YXG			
BI-POLAR	NA	ALL SERIES	2023.12	NXA
	NW5, NW7	ALL SERIES	2023.12	-
GENERAL PURPOSE	YK	ALL SERIES	2012.09	PK
	YXA	ALL SERIES	2012.09	PX
	WA	ALL SERIES	2023.12	WXA
LOW IMPEDANCE	ZA	ALL SERIES	2008.09	ZLG,ZLQ
	ZL, YXF, YXG, YXH	63WV OR MORE	2023.12	YXJ, ZLJ, ZLH
	YXF	160WV OR MORE	2023.12	CFX
	ZT	ALL SERIES	2024.12	-
LONG LIFE	BXA	ALL SERIES	2013.09	BXG
	BXF	ALL SERIES	2023.12	BXG,BXW
	CGX	ALL SERIES	2023.12	LLE
FOR POWER SUPPLY	MXW(VSL)	ALL SERIES	2002.09	QXW
	AXW	ALL SERIES	2010.09	
	VXW	ALL SERIES	2010.09	BXW
	KXW	ALL SERIES	2024.12	QXW,HXW
	TXW	160WV OR MORE	2024.12	BXW,LXW
	SXW	φ12.5 OR MORE	2024.12	SAW,SBW
LOW IMPEDANCE	YXJ	2.2μF OR LESS CAPACITANCE	2026.07	-
HIGH TEMPERATURE	RX30	10μF OR LESS CAPACITANCE		

◆SNAP-IN / SCREW TERMINAL ALUMINUM ELECTROLYTIC CAPACITORS

製品の特長 FEATURES	旧シリーズ PREVIOUS SERIES	廃止対象品 DISCONTINUED ITEMS	最終受注期日 FINAL ACCEPTED ORDER DATE	代替シリーズ SUBSTITUTE SERIES
105°C STANDARD	MXP	ALL SERIES	1998.09	MXG
	MXR	ALL SERIES	2007.09	
105°C LONG LIFE	VXP	ALL SERIES	2008.09	VXG
105°C 20mm HEIGHT	MXF	ALL SERIES	2003.09	KXF
	AXF	ALL SERIES	2012.09	
OVER-VOLTAGE VENTING SPECIFICATION	SXR	ALL SERIES	2012.09	SXG
FOR STROBE FLASH	CDF, FKX	ALL SERIES	2021.01	-
SCREW TERMINAL TYPE	LSQ, LSU, LSY, LSA, LUR LSW, LSG, LSH, LSC, LHR	ALL SERIES	2022.12	-

Rubycon



ルビコン株式会社

RUBYCON CORPORATION

URL <https://www.rubycon.co.jp>

ルビコン株式会社 本社

〒396-8593 長野県伊那市西箕輪1938-1
TEL: 0265-72-7111 FAX: 0265-73-2914

営業本部

〒396-8593 長野県伊那市西箕輪1938-1
TEL: 0265-72-7114 FAX: 0265-76-5282

国内営業部・東京支店

〒171-0022 東京都豊島区南池袋2-30-8 友泉南池袋ビル4階
TEL: 03-5396-5001 FAX: 03-5396-1190

水戸営業所

〒312-0018 茨城県ひたちなか市笹野町2-12-2 マリンコート 1202号室
TEL: 029-275-6531 FAX: 029-275-6458

海外営業部

〒171-0022 東京都豊島区南池袋2-30-8 友泉南池袋ビル5階
TEL: 03-5396-3738 FAX: 03-5391-2466

Rubycon Hong Kong Ltd.

Unit 03&05, 30F Laws Commercial Plaza, 788 Cheung Sha Wan Road,
Kowloon, Hong Kong
TEL: +852-2710-8875 FAX: +852-2332-9237

Rubycon International (Shanghai) Co., Ltd.

Rm 1307, New Town Center, No. 83 Lou Shan Guan Road, Shanghai,
China
TEL: +86-21-6236-9786 FAX: +86-21-6236-8266

Rubycon International (Shanghai) Co., Ltd.

Chongqing Liaison Office

Room 09, Floor 18, Block A, Shinkansen Building, No.55, Chongqing Village,
Yuzhong District, Chongqing, China

Rubycon Corporation Taiwan Branch

Room 2, 13F, No.318, Songjiang Road, Zhongshan District, Taipei City,
10468 R.O.C
TEL: +886-2-2581-6068 FAX: +886-2-2581-5068

Rubycon Corporation Branch Netherlands

De Fruittuinen 18, 2132 NZ Hoofddorp, The Netherlands
TEL: +31-23-554-3510

Rubycon Corporation Branch Munich

Stefan-George-Ring 2, 81929 Munich, Germany
TEL: +49-89-930-86250

Rubycon America Inc.

4293 Lee Avenue, Gurnee, IL60031, USA
TEL: +1-847-249-3450 FAX: +1-847-578-1300

大阪支店

〒538-0053 大阪府大阪市鶴見区鶴見4-14-52
TEL: 06-6913-0141 FAX: 06-6913-0145

名古屋支店

〒463-0072 愛知県名古屋守山区金屋1-12-19
TEL: 052-793-1210 FAX: 052-791-1481

長野営業所

〒396-8593 長野県伊那市西箕輪1938-1
TEL: 0265-73-6141 FAX: 0265-76-5282

広島営業所

〒730-0017 広島県広島市中区鉄砲町1-20 第3ウエノヤビル 3階
TEL: 082-222-3858 FAX: 082-222-6585

Rubycon Singapore Pte. Ltd.

2 Jurong East Street 21, IMM Building #05-36, Singapore 609601
TEL: +65-6472-2466 FAX: +65-6479-0241

Rubycon India Pvt. Ltd.

Lorven Coworks, No.756, 2nd Floor, 10th Main Road, Jayanagar 4th Block,
Bengaluru, 560041 India
TEL: +91-22-40069237

Rubycon India Pvt. Ltd. Delhi Branch

ConnectHQ workspaces, Third Floor, Plot Number F2, Sector8,
Noida 201301, Uttar Pradesh, India
TEL: +91-81-78986101

Rubycon India Pvt. Ltd. Mumbai Branch

A503 Dimple Arcade Annex, Thakur-East, Mumbai 400101,
Maharashtra, India
TEL: +91-22-40069237

Rubycon International (Thailand) Co., Ltd.

11F, Sitthivorakit Bld., 5 Soi Pipat, Silom Road, Bangkok 10500, Thailand
TEL: +66-2-266-8359 FAX: +66-2-266-8360

Rubycon Korea Co., Ltd.

Leaders Tower 301, #60-15 Kasan-Dong, Kumcheon-ku, Seoul, Korea
TEL: +82-2-855-8127 FAX: +82-2-855-8128



安全に関するご注意
CAUTION FOR SAFETY

- ・製品を正しく安全にお使いいただくため、ご使用前に必ず「使用上の注意事項」をよくお読み下さい。
- ・ご注文の際は当社に「納入仕様書」をご要求いただくと共に、当社仕様書の記載内容を逸脱して当品をご使用にならないでください。また、仕様書は部品単体での品質を保証するものですので、ご使用の際は貴社製品に実装された状態で必ず評価・確認を行ってください。
- ・当社カタログに記載の製品は、一般電子機器に標準的な用途で使用されることを意図しています。従いまして、製品の事故や誤動作が人命又は財産に危害を及ぼす恐れがある等の理由により、より高度な安全性・信頼性が求められる機器(交通・輸送機器、医療機器、航空・宇宙機器、発電所制御用機器など)にご使用を検討される場合は、当製品の適合性について必ず事前に当社にご相談・ご確認ください。

- ・ Please be sure to read through the "CAUTION FOR PROPER USE" for safe and appropriate use of our product in advance of use.
- ・ You can request that we submit a "SPECIFICATION SHEET" when or before an order is placed. You may not use the product for any purpose other than the ones specified in our specification sheet. Since the specification sheet is to assure the quality of the component, please be sure to evaluate and confirm performance within your application before use.
- ・ The products listed in our catalog are intended for standard applications in general electronic equipment. Accordingly, please be sure to consult us to if you have special use condition or an application that may require greater safety or reliability to protect human life and property. Applications such as transportation, medical, aerospace, power station control are some of the examples of such applications.